

SERIE EKU₅₃

prodotti e sistemi brevettati
per la costruzione di serramenti a battente



GRUPPO
PROFILATI

DESCRIZIONE TECNICA DEL SISTEMA "EKU" PER FINESTRE E PORTE A BATTENTE TECHNICAL DESCRIPTION OF THE "EKU" SYSTEM FOR WINDOWS AND DOORS



Profilati estrusi in lega di alluminio EN AW-6060 (UNI EN 573/3)

Stato di fornitura: T 5

Tolleranze dimensionali e spessori: UNI EN 12020-2

Lunghezza commerciale barre profilati: mm. 6500

Caratteristiche principali del Sistema:

Dimensione base:	EKU53
- sezione del telaio fisso	mm. 45
- sezione dell' anta	mm. 53
- sezione dell' anta per porte	mm. 45
- sovrapposizione a muro dei telai fissi	mm. 22
- altezza sede vetro	mm. 22
- larghezza massima per vetro o pannello	mm. 32

inserimento del vetro con fermavetro a scatto o ad aggancio con clips secondo il tipo di fermavetro scelto;

sedi alloggiamento accessori: a dimensioni standard secondo camera europea mm. 14-18;

tenuta aria/acqua ottenuta tramite guarnizione centrale a giunto aperto, con guarnizione di battuta parapolvere e antirumore inserita nella cava sull'alletta interna dell' anta;

nelle porte la tenuta è prevista con doppia guarnizione di battuta;

Possibilità di impiego: i sistemi consentono la costruzione di serramenti a superfici piane, complanari sul lato esterno e sormonto interno, con alletta di vetratura arrotondata; si possono fabbricare porte e finestre a battente, con apertura ad una o più ante, a wasistas, ad anta ribalta, vetrate fisse, vetrine per negozi, portoncini con apertura verso l'interno e/o l'esterno: questi ultimi sono a superficie complanare esterno/interno.

NOTE TECNICHE

Il peso dei profilati e quello teorico e potrà variare in funzione delle tolleranze dimensionali e di spessore previste dalla norma UNI EN 12020-2; le dimensioni di taglio indicate nelle apposite distinte sono calcolate in base alle dimensioni nominali: nella pratica potranno essere influenzate dalle tolleranze di estrusione, pertanto dovranno essere arrotondate secondo la precisione ed il tipo di impostazione delle misure nelle macchine impiegate. Gli schemi, le sezioni e gli attacchi al muro riportati sul catalogo, non hanno valore limitativo, ma solo di esemplificazione di alcune delle situazioni che più comunemente si trovano nella realtà e di soluzione consigliabile; la posa del serramento va eseguita rispettando la normativa, le prescrizioni e le raccomandazioni specifiche esistenti.

Il sistema di profilati riportato in questo catalogo è brevettato; tutti i dati riportati nel presente catalogo sono indicativi e non impegnano la Profilati spa e la Trafilerie Emiliane Sud S.p.A. che si riservano di apportare in qualsiasi momento

quelle modifiche che riterranno opportune al fine di migliorare i prodotti. Quanto illustrato nel presente catalogo è di esclusiva proprietà Profilati spa e, a termine di legge ne è vietata la riproduzione, anche parziale, se non esplicitamente autorizzata.

Profilati spa

Aluminium alloy EN AW-6060 (UNI EN 573/3) extruded sections

Temper : T5

Dimensional tolerances and thicknesses: UNI EN 12020-2

Commercial length of the bars: 6500 mm

Main Characteristics of the System:

Basic Dimensions:	EKU53
- Fixed frame cross-section:	mm 45
- Wing cross-section:	mm 53
- Wing cross-section for doors:	mm 45
- Fin of rabbet for fixed frames:	mm 22
- Glass seat space:	mm 22
- Maximum width for glass or panel:	mm 32

Glass insertion with snap or clip connection glazing bead according to the type of glazing bead chosen;

Accessory housing seats: standard dimensions according to the 14-18mm European air space;

Sealing obtained through central open joint gasket with weather strip inserted in the slot on the internal fin of the wing;

Door seal is ensured through double weatherstrip;

Application: The systems allow for construction of plane surface fixtures, coplanar on the external side and internal overlap, with rounded glass beading. It is possible to manufacture doors and casement, or top-hung, one or more wing opening windows, fixed glazing panels, shop-windows, internal and/or external opening doors. The latter have an external/internal coplanar surface.

TECHNICAL NOTES

The weight of the sections is the theoretical and can vary according to the dimensional and thickness tolerances specified by UNI EN 12020-2 Standard. The cutting dimensions indicated in the appropriate forms are calculated on the basis of the nominal size. In practice these dimensions can be affected by extrusion tolerances; therefore they shall be rounded according to accuracy and type of measures set in the machines used. Diagrams, sections and wall connections show some of the catalogue are an indication and not a limitation; they simply show some of the situations which are most commonly found in practice and recommended solutions. Fixture mounting shall be in compliance with standards, requirements and specific recommendations existing in Italy.

The system of sections shown in this catalogue is patented; all data given in this catalogue are an indication and do not bind Profilati S.p.A. and Trafilerie Emiliane Sud S.p.A. which reserve the right to make any modifications deemed appropriate to improve products.

All that is show in this catalogue is property of Profilati S.p.A. Any reproduction, even if partial, is forbidden by law unless expressly authorized.

Profilati S.p.A.

Caratteristiche meccaniche e fisiche - Typical mechanical and physical properties

Leghe in alluminio da bonifica - Estrusi - Heat treatable aluminium alloys - Extrusions

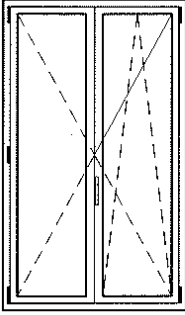
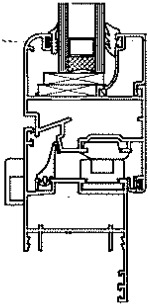

LEGA	STATO UNI EN 575	SPESSORE THICKNESS mm	CARATTERISTICHE MECCANICHE TYPICAL MECHANICAL PROPERTIES			CARATTERISTICHE FISICHE TYPICAL PHYSICAL PROPERTIES				
			Carico di rottura a frazione N/mm ²	Carico al limite di snervamento N/mm ²	Allungam. A %	Composiz. chimica nominale %	Peso specifico Kg/dm ³	Conduttività termica (W/mk)	Resistività elettrica (nohmm)	Coefficiente di dilataz. termica lineare/µm/m/K
ALLOY	TEMPER	mm	Ultimate Strength N/mm ²	Yield Strength N/mm ²	Elongation A %	Nominal chemical compos. %	Specific gravity Kg/dm ³	Thermal conductivity (W/mk)	Electrical resistivity (nohmm)	Average coeff. thermal exp µm/m/K
EN	T5	≤5	160	120	8	Mg 0,35-0,60	2,70	209	26,55	23,4
AW-6060	T6	≤3	190	150	8	Si 0,30-0,60		209	26,55	

SISTEMA SYSTEM	TIPOLOGIA WINDOWS AND DOOR	DIMENSIONI DIMENSIONS LXH mm	RISULTATI PROVE TEST VALUES			SEZIONI CROSS SECTIONS	CERTIFICATO N° CERTIFICATE N°
			Aria Air	Acqua Water	Vento Wind		
EKU 53		1400 x 2300	A4	9A	B3		199334 del 19/07/05

CAMPO D'IMPIEGO PROFILI - RANGE OF USE FOR PROFILES

N° profilo anta N° profile wing	Per altezza edificio 0-20 mt For height building				Per altezza edificio 20-100 mt For height building			
	Larghezza anta max. (mm) Width wing max.	Altezza anta max. (mm) Height wing max.	Una chiusura suppl. oltre (La-Ha) One addit. lock	Due chiusure suppl. oltre (La-Ha) Two addit. locks	Larghezza anta max. (mm) Width wing max.	Altezza anta max. (mm) Height wing max.	Una chiusura suppl. oltre (La-Ha) One addit. lock	Due chiusure suppl. oltre (La-Ha) Two addit. locks
Finestra ad un'anta e/o anta ribalta One wing casement window or combined bottom and tilt-turn window								
4265	1000	1400	1000	-	900	1300	900	-
4273	1300	1600	1100	1600	1100	1500	1000	1500
Portabalcone ad un'anta e/o anta ribalta Balcony door one wing or combined bottom and tilt-turn door								
4265	900	2100	1000	1600	800	2000	900	1500
4273	1000	2200	1100	1700	900	2100	1000	1600
Finestra due ante - Two wings casement window								
4265	1000	1400	1000	-	900	1300	900	-
4273	1100	1600	1100	-	1000	1500	1000	-
Portabalcone due ante - Two wings balcony door								
4265	600	2100	1000	1600	500	2000	900	1500
4273	700	2200	1100	1700	600	2100	1000	1600



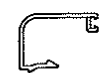
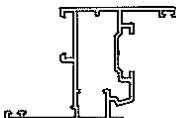
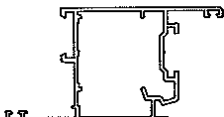
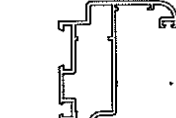
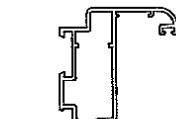
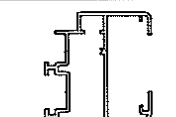
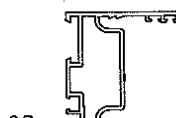
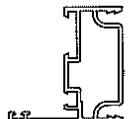
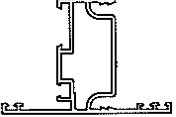
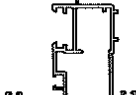
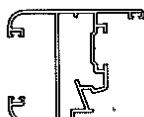

N.B. Dimensione minima anta La = 400 - Ha = 500 mm - Peso max. anta = kg120 - Minimum wing sizes La = 400 - Ha = 500 mm - Max wing weight = kg. 120

Codice Code	Sagoma Shape	Kg/mt.	Descrizione Description	sup. vista mm	Jx cm ⁴	Perim. mm
4195		0.292	Fermavetro arrotondato a scatto (L = 23) <i>Snap type rounded glass beading</i>	41	-	176
4196		0.319	Fermavetro arrotondato a scatto (L = 31) <i>Snap type rounded glass beading</i>	49	-	187
4197		0.297	Fermavetro arrotondato a clips (L = 31) <i>Rounded glass beading fixed with clips</i>	48	-	148
4198		0.926	Anta a doppia guarnizione di battuta <i>Double rabbet</i>	101	9.88	325
4199		1.098	Anta maggiorato a doppia guarnizione di battuta <i>Double oversize rabbet</i>	136	12.6	360
4200*		1.005	Telaio fisso "Z" complanare <i>Coplanar Z-fixed frame</i>	113	-	360
4201*		1.110	Telaio fisso "L" complanare <i>Coplanar L-fixed frame</i>	140	-	412
4202		1.072	Anta persiana Kikau versione complanare <i>Coplanar version, Kikau shutter wing</i>	140	14.68	389
4260*		0.920	Telaio fisso "Z" <i>Z-fixed frame</i>	98	-	340
4261*		0.795	Telaio fisso "L" <i>L-fixed frame</i>	72	-	276
4262*		0.920	Telaio fisso "T" <i>T-fixed frame</i>	98	-	341
4263		0.885	Battuta centrale <i>Central rabbet</i>	68	-	313
4264		1.114	Anta vetro infilare <i>For wing with glass to be inserted</i>	127	15,3	397

Note:  = Profili po narudžbi

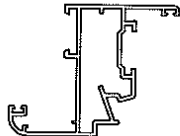
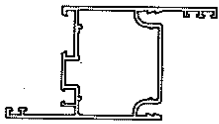
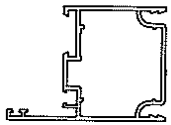
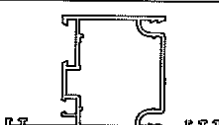
 = Profili na stanju u Sarajevu

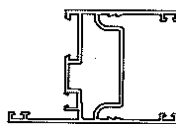
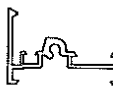
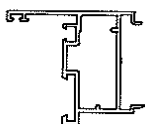
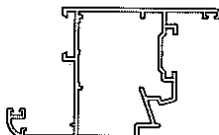
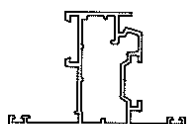
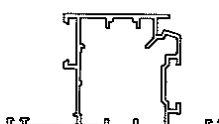
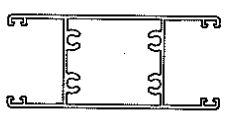



* Ostali profili su na redovnom lageru u Bolonji

Codice Code	Sagoma Shape	Kg/mt.	Descrizione Description	sup. vista mm	Jx cm ⁴	Perim. mm
4265		1.050	Anta For wing	112	14.3	363
4266*		1.088	Telaio fisso "Z" maggiorato Oversize Z-fixed frame	133	-	377
4267*		0.964	Telaio fisso "L" maggiorato Oversize L-fixed frame	108	-	312
4268*		1.088	Telaio fisso "T" maggiorato Oversize T-fixed frame	133	-	377
4269		0.265	Copertina scatto telaio fisso Cover joint for fixed frame	53	-	144
4270		1.021	"L" soglia "L" threshold	125	-	390
4271		0.553	Soglia ridotta Small threshold	43	-	239
4272		0.781	Inversione battuta sporgere Inversion of rabbet for projecting window	62	-	282
4273		1.215	Anta maggiorata For oversize wing	138	17.98	398
4274		0.955	Anta apertura esterna External opening wing	104	9.75	330
4275		1.135	Anta apertura esterna maggiorata External opening oversize wing	136	12.8	360
4276		1.224	Fascia da 84 mm vetro infilare Horizontal transom for glass to be inserted	185	9.7	380
4277		1.616	Fascia da 128 mm vetro infilare Horizontal transom for glass to be inserted	272	14.09	468

Note:  = Profili po narudžbi

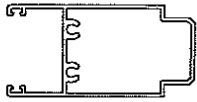
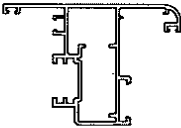
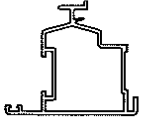
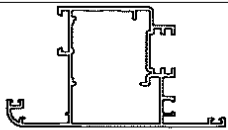
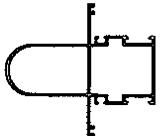
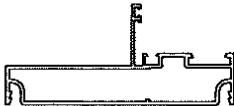
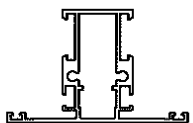
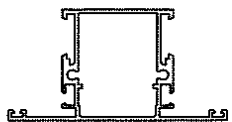
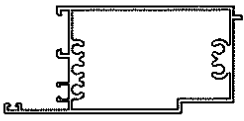
 = Profili na stanju u Sarajevu

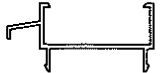











* Ostali profili su na redovnom lageru u Bolonji

Codice Code	Sagoma Shape	Kg/mt.	Descrizione Description	sup. vista mm	Jx cm ⁴	Perim. mm
4278		0.985	Zoccolo vetro infilare <i>Lower additional transom for glass to be inserted</i>	130	7.53	288
4279		1.185	Anta per bilico <i>For wing of pivoting window</i>	130	14.9	417
4280		0.875	Inversione battuta per bilico <i>Inversion of rabbet for pivoting window</i>	74	8.87	283
4281		1.353	Anta per bilico (maggiorato) <i>For oversize wing of pivoting window</i>	166	19.4	452
4282		1.631	Pilastrino arrotondato da 100 mm <i>100 mm rounded mullion</i>	238	52.5	473
4283		1.300	Mezzo pilastrino <i>Half mullion</i>	123	45.1	385
4284		1.102	"T" da 72 mm <i>T-Profile 72 mm.</i>	110	9.47	359
4285		1.204	"T" da 89 mm <i>T-Profile 89 mm.</i>	150	11.85	393
4286		1.463	Zoccolo riportato <i>Lower additional transom</i>	153	14.55	330
4287		2.052	Fascia da 160 mm <i>Horizontal transom for door 160 mm.</i>	285	23.38	535
4288		2.149	Zoccolo da 160 mm <i>Lower transom for door 160 mm.</i>	302	25.62	563
4289		0.465	Vaschetta raccoglicondensa <i>For condensation collection</i>	41	-	236
4290		0.224	Fermavetro arrotondato a clips (L = 13) <i>Rounded glass beading fixed with clips</i>	30	-	112

Note:  = Profili po narudžbi

 = Profili na stanju u Sarajevu

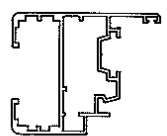
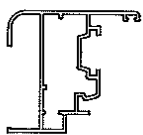

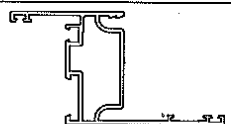



* Ostali profili su na redovnom lageru u Bolonji

Codice Code	Sagoma Shape	Kg/mt.	Descrizione Description	sup. vista mm	Jx cm ⁴	Perim. mm
4291		0.240	Fermavetro arrotondato a clips (L = 17) <i>Rounded glass beading fixed with clips</i>	34	-	120
4292		0.264	Fermavetro arrotondato a clips (L = 23) <i>Rounded glass beading fixed with clips</i>	40	-	132
4293		0.183	Fermapannello (L = 4) <i>Glass beading for panels</i>	26	-	102
4294		0.254	Fermavetro a scatto (L = 13) <i>Snap coupled glass beading</i>	35	-	150
4295		0.243	Fermavetro arrotondato a scatto (L = 13) <i>Snap type rounded glass beading</i>	30	-	145
4296		0.265	Fermavetro a scatto (L = 17) <i>Snap coupled glass beading</i>	39	-	158
4297		0.329	Fermavetro a scatto (L = 31) <i>Snap coupled glass beading</i>	53	-	192
4298		0.305	Fermavetro a scatto (L = 23) <i>Snap coupled glass beading</i>	45	-	181
4299		0.254	Fermavetro arrotondato a scatto (L = 17) <i>Snap type rounded glass beading</i>	35	-	153
5633		0.165	Battuta riportata porte <i>Additional rabbet for door</i>	50	-	93
5679		1.230	Anta persiana Metaltecnica <i>Metaltecnica shutter wing</i>	152	17.8	401
5680		0.945	Anta persiana Teknalsystems-Naco <i>Teknalsystem-Naco shutter wing</i>	115	12.4	332
5681		1.284	Fascia/zoccolo persiana Teknalsystems-Naco <i>Central or lower horizontal transom for Teknalsystem-Naco</i>	208	-	365
5682		1.011	Telaio fisso battuta 40 mm <i>Z-fixed frame with oversize rabbet fin</i>	118	-	375

Note:  = Profili po narudžbi

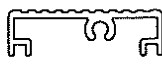
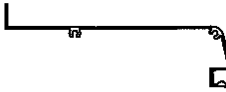
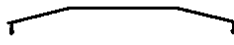
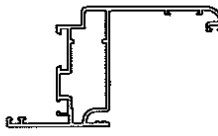
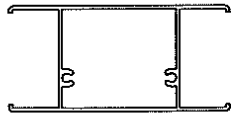
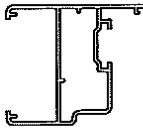
 = Profili na stanju u Sarajevu

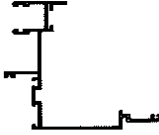
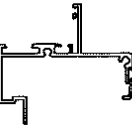
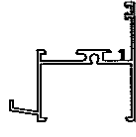





* Ostali profili su na redovnom lageru u Bolonji

Codice Code	Sagoma Shape	Kg/mt.	Descrizione Description	sup. vista mm	Jx cm ⁴	Perim. mm
5683		0.297	Riduzione per vetro semplice <i>Reducer for simple glass (for 4264)</i>	17	-	182
5767		0.190	Gocciolatoio <i>Water drainage</i>	23	-	75
6005		0.218	Profilato per giunti a nastro <i>Joint sections for frame expansion</i>	19	-	112
6009		0.405	Soglia porte <i>Door threshold</i>	66	-	175
6013		1.183	Cassonetto (superiore ed inferiore) <i>Shutter box (upper and lower profile)</i>	202	-	513
6014		1.019	Cassonetto (profilo centrale) <i>Shutter box (central profile)</i>	217	-	478
6015		1.129	Telaio fisso battuta 50 mm arr. <i>Z-Fixed frame with oversize rabbet fin</i>	110	-	414
6018		1.296	Zoccolino/fascioncino porte interne <i>Central or lower horizontal transom for internal doors</i>	203	-	383
6019		0.994	Anta per porte interne <i>Of wing for internal doors</i>	127	14.9	341
6020		0.421	Riduzione per vetro semplice <i>Reducer for simple glass (for 6019)</i>	26	-	259
6021		1.570	Spalla monoblocco <i>Monoblock frame</i>	206	-	743
6022		0.960	Traverso superiore monoblocco <i>Monoblock upper frame</i>	89	-	453
6023		0.755	Traverso inferiore monoblocco <i>Monoblock lower frame</i>	124	-	367
6024		0.235	Coprifilo spalla monoblocco <i>Monoblock cover joint</i>	46	-	137

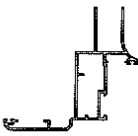
Note:  = Profili po narudžbi

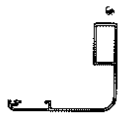
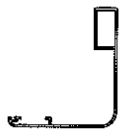
 = Profili na stanju u Sarajevu

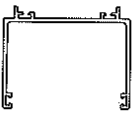
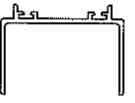
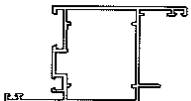
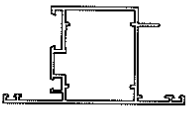
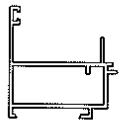

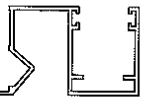
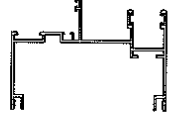

* Ostali profili su na redovnom lageru u Bolonji

Codice Code	Sagoma Shape	Kg/mt.	Descrizione Description	sup. vista mm	Jx cm ⁴	Perim. mm
6025		1.412	Telaio fisso porte interne <i>Fixed frame internal doors</i>	130	-	530
6026		0.893	Imbotte porte interne (80-105mm) <i>For expansion of internal door frames (80/105 mm.)</i>	129	-	331
6027		1.023	Imbotte porte interne (105-130mm) <i>For expansion of internal door frames (105/130 mm.)</i>	154	-	380
6028		1.137	Imbotte porte interne (130-155mm) <i>For expansion of internal door frames (130/155 mm.)</i>	179	-	430
6029		0.715	Espansione imbotte porte interne (155-230mm) <i>For additional expansion of internal door frames (155-230 mm)</i>	75	-	250
6030		0.800	Terminale a muro trasverso <i>Wall terminal compensation (horizontal)</i>	94	-	348
6031		0.570	Terminale a muro montante <i>Wall terminal compensation (vertical)</i>	60	-	253
6038		1.061	Anta a "Z" porte <i>Oversize Z-wing of door</i>	285	12.3	355
6039		1.050	Anta a "T" porte <i>Oversize T-wing of door</i>	285	11.6	355
6040		0.656	Inversione di battuta porte <i>Inversion of rabbet for door</i>	62	-	226
6405		0.160	Asta di comando chiusure <i>Closing rod</i>	14.5	-	49
6909		0.648	Guida per tapparella <i>Rolling shutter guide</i>	62	-	351
7000		1.434	Spalla Bifora <i>Monoblock half-frame</i>	209	-	698

Note:  = Profili po narudžbi

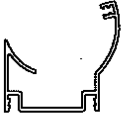
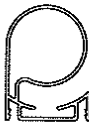
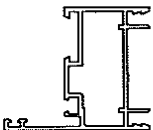
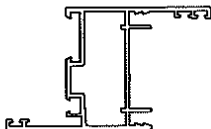
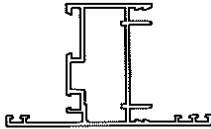
 = Profili na stanju u Sarajevu

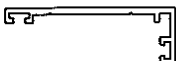
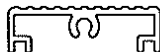
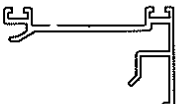
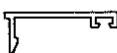



* Ostali profili su na redovnom lageru u Bolonji

Codice Code	Sagoma Shape	Kg/mt.	Descrizione Description	sup. vista mm	Jx cm ⁴	Perim. mm
7005		0.192	Coprifilo bifora <i>Cover joint for monoblock half frame</i>	31	-	101
7009		0.772	Semi angolo orientabile <i>Revolving half-angle</i>	91	-	359
7010		1.126	Semi angolo orientabile <i>Revolving half-angle</i>	139	-	381
7011		0.861	Telaio fisso "L" <i>L-fixed frame</i>	88	-	304
7012		0.986	Telaio fisso "Z" <i>Z-fixed frame</i>	114	-	369
7013		0.986	Telaio fisso "T" <i>T-fixed frame</i>	114	-	369
7015		0.243	Tenuta porte <i>Door seal</i>	8	-	120
7016		0.310	Battuta porte <i>Rabbet for door</i>	19	-	151
7018		0.389	Soglia porte per profili complanari (ante con profili art. 6038-6039) <i>Door threshold for coplanar profile (wing with profiles code 6038-6039)</i>	62	-	169
7019		0.394	Profilo per porte va e vieni <i>For 180° door</i>	75	-	220
7020		0.174	Coprifilo fissato con clips <i>Cover joint fixed with clips</i>	35	-	94
8485		1.156	Cassonetto (profilo centrale) <i>Shutter box (central profile)</i>	224	-	502
8751		0.285	Profilo di compensazione superiore per blocchi <i>Monoblock upper compensator profile</i>	26	-	124

Note:  = Profili po narudžbi

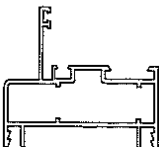
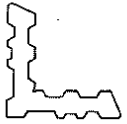
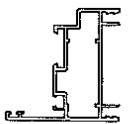
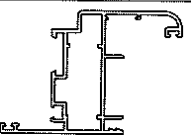
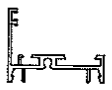
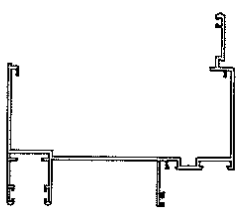
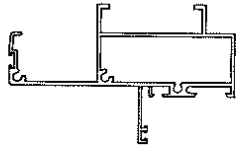
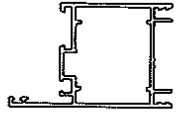
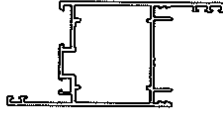
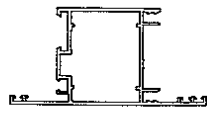
 = Profili na stanju u Sarajevu



* Ostali profili su na redovnom lageru u Bolonji

Codice Code	Sagoma Shape	Kg/mt.	Descrizione Description	sup. vista mm	Jx cm ⁴	Perim. mm
9011		0.975	Abbinamento con serie "PE70 SLIDE" <i>Coupling with PE 70 SLIDE</i>	99	-	489
9026		3.026	Squadretta a cianfrinare (interna) <i>Corner joint to be chamfered (inner)</i>	-	-	-
9030		0.929	Telaio fisso "L" complanare <i>Coplanar L-fixed frame</i>	95	-	465
9031		1.096	Telaio fisso "Z" complanare <i>Coplanar Z-fixed frame</i>	127	-	537
9032		0.569	Soglia ridotta <i>Small threshold</i>	55	-	272
9033		2.095	Spalla monoblocco <i>Monoblock frame</i>	245	-	911
9034		1.566	Traverso superiore monoblocco <i>Monoblock frame</i>	122	-	517
9035		1.034	Telaio fisso "L" maggiorato <i>Oversize L-fixed frame</i>	122	-	339
9036		1.158	Telaio fisso "Z" maggiorato <i>Oversize Z-fixed frame</i>	150	-	404
9037		1.158	Telaio fisso "T" maggiorato <i>Oversize T-fixed frame</i>	150	-	404
9040		0.321	Fermavetro a scatto (L = 29) <i>Snap coupled glass beading</i>	51	-	189
9041		0.311	Fermavetro arrotondato a scatto (L = 29) <i>Snap type rounded glass beading</i>	49	-	183
9042		0.289	Fermavetro arrotondato a clips (L = 29) <i>Rounded glass beading fixed with clips</i>	47	-	144

Note:  = Profili po narudžbi

 = Profili na stanju u Sarajevu

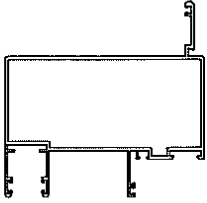
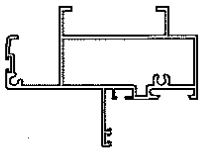
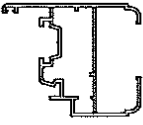
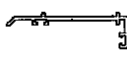
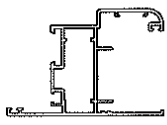
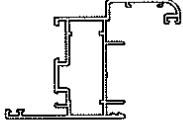
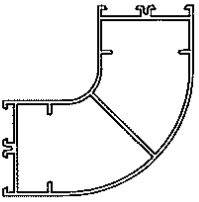
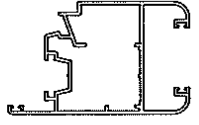
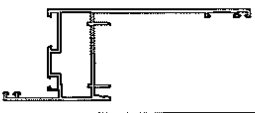

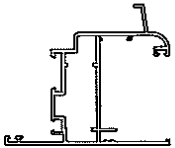
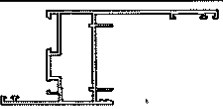



* Ostali profili su na redovnom lageru u Bolonji

Codice Code	Sagoma Shape	Kg/mt.	Descrizione Description	sup. vista mm	Jx cm ⁴	Perim. mm
9044		2.392	Spalla monoblocco Monoblock frame	229	-	702
9047		1.493	Traverso superiore monoblocco Monoblock upper frame	106	-	485
9131		1.040	Anta persiana o con vetro ad infilare Shutter wing or for glass to be inserted	130	14.46	382
9137		0.381	Battuta inferiore con gocciolatoio Lower rabbet with water drainage	35	-	183
9148		1.177	"L" soglia "L" threshold	151	-	446
9149		1.072	Telaio fisso "Z" complanare Coplanar Z-fixed frame	127	-	394
9150		1.909	Angolo a 90° Angle to 90°	229	-	401
9154		1.385	Anta vetro infilare maggiorata For oversize wing with glass to be inserted	180	20.3	451
9155		1.231	Telaio fisso battuta 70mm Z-fixed frame with 70 mm. rabbet fin	163	-	461
9159		0.249	Fermavetro a scatto (L=10) Snap coupled glass beading	32	-	149
9160		1.242	"L" soglia complanare Coplanar "L" threshold	162	-	476
9161		1.123	Telaio fisso battuta 50mm Z-fixed frame with 50 mm. rabbet fin	143	-	422

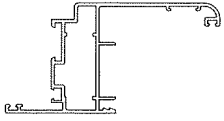
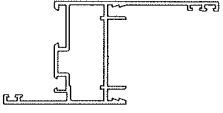
Note:  = Profili po narudžbi

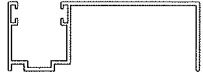
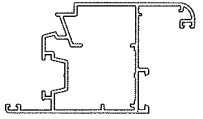
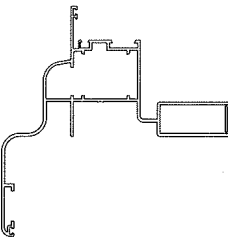
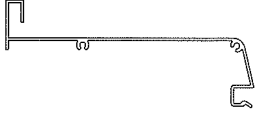
 = Profili na stanju u Sarajevu

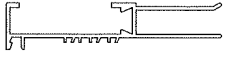

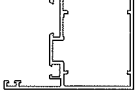
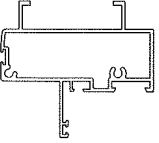
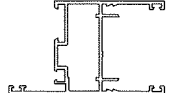



* Ostali profili su na redovnom lageru u Bolonji

Codice Code	Sagoma Shape	Kg/mt.	Descrizione Description	sup. vista mm	Jx cm ⁴	Perim. mm
9162		1.223	Telaio fisso complanare battuta 50 mm <i>Complanar Z-fixed frame with 50 mm rabbet fin</i>	153	-	460
9168		1.058	Telaio fisso battuta 40 mm <i>Z-fixed frame with 40 mm rabbet fin</i>	131	-	405
9175		0.365	Fermavetro a scatto <i>Snap coupled glass beading</i>	62	-	210
9404		0.751	Guida per tapparella <i>Rolling shutter guide</i>	125	-	379
9533		1.331	Anta maggiorata <i>Oversize wing</i>	151	19,3	417
9609		2.643	Telaio fisso per imbotte <i>For expansion fixed frame</i>	310	-	784
10342		1.405	Cassonetto (superiore ed inferiore) <i>Shutter box (upper and lower profile)</i>	186	-	587
11015		0.551	Riparto per spalla monoblocco <i>Additional monoblock frame</i>	40	-	250
11016		0.842	Traverso superiore monoblocco <i>Monoblock upper frame</i>	45	-	397
11017		0.575	Rinforzo per centinatura profili <i>Reinforcement bended profiles</i>	-	-	73
11021		0.899	Telaio "L" liscio maggiorato <i>Oversize flat L-fixed frame</i>	151	-	271
11023		1.326	Traverso superiore monoblocco <i>Monoblock upper frame</i>	61	-	388
11027		1.085	"L" soglia <i>L-threshold</i>	141	-	418

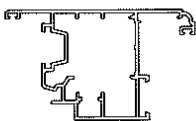
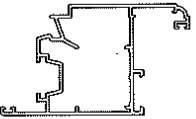
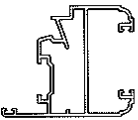
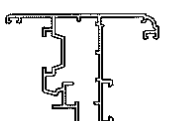
Note:  = Profili po narudžbi

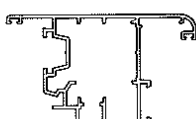
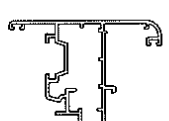
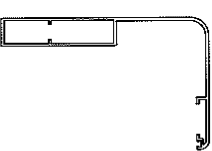
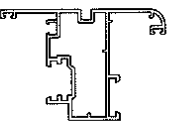
 = Profili na stanju u Sarajevu

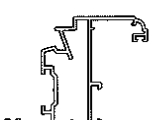







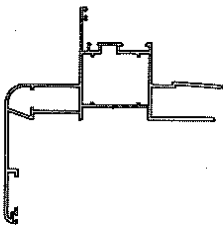
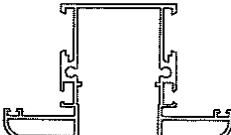
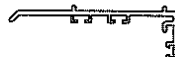

* Ostali profili su na redovnom lageru u Bolonij

Codice Code	Sagoma Shape	Kg/mt.	Descrizione Description	sup. vista mm	Jx cm ⁴	Perim. mm
11028		1.391	Anta apertura esterna maggiorata <i>External opening oversize wing</i>	159	19,26	420
11029		1.312	Anta maggiorata <i>For oversize wing</i>	153	19,19	417
11031		1.121	Anta vetro infilare <i>For wing with glass to be inserted</i>	134	15,35	400
11032		1.142	Anta apertura esterna <i>External opening wing</i>	123	13,95	381
11044		0.300	Fermavetro cieco <i>Blind glass beading</i>	63	-	150
11054		1.388	Anta apertura esterna maggiorata <i>External opening oversize wing</i>	159	19,73	420
11055		1.136	Anta apertura esterna <i>External opening wing</i>	123	14,51	381
11059		1.631	Imbotte porte interne da mm. 135 <i>For expansion of internal door frames (dim. 135 mm)</i>	219	-	510
11075		1.204	Anta a "T" <i>T-wing</i>	144	16,06	420
11084		0.316	Fermavetro a scatto (L = 27) <i>Snap coupled glass beading</i>	49	-	185
11099		0.254	Fermavetro arrotondato a scatto (L = 15) <i>Snap type rounded glass beading</i>	33	-	141
11201		1.045	Anta <i>For wing</i>	109	14,17	363
11202		0.281	Fermavetro a scatto (L = 23) <i>Snap coupled glass beading</i>	42	-	178

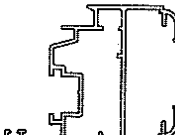
Note:  = Profili po narudžbi

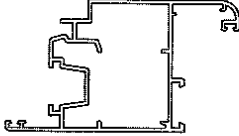
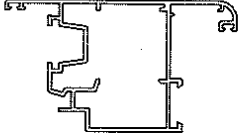
 = Profili na stanju u Sarajevu



* Ostali profili su na redovnom lageru u Bolonji

Codice Code	Sagoma Shape	Kg/mt.	Descrizione Description	sup. vista mm	Jx cm ⁴	Perim. mm
11203		0.232	Fermavetro arrotondato a scatto (L = 13) <i>Snap type rounded glass beading</i>	32	-	147
14371		0.250	Fermavetro arrotondato a scatto (L = 17) <i>Snap type rounded glass beading</i>	35	-	153
14536		2.364	Telaio fisso per imbotte <i>For expansion fixed frame</i>	258	-	754
14539		1.522	"T" da 89 mm arrotondato per ante <i>Rounded T-profile 89 mm. for wing</i>	151	18,37	529
14555		0.496	Battuta inferiore con gocciolatoio <i>Lower rabbet with water drainage</i>	49	-	234
16104		0.290	Compensatore per persiana fissa <i>Compensator for fixed shutter</i>	70	-	158
16123		1.178	Anta persiana o con vetro ad infilare <i>Shutter wing or for glass to be inserted</i>	172	16,52	414
16307		0.311	Fermavetro arrotondato a scatto (L = 17) <i>Snap type rounded glass beading</i>	49	-	189
16753		1.380	Anta maggiorata <i>For oversize wing</i>	166	20,01	435
16754		1.386	Anta maggiorata apertura esterna <i>For oversize wing external opening</i>	166	18,70	435
16802		0.358	Profilo per porte va e vieni <i>For 180° door</i>	34	-	187
16803		0.435	Profilo per porte va e vieni <i>For 180° door</i>	51	-	220
16805		0.658	Battuta riportata da 80 mm <i>Additional rabbet 80 mm</i>	78	-	266

Note:  = Profili po narudžbi

 = Profili na stanju u Sarajevu

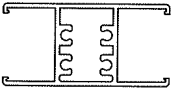
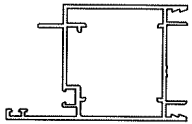
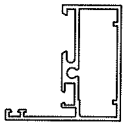
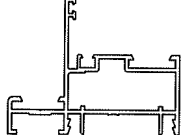
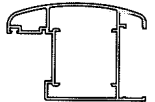
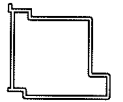
* Ostali profili su na redovnom lageru u Bolonji

Codice Code	Sagoma Shape	Kg/mt.	Descrizione Description	sup. vista mm	Jx cm ⁴	Perim. mm
16808		0.294	Fermavetro arrotondato a scatto (L=27) <i>Snap type rounded glass beading</i>	45	-	180
16810		1.166	Fascia da 65 mm. vetro infilare <i>Horizontal transom for glass to be inserted</i>	142	6.61	294
16811		1.061	Telaio "L" per porte apertura esterna <i>L-fixed frame for outward opening door</i>	139	-	341
16818		0.782	Telaio "L" liscio <i>Flat L-fixed frame</i>	71	-	245
16819		1.058	Telaio fisso "L" con fissaggio laterale <i>L-fixed frame with side fixing</i>	93	-	393
19705		1,083	Anta persiana <i>Shutter wing</i>	142	-	303
19706		0,511	Battuta centrale per profilo 19705 <i>Central rabbet for profile 19705</i>	51	-	153
19715LV		0,258	Profilo pretranciato per persiana fissa con ovalina Z0682 <i>Pre-blanking profile for fixed shutter with Z0682 slat</i>	34	-	142
19716		0,399	Compensatore per persiana fissa <i>Compensator for fixed shutter</i>	74	-	205









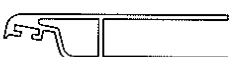

* NOTA BENE:

4200 - 4201 - 4260 - 4261 - 4262 - 4266 - 4267 - 4268

Note:  = Profili po narudžbi

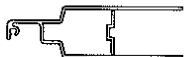
 = Profili na stanju u Sarajevu

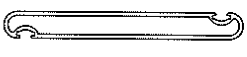
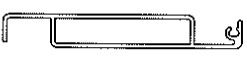
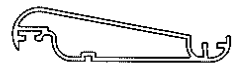
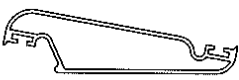





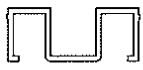
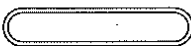

* Ostali profili su na redovnom lageru u Bolonji

Codice Code	Sagoma Shape	Kg/mt.	Descrizione Description	sup. vista mm	Jx cm ⁴	Perim. mm
PE3310		0.294	Compensatore piccolo persiana Teknalsystems <i>Small compensator Teknalsystem shutter</i>	82	-	178
PE3378		0.309	Compensatore piccolo persiana Per.la 70 Naco <i>Small compensator Per.la 70 Naco shutter</i>	83	-	126
PE3379		0.158	Jolly persiana Per.la 70 Naco <i>Jolly Per.la 70 Naco shutter</i>	39	-	95
PE3382		0.450	Compensatore grande persiana Per.la 70 Naco <i>Big compensator Per.la 70 Naco shutter</i>	127	-	214
PE5567		0.561	Compensatore persiana Ovalina Metaltecnica <i>Compensator for Ovalina Metaltecnica shutter</i>	116	-	247
PE6016		0.367	Compensatore per persiana fissa <i>Compensator for fixed shutter</i>	87	-	186
PE6017		0.216	Chiudi canale per persiana <i>Shutter window cap</i>	35	-	220
PE6306		0.613	Chiudi persiana Perlina Metaltecnica <i>Compensator for Perlina Metaltecnica shutter</i>	155	-	275
PE7014		0.238	Guida per persiana SP 54 Naco <i>Guide for SP 54 Naco shutter slat</i>	26	-	130
SO1298		0.435	Lamella fissa e blindata persiana Kikau <i>Fixed and armor-plated slat for Kikau shutter</i>	147	-	136
SO1763		0.506	Lamella orientabile pesiana Ovalina Metaltecnica <i>Revolving Ovalina Metaltecnica shutter slat</i>	154	-	169
SO1921		0.486	Lamella orientabile pesiana Perlina Metaltecnica <i>Revolving Perlina Metaltecnica shutter slat</i>	130	-	198
SO3307		0.531	Lamella orientabile pesiana Universal Teknalsystems <i>Revolving Universal Teknalsystem shutter slat</i>	125	-	193
SO3381		0.531	Lamella pesiana apribile e fissa Per.la 70 Naco <i>Opening and fixed slat Per.la 70 Naco shutter</i>	140	-	196
SO3396		0.689	Lamella orientabile persiana Primera Teknalsystems	158	-	214

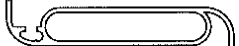
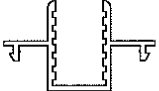
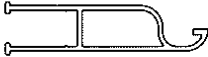
Note:  = Profili po narudžbi

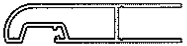
 = Profili na stanju u Sarajevu

* Ostali profili su na redovnom lageru u Bolonji

Codice Code	Sagoma Shape	Kg/mt.	Descrizione Description	sup. vista mm	Jx cm ⁴	Perim. mm
S07353		0.332	Guida per persiana apribile e fissa Per.la 70 Naco Guide opening and fixed slat Per.la 70 Naco shutter window	23	-	178
Z0682		0.422	Ovalina da mm.50 per persiana fissa 50 mm slat for fixed shutter	112	-	111
Z01254		0.542	Lamella orientabile persiana K 70 Kikau Revolving K 70 Kikau shutter slat	165	-	220
Z01262		0.405	Compensatore persiana K 70 Kikau Kikau shutter compensator	113	-	185
Z01316		0.382	Lamella orientabile per persiana SP 54 Naco Revolving slat for SP 54 Naco shutter	97	-	175
Z03309		0.379	Guida per persiana Teknalsystems Guide for Teknalsystem shutter window	47	-	209
Z03311		0.397	Compensatore grande persiana Teknalsystems Big compensator Teknalsystem shutter window	93	-	180
Z04343		0.562	Lamella orientabile persiana K 60 Kikau Revolving K 60 Kikau shutter slat	178	-	182
Z04377		0.443	Compensatore persiana K 60 Kikau Compensator for shutter	130	-	186
Z05565		1.693	Fascia/zoccolo per persiana Metaltecnica Central or lower horizontal transom for Metaltecnica shutter	270	-	467
Z05566		1.166	Traverso persiana Ovalina Metaltecnica Transom for Ovalina Metaltecnica shutter	285	-	288
Z06307		1.191	Traverso persiana Perlina Metaltecnica Transom for Perlina Metaltecnica shutter	349	-	344
Z06344		1.523	Fascia/zoccolo per persiana Kikau Central or lower horizontal transom for Kikau shutter	249	-	399

Note:  = Profili po narudžbi

 = Profili na stanju u Sarajevu

* Ostali profili su na redovnom lageru u Bolonji

ARTICOLO ACCESSORIO ACCESSORY ITEM	APPLICAZIONE SUL SISTEMA E DESCRIZIONE DESCRIPTION AND SYSTEM APPLICATION	ARTICOLO ACCESSORIO ACCESSORY ITEM	APPLICAZIONE SUL SISTEMA E DESCRIZIONE DESCRIPTION AND SYSTEM APPLICATION
100-600X	CERNIERA A PETTINE "BRIDGE 2" "BRIDGE 2" HINGE	100-1458	FRIZIONE PER BILICO (coppia) FRICTION JOINT FOR PIVOT
100-607X	CERNIERA A PETTINE "BRIDGE 2" (per terza anta) "BRIDGE 2" HINGE (for third wing)	100-1650	MANIGLIA A TAVELLINO "BRAVO2" "BRAVO2" HANDLE
100-120N	CERNIERA "FLASH" "FLASH" HINGE	100-1701	CRICCHETTO "GRISBI" SPRING LATCH FOR HOPPER WINDOWS
100-143V	CERNIERA "FLASH" (per terza anta) "FLASH" HINGE (for third wing)	100-1954	ASTA TELESCOPICA "LASER" "LASER" TELESCOPIC ROD
100-0150N	CERNIERA "FLASH" CON PERNO REGISTRABILE "FLASH" HINGE WITH ADJUSTABLE PIN	100-2014	BRACCIA SGANCIABILE "DOMUS" "DOMUS" RELEASABLE ARM
153-0428	GIUNTO A "T" (29x15) T-JOINT	100-2030	BRACCIO LIMITATORE DI APERTURA FRICTION OF LIMITED OPENING ARM
153-0431	GIUNTO A "T" (27,5x32) T-JOINT	100-2040	BRACCIO LUNGO "RALLENTY" mm 250 "RALLENTY" LONG ARM 250 mm
100-1000	CREMONESE "EURO" "EURO" CREMONE BOLT	100-2041	BRACCIO CORTO "RALLENTY" mm 150 "RALLENTY" SHORT ARM 150 mm
100-1004	CREMONESE "NOVA" "NOVA" CREMONE BOLT	100-2051	CERNIERA PER WASISTAS "OLIMPIA" (coppia) "OLIMPIA" HINGE FOR HOPPER WINDOWS
100-1009	CREMONESE "NOVA" (con cursori allungati) "NOVA" CREMONE BOLT (with long plate)	100-2111	CATENACCIO "GIAP" "GIAP" LATCH
100-1025	MOVIMENTAZIONE INTERNA BIDIREZIONALE PER BILICO BIDIRECTIONAL INTERNAL HANDLING FOR PIVOT	100-2113	ASTA DI PROLUNGA EXTENSION ROD
100-1090N	CREMONESE "EURO" PER MECCANISMO ANTA-RIBALTA "EURO" CREMONE BOLT FOR TILT-TURN WINDOW	100-2114	TERMINALE PER ASTE ROD TERMINAL
100-1314	INCONTRO ASTE E TERZA CHIUSURA REST PLATE AND 3RD STOP	100-2153	CATENACCIO "SUPERGIAP" "SUPERGIAP" LATCH FOR
100-1325	INCONTRO SUPERIORE CATENACCIO "TOTEM" UPPER REST PLATE FOR DOOR LATCH	100-2157	TERMINALE PER ASTE "SUPERGIAP" "SUPERGIAP" ROD TERMINAL
100-1339	INCONTRO DOPPIO DOUBLE REST PLATE	100-2159	BOCCOLA PER SOGLIA DOOR SILL BUSH
100-1343	INCONTRO PER ART. 100-4030 REST PLATE FOR ITEM 100-4030	100-2170	CATENACCIO "TOTEM" PER PORTE "TOTEM" LATCH FOR DOOR
100-1350	ROSTRO DI CHIUSURA REGISTRABILE ADJUSTABLE ADDITIONAL HINGE	100-2172	CATENACCIO "TOTEM" "TOTEM" LATCH FOR WINDOWS
		100-2250	KIT DI COLLEGAMENTO CREMONESE "NOVA" PER APER- TURE ESTERNE (per profilo (4274) "NOVA" CREMONE BOLT CONNECTING KIT FOR EXTERNAL OPENINGS (for profile 4274)

ARTICOLO ACCESSORIO ACCESSORY ITEM	APPLICAZIONE SUL SISTEMA E DESCRIZIONE DESCRIPTION AND SYSTEM APPLICATION	ARTICOLO ACCESSORIO ACCESSORY ITEM	APPLICAZIONE SUL SISTEMA E DESCRIZIONE DESCRIPTION AND SYSTEM APPLICATION
100-2296	KIT DI COLLEGAMENTO CREMONESE "NOVA" PER APERTURE ESTERNE (per prof. persiana 5680) "NOVA" CREMONE BOLT CONNECTING KIT FOR EXTERNAL OPENINGS (for prof. shutter 5680)	101-6192	CERNIERA "LOIRA" A DUE ALI INTERASSE mm 93 93 mm CENTER DISTANCE "LOIRA" HINGE
100-2252	PERNO PER TRASCINAMENTO PER KIT ART. 100-2250/100-2296 (perno da mm 13) TRAILING PIN FOR KIT ITEM 100-2250/100-2296 (pivot mm 13)	101-6197	CERNIERA "LOIRA" A TRE ALI INTERASSE mm 93 93 mm CENTER DISTANCE "LOIRA" HINGE
100-2255	PERNO DI TRASCINAMENTO PER KIT ART. 100-2250/100-2296 (perno da mm 28) TRAILING PIN FOR KIT ITEM 100-2250/100-2296 (pivot mm 28)	101-6633	KIT FISSAGGIO PER CERNIERA art. 101-6192 FIXING KIT FOR HINGE ITEM 101-6192
100-2328	CAPPETTA COPRI ASOLA DRENAGGIO ACQUA COVER CAP FOR WATER DRAINAGE HOLE	101-6643	KIT FISSAGGIO PER CERNIERA art. 101-6197 FIXING KIT FOR HINGE ITEM 101-6197
100-2336	SOSTEGNO ANTA WING SUPPORT	101-6851	DIMA PER PANTOGRAFO (interasse 60 mm) PANTOGRAPH TEMPLATE
100-2346	TAPPO RACCOGLICONDENSA LATERAL PLUG FOR CONDENSATION COLLECTION	101-6856	DIMA PER PANTOGRAFO (interasse 93 mm) PANTOGRAPH TEMPLATE
100-2387	BLOCCHETTI DI COLLEGAMENTO ALLA CREMONESE "EURO" "EURO" CREMONE BOLT CONNECTION BLOCKS	104-600.01	RAPID BLOCK Z/P RAPID BLOCK Z/P
100-2460	MARTELLINA "MASTERMAR" "MASTERMAR" HANDLE	104-600.98	SPESSORE/SHIM mm 5
100-4020	RINVIO D'ANGOLO PER CHIUSURE PERIMETRALI ANGLE TRANSMISSION FOR PERIMETER CLOSING	104-600.99	SPESSORE/SHIM mm 2,5
100-4030	NOTTOLINO DI CHIUSURA REGISTRABILE ADJUSTABLE CLOSING PIN	104-RB645	SPESSORE PER CORPO Z/P Z/P BODY SHIM
101-6040	CERNIERA "LOIRA" A DUE ALI INTERASSE mm 60 CON KIT DI FISSAGGIO 60 mm CENTER DISTANCE "LOIRA" HINGE WITH FIXING KIT	105-0099	SPINA PER SQUADRETTA art. 105-0110 PIN FOR CORNER JOINT ITEM 105-0110
101-6045	CERNIERA "LOIRA" A TRE ALI INTERASSE mm 60 CON KIT DI FISSAGGIO 60 mm CENTER DISTANCE "LOIRA" HINGE WITH FIXING KIT	105-0110	SQUADRETTA CERVINO A SPINARE O CIANFRINARE CORNER JOINT TO BE LOCKED BY A PIN OR TO BE CHAMFERED
		105-0409 164-0409	SQUADRETTA A SCATTO "MONTEBIANCO" CORNER JOINT
		105-0426 164-0426	SQUADRETTA A SCATTO "MONTEBIANCO" PER PROFILI A TUBOLARITÀ MAGGIORATA CORNER JOINT FOR OVERSIZE PROFILES



ARTICOLO ACCESSORIO ACCESSORY ITEM	APPLICAZIONE SUL SISTEMA E DESCRIZIONE DESCRIPTION AND SYSTEM APPLICATION	ARTICOLO ACCESSORIO ACCESSORY ITEM	APPLICAZIONE SUL SISTEMA E DESCRIZIONE DESCRIPTION AND SYSTEM APPLICATION
105-0706	SQUADRETTA IN ACCIAIO INOX PER ALLINEAMENTO ALETTE DI BATTUTA TELAIO A MURO <i>STAINLESS STEEL CORNER JOINT FOR WALL SUBFRAME</i>	106-2773001	SELLA ELASTICA PER OVALINA FISSA (profilo persiana 16123) <i>ELASTIC SADDLE FOR FIXED SLAT (window shutter profile 16123)</i>
105-1909	SQUADRETTA A SCATTO AD ANGOLAZIONE VARIABILE <i>CORNER JOINT WITH VARIABLE ANGULATION</i>	106-2774001	MEZZA SELLA ELASTICA PER OVALINA FISSA (profilo 16123) <i>HALF ELASTIC SADDLE FOR FIXED SLAT (profile 16123)</i>
105-5004/50	SQUADRETTA AD AVVITARE PER PROFILI MAGGIORATI "TONALE" <i>"TONALE" CORNER JOINT TO BE SCREWED FOR OVERSIZE PROFILES</i>	110-B869 169-S3393 (in PVC)	SQUADRA DI ALLINEAMENTO IMBOTTI PORTE INTERNE <i>CORNER JOINT FOR INTERNA DOOR</i>
106-0349	FORBICI TAGLIA GUARNIZIONI <i>SCISSORS FOR GASKET</i>	110-3578	SQUADRA IN ALLUMINIO A SPINARE SU PROFILI A SEZ. MAGGIORATA <i>ALUMINIUM CORNER JOINT TO BE LOCKED BY A PIN ON OVERSIZE PROFILES</i>
106-1116	SELLA REVERSIBILE PER OVALINA FISSA (PER INSERIMENTO IN PROFILO PERSIANA 5680) <i>REVERSIBLE SADDLE FOR FIXED SLAT (FOR INSERTION WINDOW SHUTTER PROFILE 5680)</i>	153-3579	SQUADRA IN ALLUMINIO A CIANFRINARE SU PROFILI A SEZ. MAGGIORATA <i>ALUMINIUM CORNER JOINT TO BE CHAMFERED ON OVERSIZE PROFILES</i>
106-00114	ROTELLA INFILA GUARNIZIONE <i>ROLLER FOR GASKET INSERTION</i>	115-CD2775	TAPPO PER PROFILO 19706 <i>PLUG FOR PROFILE 19706</i>
106-1863	KIT SPESSORI REGISTRO PER VETRI (PER INSERIMENTO IN PROFILI A VETRO AD INFILARE) - (con registro da mm 10) <i>SHIM AND REGULATOR KIT FOR GLASSES (FOR PROFILE WITH GLASS TO BE INSERTED)</i>	123-50729T	SIGILLANTE PROTETTIVO TRASPARENTE PER LA SIGILLATURA ANGOLI <i>TRASPARENT FOR CORNERS</i>
106-1864	KIT SPESSORI REGISTRO PER VETRI (PER INSERIMENTO IN PROFILI A VETRO AD INFILARE) - (con registro da mm 18) <i>SHIM AND REGULATOR KIT FOR GLASSES (FOR PROFILE WITH GLASS TO BE INSERTED)</i>	124-P896/T	CONTROPIASTRA PER PORTE INTERNE CON ANTA IN ALLUMINIO <i>SUBBOARD FOR ALUMINIUM WING INTERNAL DOORS</i>
106-1905	GIUNTO PER TRAVERSO PERSIANA (5681) <i>JOINT FOR SHUTTER TRANSOM PROFILE</i>	124-P1042/20	CONTROPIASTRA PER PORTE CON PANNELLO IN LEGNO <i>SUBBOARD FOR WOODEN PANEL DOORS</i>
106-1906	TAPPO TERMINALE PER PROFILO PERSIANA (5680) <i>LOWER PLUG FOR SHUTTER PROFILE 5680</i>	124-P2286	SPESSORE CHIUSURA PER ANTA IN ALLUMINIO PORTE INTERNE <i>CLOSING SHIM FOR ALUMINIUM WING INTERNAL DOOR</i>
106-1907	TAPPO TERMINALE PER RIPORTO CENTRALE PERSIANA (4263) <i>LOWER PLUG FOR CENTRAL PROFILE</i>	124-TB80	SCROCCO PER PORTE INTERNE (R) <i>INTERNAL DOOR LATCH</i>
106-2065	GIUNTO PER PROFILI: 4264 - 4276 - 4277 - 4278 <i>JOINT FOR PROFILE: 4264 - 4276 - 4277 - 4278</i>	124-12 124-13 124-15	MANIGLIA PER PORTE INTERNE <i>INTERNAL DOOR HANDLE</i>
		126-6117	TAPPO DI TENUTA SU INVERSIONE CENTRALE PORTE <i>SEAL PLUG ON CENTRAL DOOR INVERSION</i>
		126-6118	TAPPO SU PROFILI DI BATTUTA PORTE <i>RABBET PLUG ON THRESHOLD OF DOOR BASES</i>

ARTICOLO ACCESSORIO ACCESSORY ITEM	APPLICAZIONE SUL SISTEMA E DESCRIZIONE DESCRIPTION AND SYSTEM APPLICATION	ARTICOLO ACCESSORIO ACCESSORY ITEM	APPLICAZIONE SUL SISTEMA E DESCRIZIONE DESCRIPTION AND SYSTEM APPLICATION
126-6137	SQUADRETTA DI ALLINEAMENTO ALETTA ESTERNA TELAI CORNER JOINT FOR EXTERNAL FRAME	126-93497 142-2105	TAPPI DI TENUTA SU PROFILO DI RIPORTO CENTRALE PER GUARNIZIONE A GIUNTO APERTO SEAL PLUG ON CENTRAL PROFILE FOR CENTRAL GASKET
126-6140	CLIPS DI AGGANCIAMENTO PER COPERTINE PROFILI PER ANGOLO VARIABILE CONNECTION CLIPS FOR VARIABLE ANGLE AND COVER JOINT	126-93517 142-2104	CONF. TAPPI DI TENUTA SU PROFILO DI RIPORTO CENTRALE CON GUARNIZIONE IN DOPPIA BATTUTA SEAL PLUG ON CENTRAL PROFILE WITH DOUBLE RABBET GASKET
126-6312	SQUADRETTA DI ALLINEAMENTO ALETTA INTERNA ANTE CORNER JOINT FOR INTERNAL FIN WING	142-2224 164-2224	ANGOLO IN ZAMA PER FERMAVETRI ARROTONDATI ANGLE FOR ROUNDED GLASS BEADINGS
130-1326	CAVALLOTTO IN ACCIAIO PER GIUNZIONE A CROCE STEEL CORNER JOINT FOR CROSS	170-892100115	COLLANTE MONOCOMPONENTE PER INCOLAGGIO SQUADRETTA SINGLE-COMPONENT GLUE FOR CORNER JOINT
130-0610	CERNIERE PER PORTE INTERNE CON PANNELLO DI LEGNO HINGES FOR INTERNAL WOODEN PANEL DOORS	153-0002	SQUADRETTA CIANFRINARE SU IN ALLUMINIO ESTRUSO ESTRUDET ALUMINIUM CORNER JOINT TO BE CHAMFERED
131-8973	TAPPI IN P.V.C. NERO PER CASSONETTO MONOBLOCCO BLACK, P.V.C. PLUG FOR MONOBLOCK BOX	156-034	INVITO AVVOLGIBILE PER PROF 9404 COUPLING OF PROF 9404 ROLLING SHUTTER
131-8998	MENSOLE ORIZZONTALI IN LAMIERA ZINCATA PER MONOBLOCCO GALVANIZED STEEL HORIZONTAL SHELFS FOR MONOBLOCK	157-0104	COPPIA COPRIBORDO PER PROFILO (10342) COVER PLUG FOR PROFILE 10342
131-PR9064	COPPIA INVITI TAPPARELLA MONOBLOCCO CON PASSACINTINO COUPLING OF MONOBLOCK ROLLING SHUTTER WITH BELT PASS	157-0105	KIT TAPPI GIUNZIONE CENTRALE "Z-T" PROFILO 11075 SEAL PLUGS KIT FOR CENTRAL SECTION "Z-T" PROFILE 11075
131-RA442	COPPIA POMOLINI CON VITE COUPLE OF KNOBS WITH SCREW	157-0238	TAPPO TERMINALE PER PROFILO PERSIANA (16123) LOWER PLUG FOR SHUTTER PROFILE (16123)
131-RA546	AVVOLGITORE CINTINO DA m 5 CON PLACCA NERA 5 mt BELT WINDER WITH BLACK PLATE	210-T2974	SPINA IN ZAMA PER SQUADRA ART. 110-3578 PIN FOR CORNER JOINT ITEM 110-3578
131-RA547	AVVOLGITORE CINTINO DA m 8 CON PLACCA NERA 8 mt BELT WINDER WITH BLACK PLATE	653-040.4	SQUADRETTA DI ALLINEAMENTO ESTERNA TELAI E ANTE CORNER JOINT FOR EXTERNAL FRAME AND WING
131-RA548	CASSETTA PER AVVOLGITORE WINDER HOUSING	N.B.	PER ACCESSORI STANDARD NON A STOCK, DEL MONOBLOCCO CONSULTARE PAG. 105 FOR STANDARD MONOBLOCK, ACCESSORIES, NOT IN STOCK, SEE PAG. 105
131-RA552	CUSCINETTO A SFERE BALL BEARING		
126-6183	CLIPS DI AGGANCIAMENTO PER FERMAVETRI ARROTONDATI CONNECTION CLIPS FOR ROUNDED GLASS BEADING		

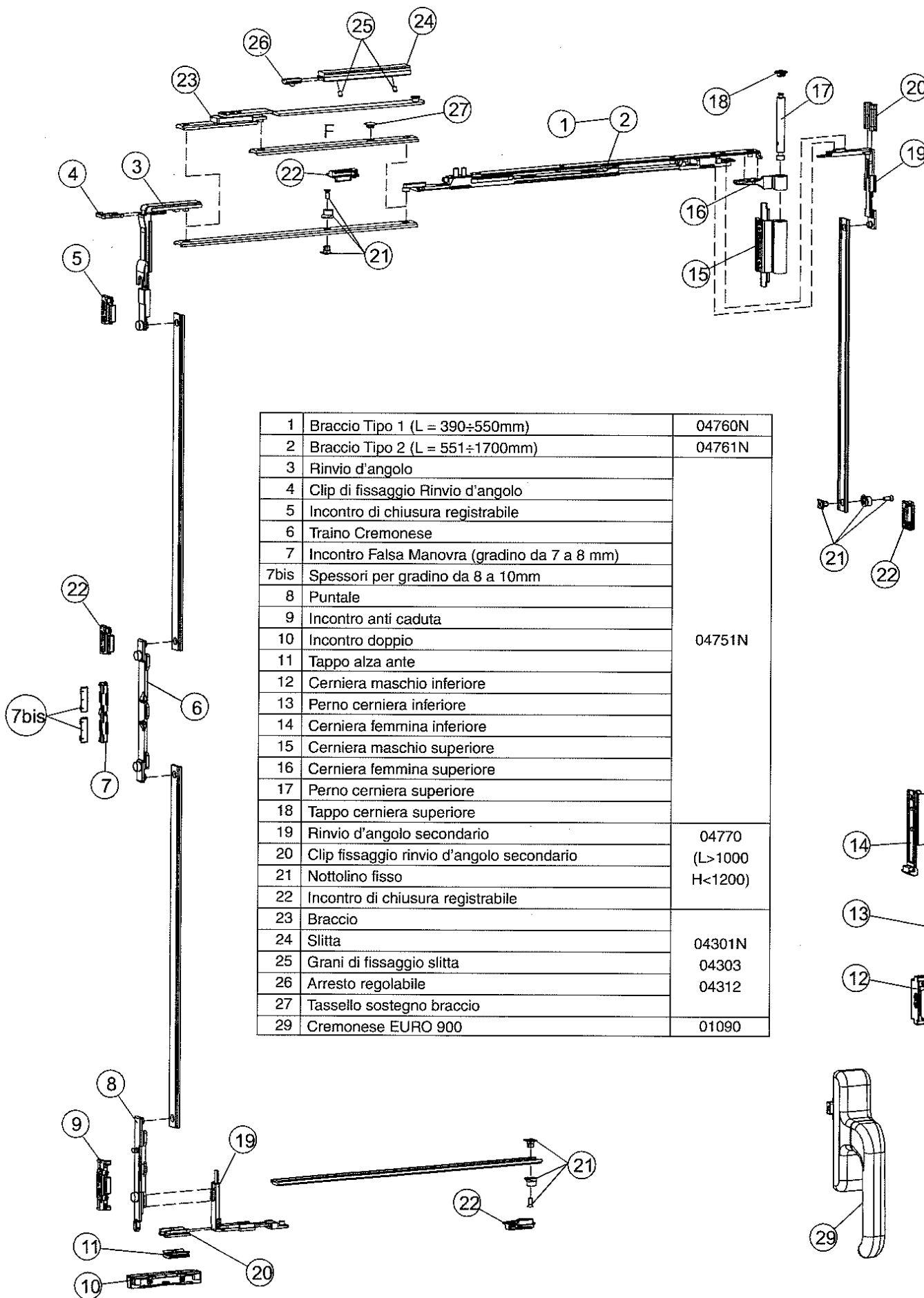
100-4751N

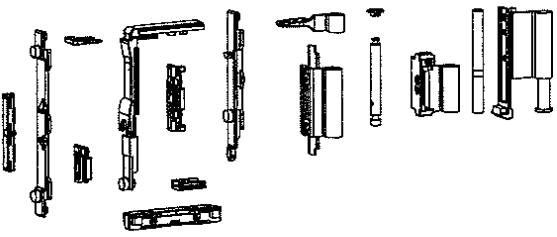

1	Braccio Tipo 1 (L = 390÷550mm)	04760N
2	Braccio Tipo 2 (L = 551÷1700mm)	04761N
3	Rinvio d'angolo	
4	Clip di fissaggio Rinvio d'angolo	
5	Incontro di chiusura registrabile	
6	Traino Cremonese	
7	Incontro Falsa Manovra (gradino da 7 a 8 mm)	
7bis	Spessori per gradino da 8 a 10mm	
8	Puntale	
9	Incontro anti caduta	
10	Incontro doppio	04751N
11	Tappo alza ante	
12	Cerniera maschio inferiore	
13	Perno cerniera inferiore	
14	Cerniera femmina inferiore	
15	Cerniera maschio superiore	
16	Cerniera femmina superiore	
17	Perno cerniera superiore	
18	Tappo cerniera superiore	
19	Rinvio d'angolo secondario	04770
20	Clip fissaggio rinvio d'angolo secondario	(L>1000 H<1200)
21	Nottolino fisso	
22	Incontro di chiusura registrabile	
23	Braccio	
24	Slitta	04301N
25	Grani di fissaggio slitta	04303
26	Arresto regolabile	04312
27	Tassello sostegno braccio	
29	Cremonese EURO 900	01090

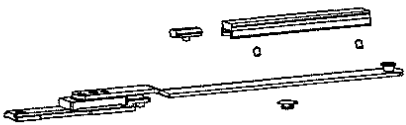
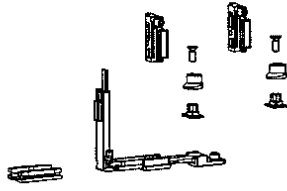
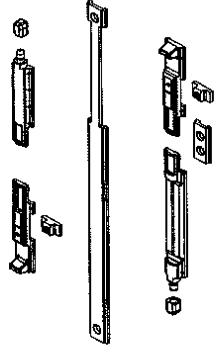
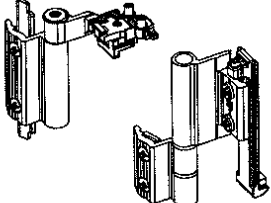
	<p>MECCANISMO BASE ANTA RIBALTA FUTURA</p> <p>100-4751N Composto da tutta la ferramenta di scorrimento (rinvio, traino e puntale) dagli incontri da porre sul telaio e dalle cerniere (premontate).</p>
	<p>BRACCIO ANTA RIBALTA FUTURA</p> <p>100-4760N Braccio tipo 1 necessario da 390 a 550mm</p> <p>100-4761N Braccio tipo 2 necessario da 550 a 1700mm</p>
	<p>BRACCIO SUPPLEMENTARE ANTA RIBALTA FUTURA</p> <p>100-4301N</p>
	<p>CHIUSURA SUPPLEMENTARI ORIZZONTALI O VERTICALI PER ANTA RIBALTA FUTURA</p> <p>100-4770 Opportuno per la realizzazione di chiusure supplementari su ante con L > 1000mm e H > 1200mm (qualora fossero da realizzare sia alla chiusura verticale che quella orizzontale, saranno necessari due pezzi)</p>
	<p>CATENACCIO GIAP PER ANTA ABBINATA AD ANTA RIBALTA FUTURA</p> <p>100-4274 Catenaccio per anta abbinata caratterizzato dai terminali con corpo in nylon e perno di chiusura in acciaio dotato di boccia con cui è possibile regolare la compressione in battuta.</p> <p>Manovra a scatto.</p>
	<p>CERNIERA PER ANTA ABBINATA AD ANTA RIBALTA FUTURA</p> <p>100-4771 Stessa estetica delle cerniere del meccanismo anta ribalta.</p> <p>Le cerniere sono fornite premontate e quindi pronte per essere installate.</p>



N.B.: Per lavorazioni e montaggio seguire le istruzioni del foglio illustrativo inserito nel kit.

For tooling and mounting follow the instructions leaflet in the kit.

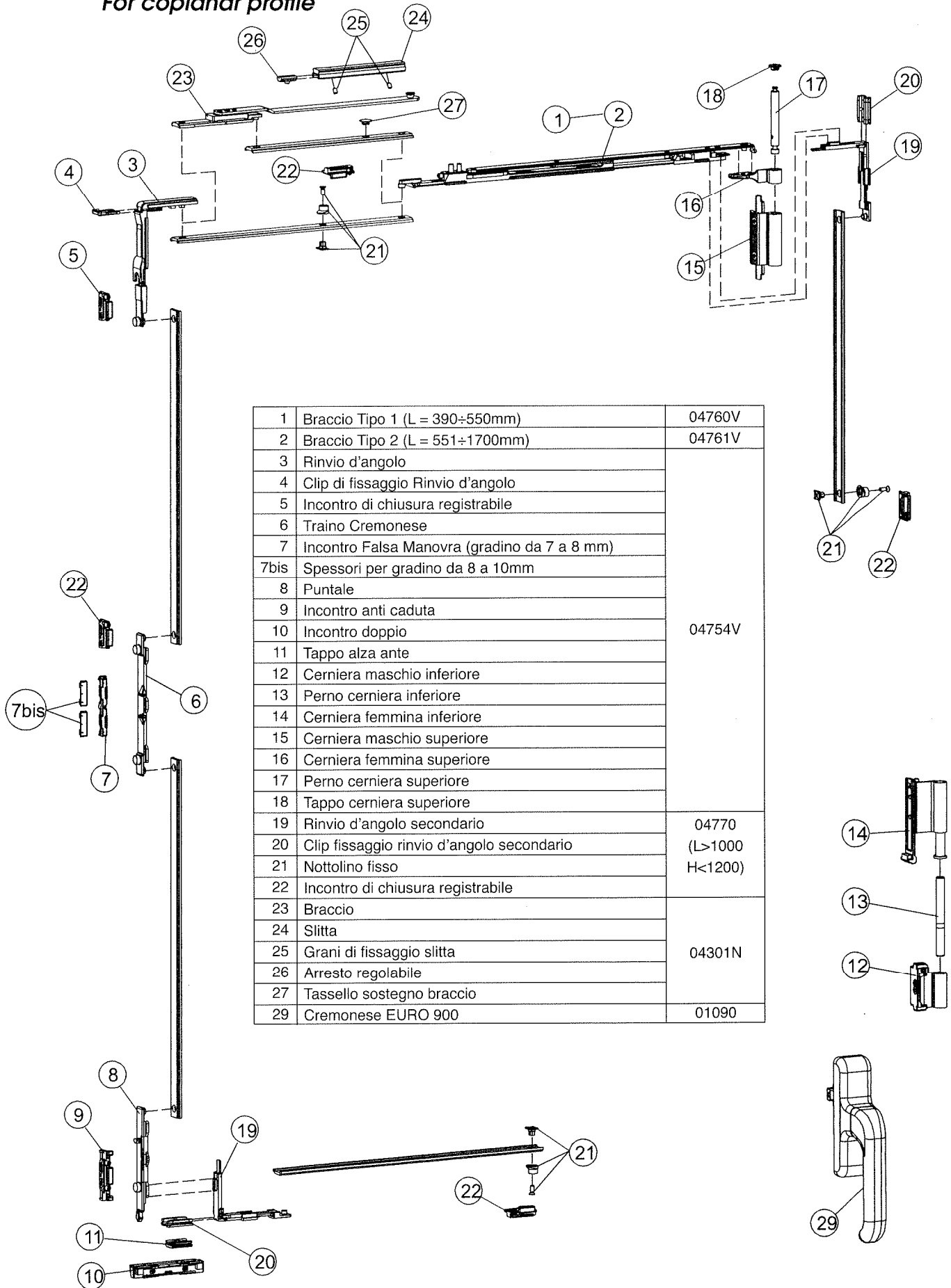
100-4574 Per profili complanari
For coplanar profile



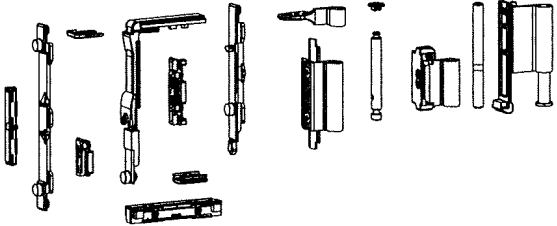

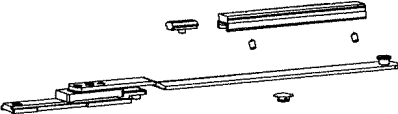
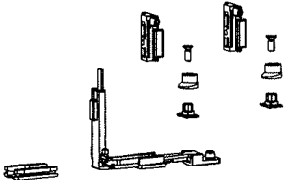
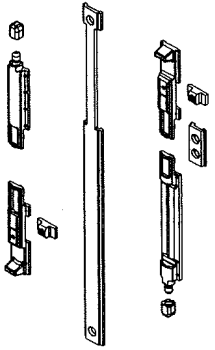
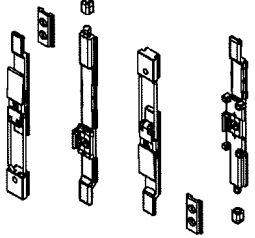









1	Braccio Tipo 1 (L = 390÷550mm)	04760V
2	Braccio Tipo 2 (L = 551÷1700mm)	04761V
3	Rinvio d'angolo	
4	Clip di fissaggio Rinvio d'angolo	
5	Incontro di chiusura registrabile	
6	Traino Cremonese	
7	Incontro Falsa Manovra (gradino da 7 a 8 mm)	
7bis	Spessori per gradino da 8 a 10mm	
8	Puntale	
9	Incontro anti caduta	
10	Incontro doppio	04754V
11	Tappo alza ante	
12	Cerniera maschio inferiore	
13	Perno cerniera inferiore	
14	Cerniera femmina inferiore	
15	Cerniera maschio superiore	
16	Cerniera femmina superiore	
17	Perno cerniera superiore	
18	Tappo cerniera superiore	
19	Rinvio d'angolo secondario	04770
20	Clip fissaggio rinvio d'angolo secondario	(L>1000 H<1200)
21	Nottolino fisso	
22	Incontro di chiusura registrabile	
23	Braccio	
24	Slitta	
25	Grani di fissaggio slitta	04301N
26	Arresto regolabile	
27	Tassello sostegno braccio	
29	Cremonese EURO 900	01090

	<p>MECCANISMO BASE ANTA RIBALTA FUTURA</p> <p>100-4754V Composto da tutta la ferramenta di scorrimento (rinvio, traino e puntale) dagli incontri da porre sul telaio e dalle cerniere (premontate).</p>
	<p>BRACCIO ANTA RIBALTA FUTURA</p> <p>100-4760V Braccio tipo 1 necessario da 390 a 550mm</p> <p>100-4761V Braccio tipo 2 necessario da 550 a 1700mm</p>
	<p>BRACCIO SUPPLEMENTARE ANTA RIBALTA FUTURA</p> <p>100-4301N</p>
	<p>CHIUSURA SUPPLEMENTARI ORIZZONTALI O VERTICALI PER ANTA RIBALTA FUTURA</p> <p>100-4770 Opportuno per la realizzazione di chiusure supplementari su ante con L > 1000mm e H > 1200mm (qualora fossero da realizzare sia alla chiusura verticale che quella orizzontale, saranno necessari due pezzi)</p>
	<p>CATENACCIO GIAP PER ANTA ABBINATA AD ANTA RIBALTA FUTURA</p> <p>100-4274 Catenaccio per anta abbinata caratterizzato dai terminali con corpo in nylon e perno di chiusura in acciaio dotato di boccola con cui è possibile regolare la compressione in battuta.</p> <p>Manovra a scatto.</p>
	<p>CATENACCIO INCA PER ANTA ABBINATA AD ANTA RIBALTA FUTURA</p> <p>100-4282 Catenaccio per anta abbinata caratterizzato dai termini in zama su cui sono già premontati gli incontri di chiusura regolabili.</p> <p>Manovra a leva.</p>

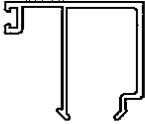
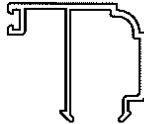
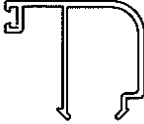
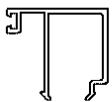
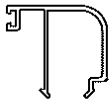
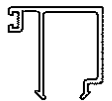
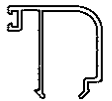
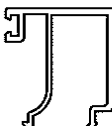
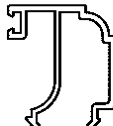
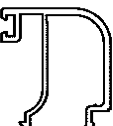
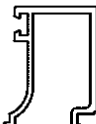
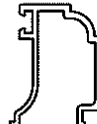
N.B.: Per lavorazioni e montaggio seguire le istruzioni del foglio illustrativo inserito nel kit.

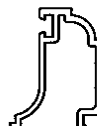
For tooling and mounting follow the instructions leaflet in the kit.

ARTICOLO ITEM	MATERIALE MATERIAL	DESCRIZIONE DESCRIPTION	ARTICOLO ITEM	MATERIALE MATERIAL	DESCRIZIONE DESCRIPTION
102-6196	ALFAPRENE	GUARNIZIONE DISTANZIATRICE E SUPPORTO SIGILLATURA VETRI SPACING GASKET AND GLASS SEALING SUPPORT	126-2972	EPDM	GUARNIZIONE DI VETRAZIONE INTERNA SPESSORE mm 3 3 mm THICK, INTERNAL GLASS BEADING GASKET
102-6197	ALFAPRENE	GUARNIZIONE DI BATTUTE PER PORTE INTERNE RABBET GASKET FOR INTERNAL DOORS	126-3851	SANTOPRENE	GUARNIZIONE DI BATTUTA INTERNA INTERNAL RABBET GASKET
103-98135	EPDM	GUARNIZIONE PER GIUNTI A NASTRO RIBBON JOINT GASKET	126-1851	COPLENE COESTRUSO	
126-0978	COPLENE	GUARNIZIONE DI FINITURA PER PORTE INTERNE FINISHING GASKET FOR INTERNAL DOORS	126-4147	EPDM	ANGOLO VULCANIZZATO PER GUARNIZIONE 126-2261 VULCANIZED ANGLE FOR GASKET 126-2261
126-1074	COPLENE COESTRUSO	GUARNIZIONE FERMAVETRO INTERNA mm 2,5 INTERNAL GLASS BEADING GASKET 2,5 mm	619-PB79 619-PB59	(7x9) (5x9)	TENUTA PORTE E MONOBLOCCO DOOR AND MONOBLOCK SEAL
126-1205	PVC COESTRUSO	GUARNIZIONE DI SUPPORTO SIGILLATURA VETRI SPESSORE mm 4 mm. 4 THICK SUPPORT GLASS SEAL GASKET			
126-1539	PVC COESTRUSO	GUARNIZIONE DI SUPPORTO OVALINE SLAT SUPPORT GASKET			
126-1845	COPLENE COESTRUSO	GUARNIZIONE FERMAVETRO INTERNA mm 1,5 INTERNAL GLASS BEADING GASKET 1,5 mm			
126-2178	EPDM	GUARNIZIONE DI VETRAZIONE ESTERNA SPESSORE mm 2,5 2,5 mm THICK EXTERNAL GLASS BEADING GASKET			
126-2194	EPDM	GUARNIZIONE DI VETRAZIONE ESTERNA SPESSORE mm 3/4 3/4 mm THICK EXTERNAL GLASS BEADING GASKET			
126-2195	EPDM	GUARNIZIONE DI VETRAZIONE ESTERNA SPESSORE mm 5/6 5/6 mm THICK EXTERNAL GLASS BEADING GASKET			
126-2197	EPDM	GUARNIZIONE DI VETRAZIONE ESTERNA SPESSORE mm 7/8 7/8 mm THICK EXTERNAL GLASS BEADING GASKET			
126-2261	EPDM	GUARNIZIONE DI TENUTA CENTRALE A GIUNTO APERTO OPEN JOINT, CENTRAL SEAL			
126-2284	EPDM	GUARNIZIONE DI APPOCCIO SOGLIA THRESHOLD BEARINGS GASKET			
126-2340	EPDM	GUARNIZIONE DI GIUNZIONE PER TELAI FRAME SEAL			
126-2341	EPDM	GUARNIZIONE DI TENUTA A MURO FLOOR THRESHOLD GASKET			
126-2429	EPDM SEMIRIGIDO	GUARNIZIONE COPRICAVA FERMAVETRO GLASS BEADING COVER CAVITY GASKET			
126-2666	EPDM	GUARNIZIONE DI BATTUTA INTERNA INTERNAL JOINT GASKET			
126-2800	EPDM	GUARNIZIONE DI VETRAZIONE INTERNA SPESSORE mm 2 2 mm THICK, INTERNAL GLASS BEADING GASKET			

126-2178		126-2800		126-2194		126-2195		126-2197		126-2972		
												
A=3 mm		B=2 mm		C=3÷4 mm		D=5÷6 mm		E=7÷8 mm		F=3 mm (*) VARIANTE C		
SPESSORI VETRI mm GLASS THICKNESS mm	GUARNIZIONI GASKETS	DIMENSIONI FERMAVETRI GLASS BEADING DIMENSIONS mm		PROFILI E SEZIONI FERMAVETRI GLASS BEADING PROFILES								
4 5	A+C *(F) A+B	31										
				4297			16307		4196			
6	A+C *(F)	29										
				9040		9041						
7 8	A+C *(F) A+C *(F)	27										
				11084		16808						
9 10 11 12 13	A+D A+D A+C *(F) A+C *(F) A+B	23										
				4298			11202		4195			
14 16 16 17 18 19	A+E A+D A+D A+C *(F) A+C *(F) A+B	17										
				4296			14371		4299			
20 21 22 23	A+D A+C *(F) A+C *(F) A+B	13										
				4294			11203		4295			
24 25	A+C *(F) A+C *(F)	10										
							9159					
26 27 28 29 30 31 32	A+E A+E A+D A+D A+C A+C A+B	4										
							4293					

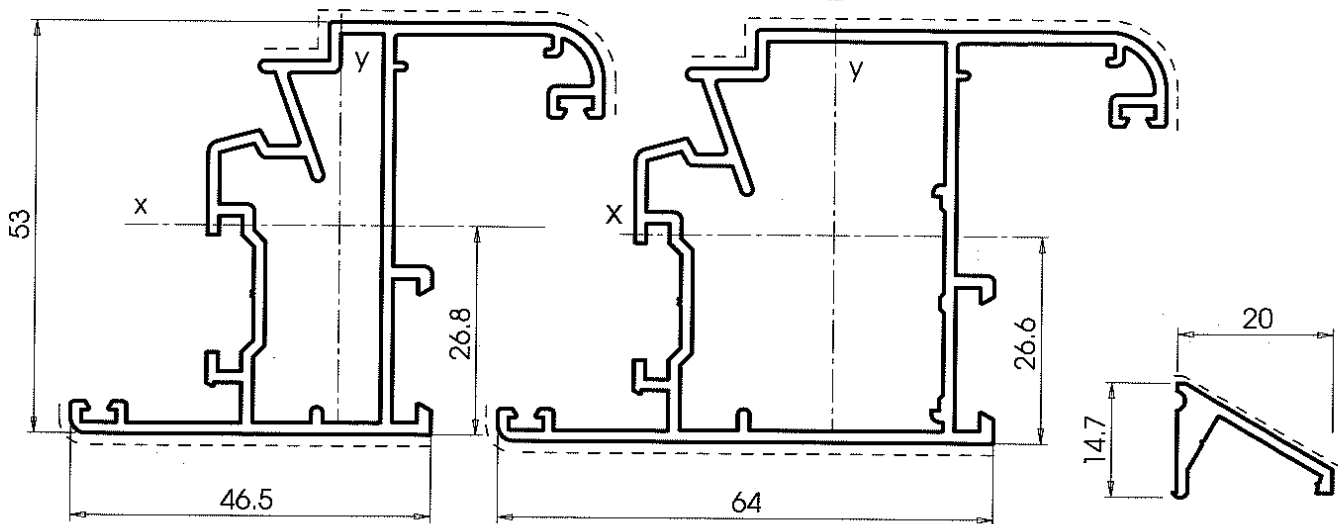

4265

peso: Kg./mt. 1.050
sup. vista: mm. 112
Jx cm⁴: 14.3

4273

peso: Kg./mt. 1.215
sup. vista: mm. 138
Jx cm⁴: 17.98

5767

peso: Kg./mt. 0.190
sup. vista: mm. 23

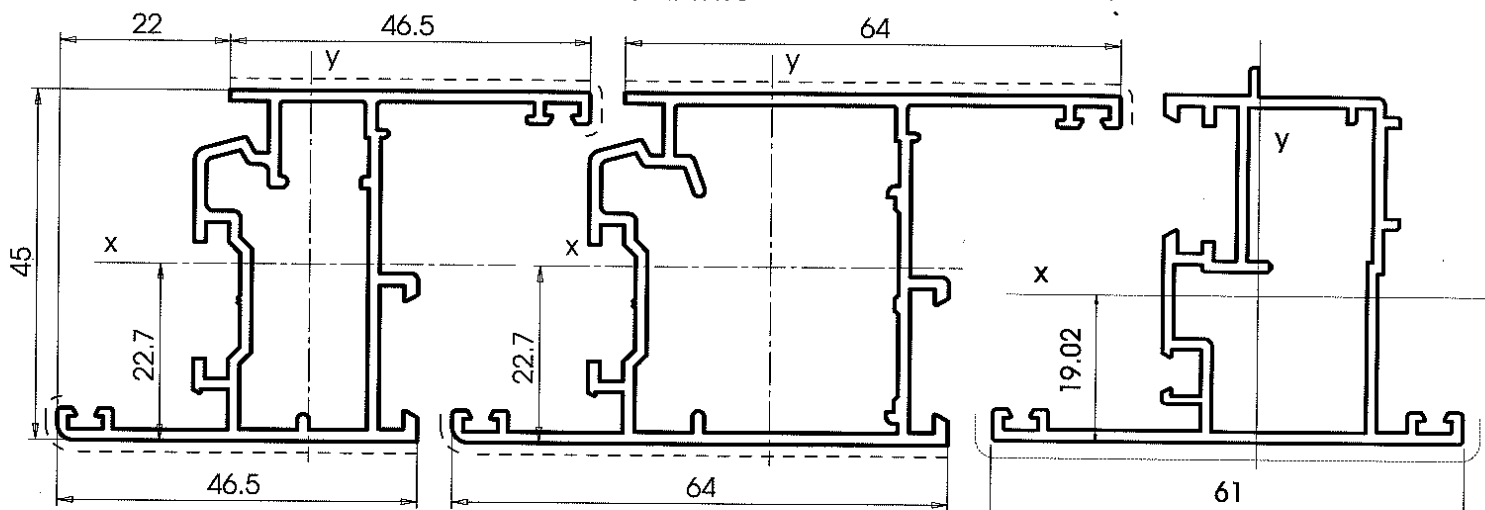

4198

peso: Kg./mt. 0.926
sup. vista: mm. 101
Jx cm⁴: 9.9

4199

peso: Kg./mt. 1.098
sup. vista: mm. 136
Jx cm⁴: 12.6

4263

peso: Kg./mt. 0.885
sup. vista: mm. 68
Jx cm⁴: 9,22

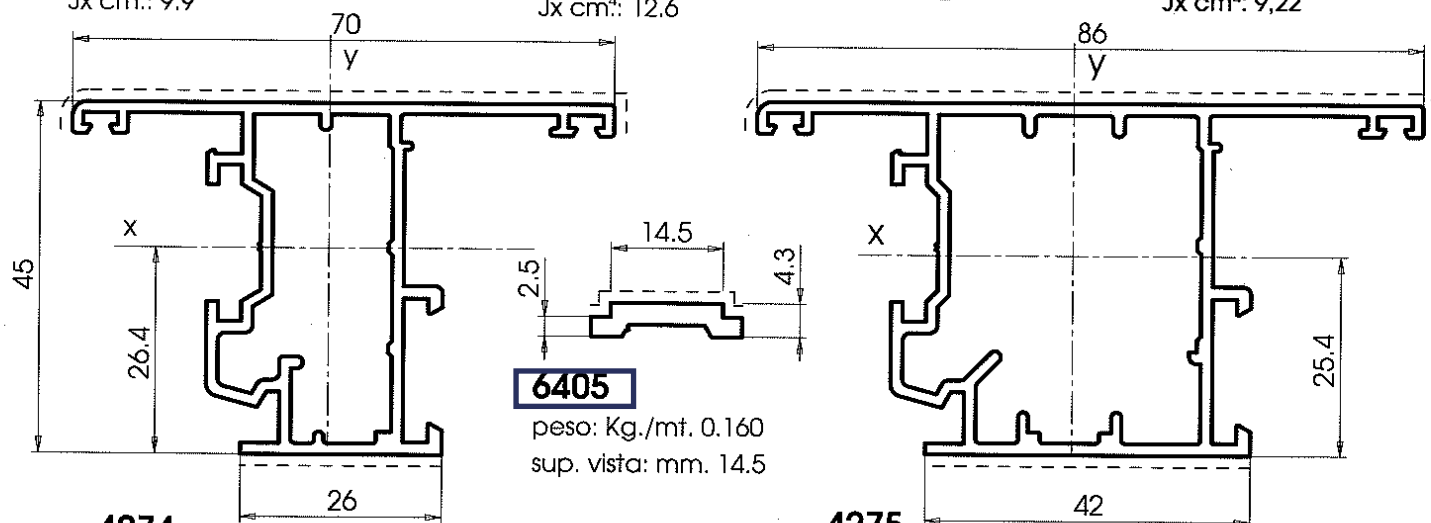

4274

peso: Kg./mt. 955
sup. vista: mm. 104
Jx cm⁴: 9.75

6405

peso: Kg./mt. 0.160
sup. vista: mm. 14.5

4275

peso: Kg./mt. 1.135
sup. vista: mm. 136
Jx cm⁴: 12.8

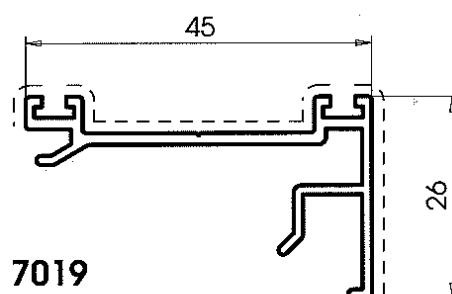
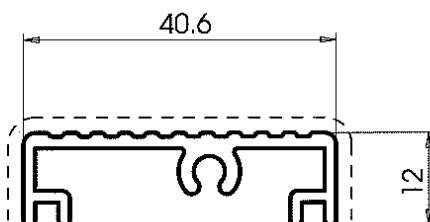
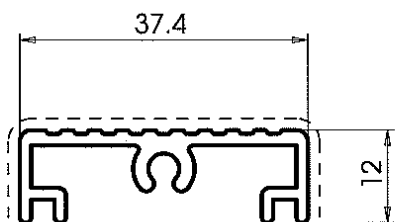
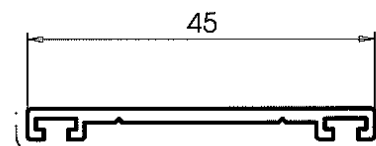
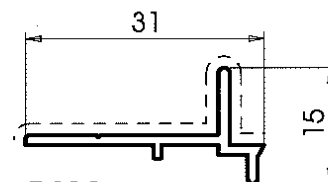
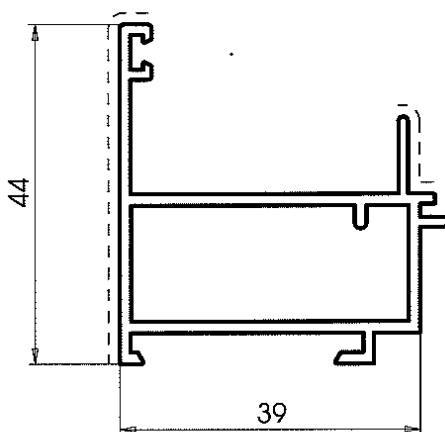
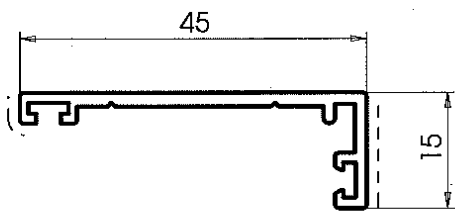
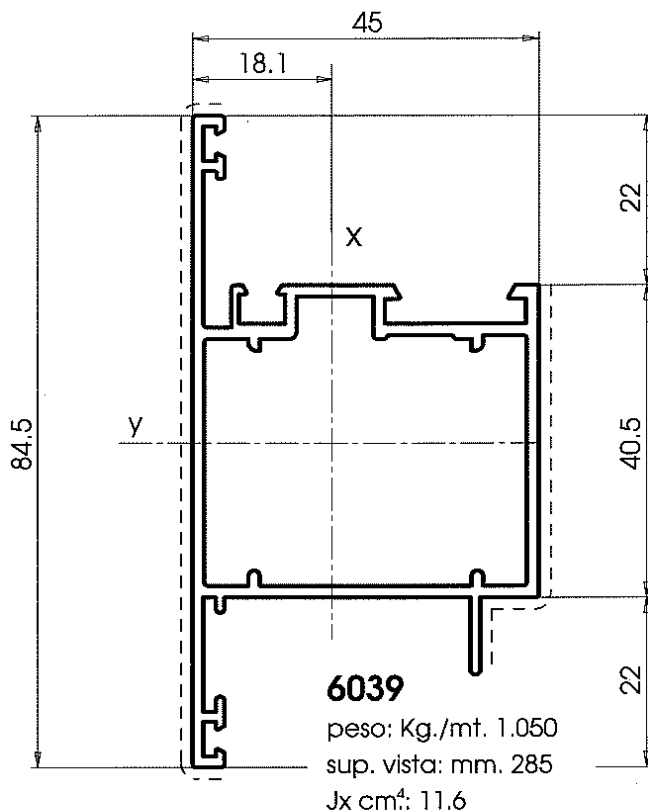
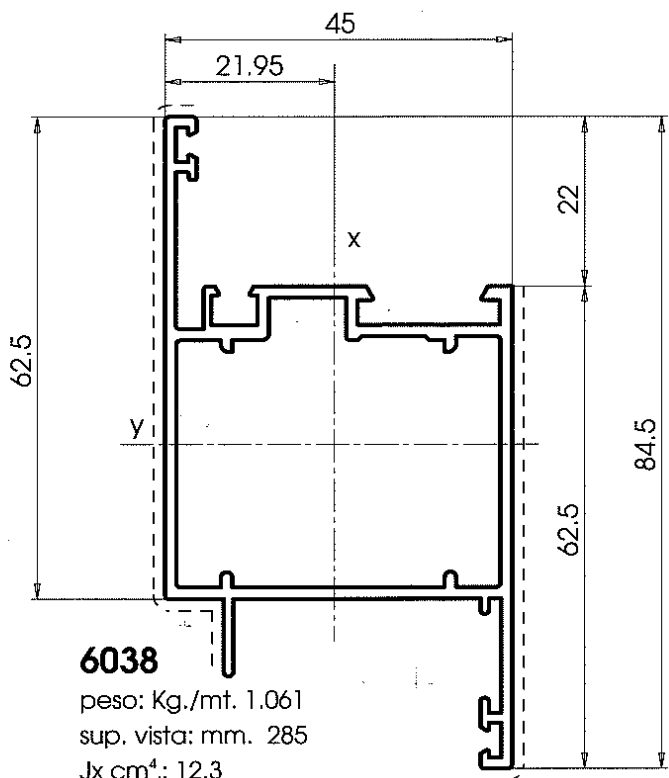

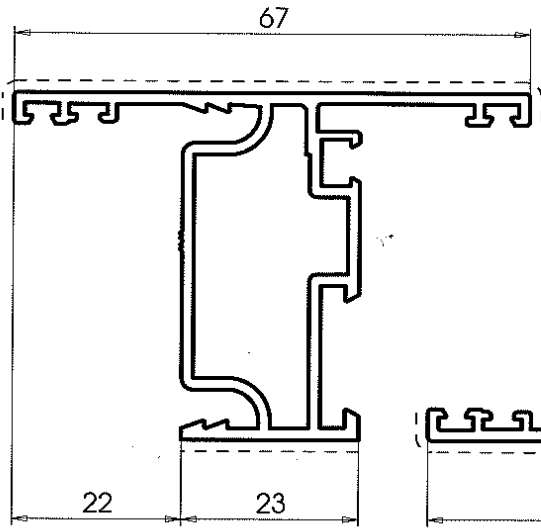

4262

peso: Kg./mt. 0.922
sup. vista: mm. 98

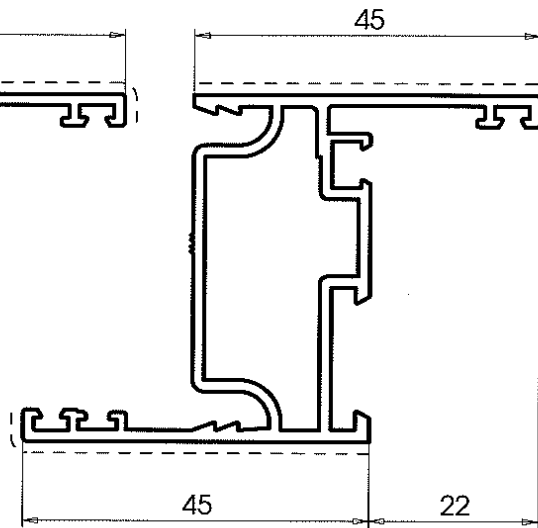

4260

peso: Kg./mt. 0.922
sup. vista: mm. 98

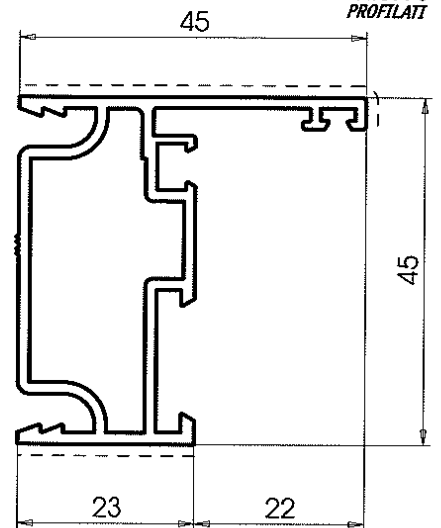

4261

peso: Kg./mt. 0.795
sup. vista: mm. 72

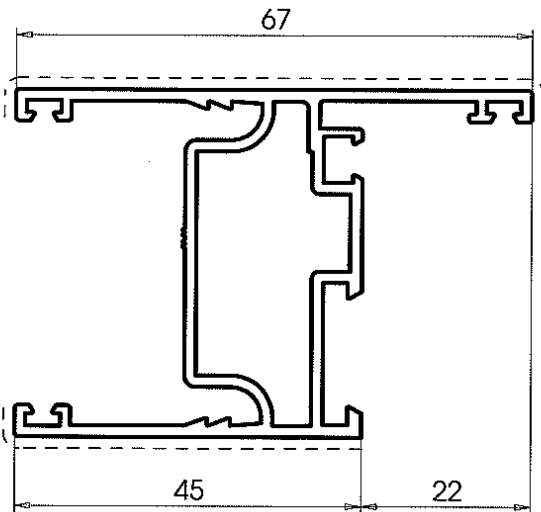

4270

peso: Kg./mt. 1.021
sup. vista: mm. 125

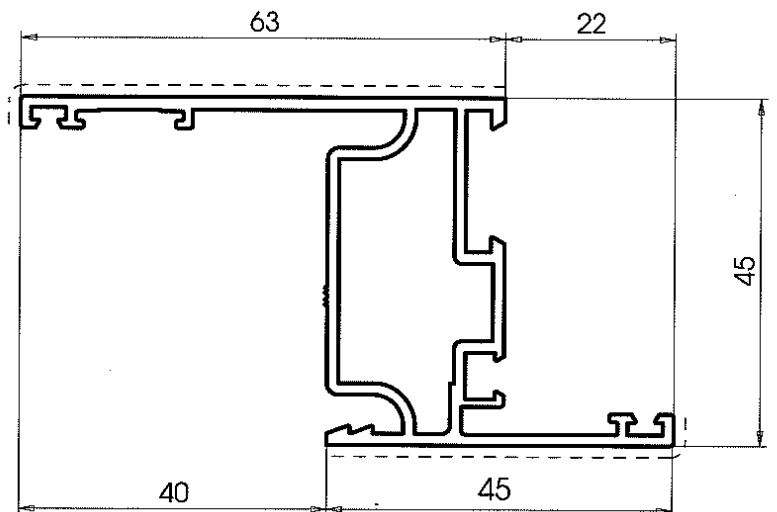

5682

peso: Kg./mt. 1.011
sup. vista: mm. 118

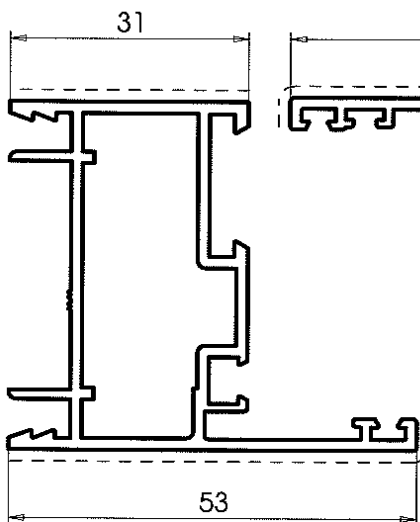

7011

peso: Kg./mt. 0.861
sup. vista: mm. 88

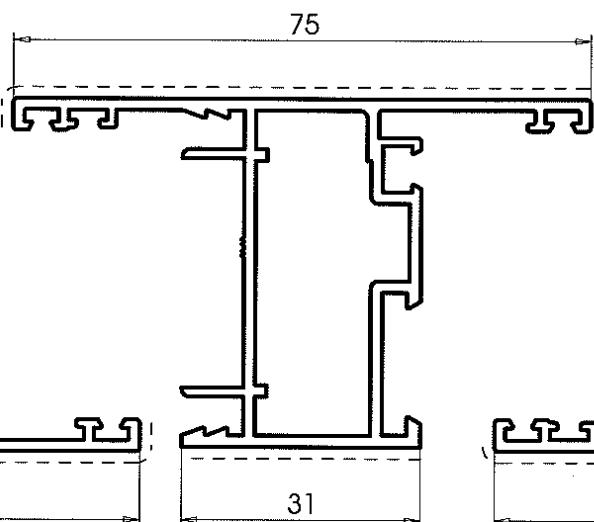

7013

peso: Kg./mt. 0.986
sup. vista: mm. 114

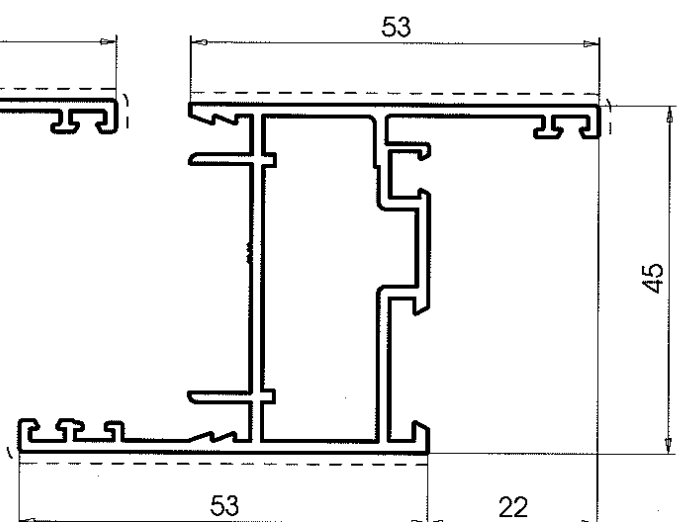

7012

peso: Kg./mt. 0.986
sup. vista: mm. 114

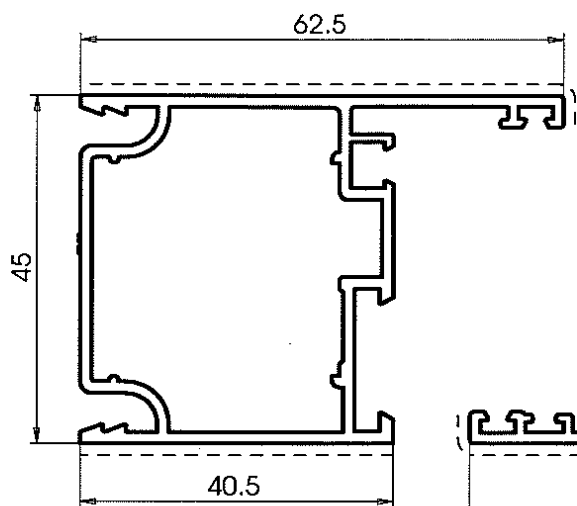

4267

peso: Kg./mt. 0.964
sup. vista: mm. 108

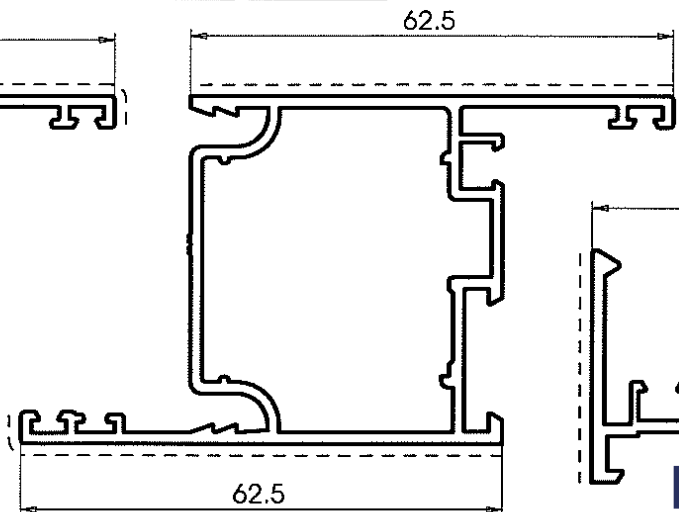

4266

peso: Kg./mt. 1.088
sup. vista: mm. 133

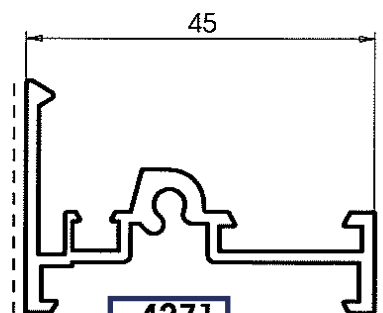

4271

peso: Kg./mt. 0.553
sup. vista: mm. 43

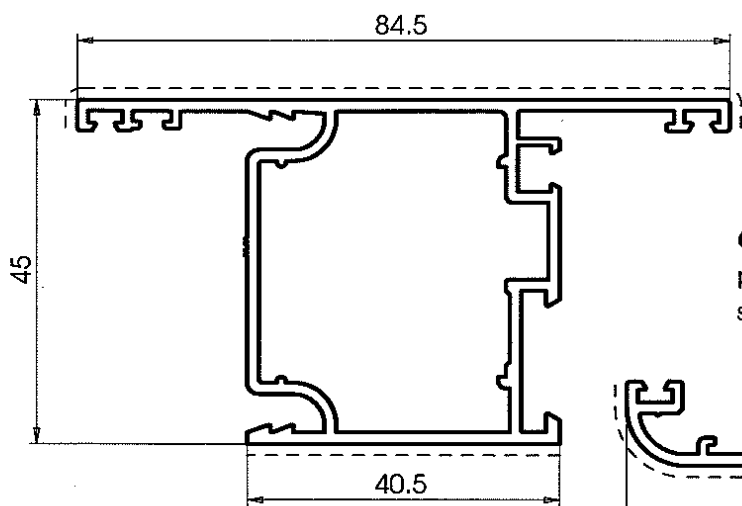

4268

peso: Kg./mt. 1.088
sup. vista: mm. 133

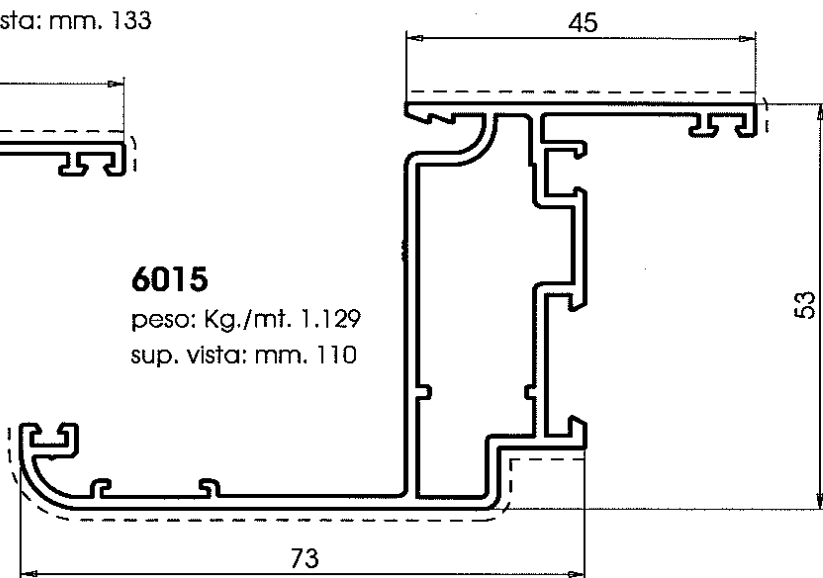

6015

peso: Kg./mt. 1.129
sup. vista: mm. 110

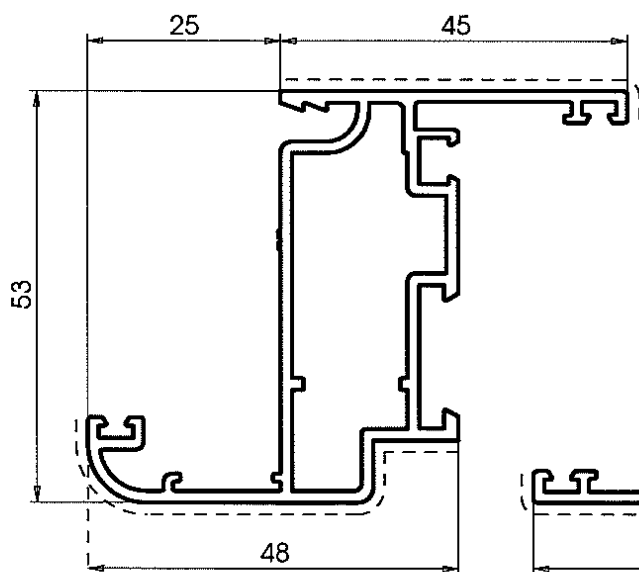

4200

peso: Kg./mt. 1.005
sup. vista: mm. 113

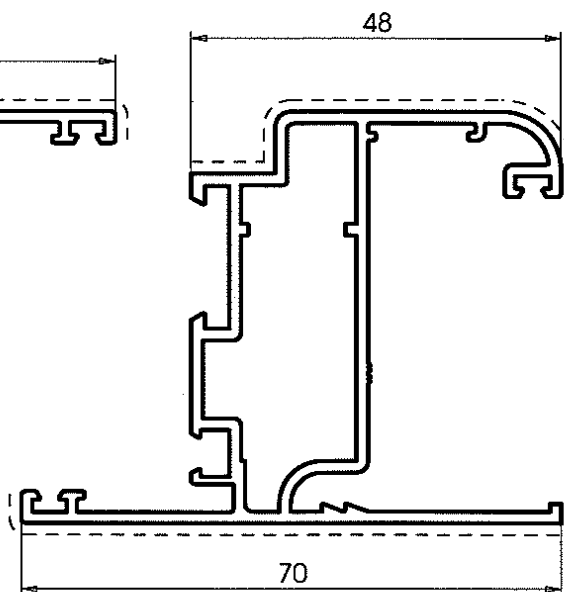

4201

peso: Kg./mt. 1.110
sup. vista: mm. 140

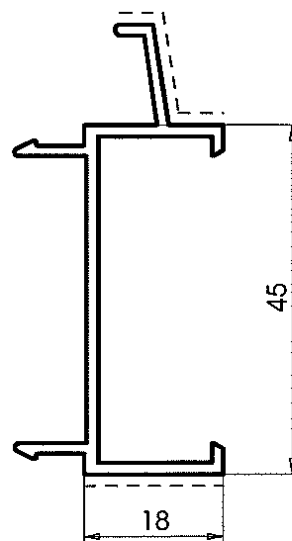

4289

peso: Kg./mt. 0.465
sup. vista: mm. 41

Note: = Profili po narudžbi

= Profili na stanju u Sarajevu

* Ostali profili su na redovnom lageru u Bolonji

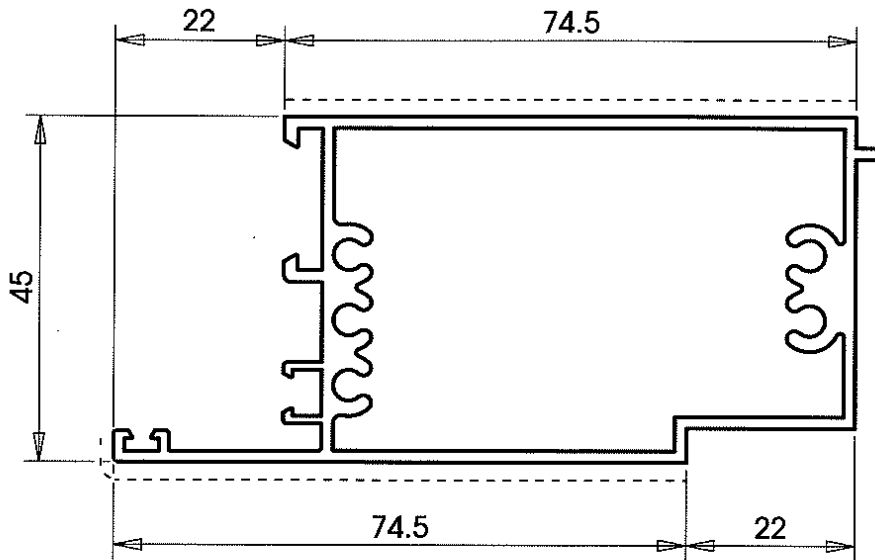

4286

peso: Kg./mt. 1.525
 sup. vista: mm. 152

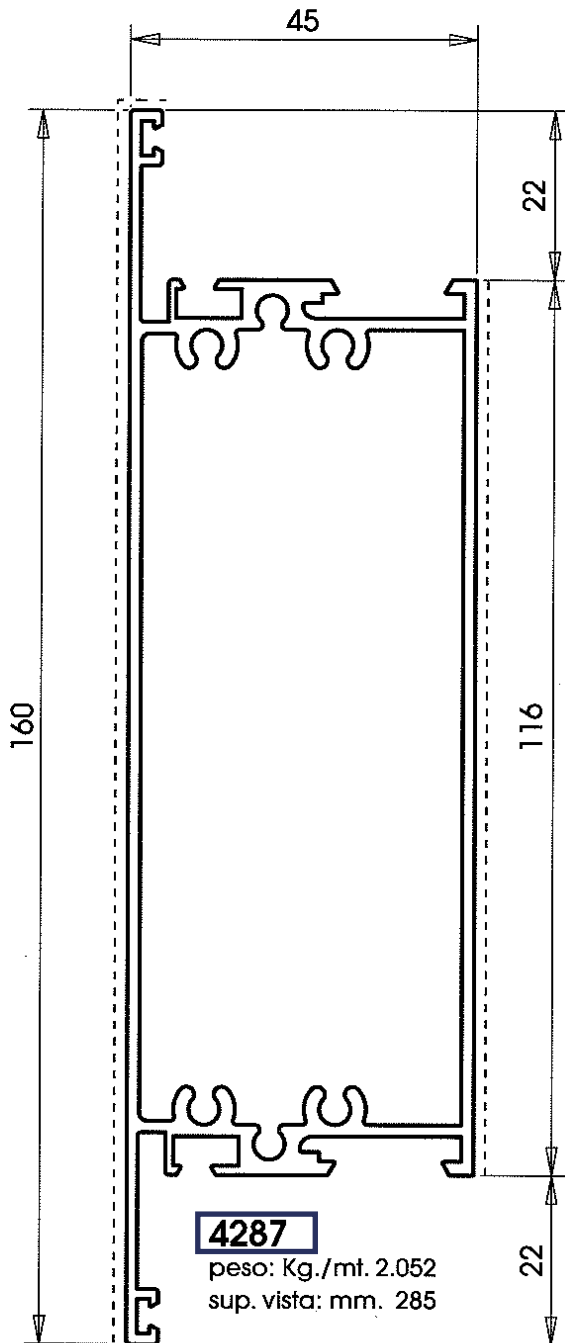

4287

peso: Kg./mt. 2.052
 sup. vista: mm. 285

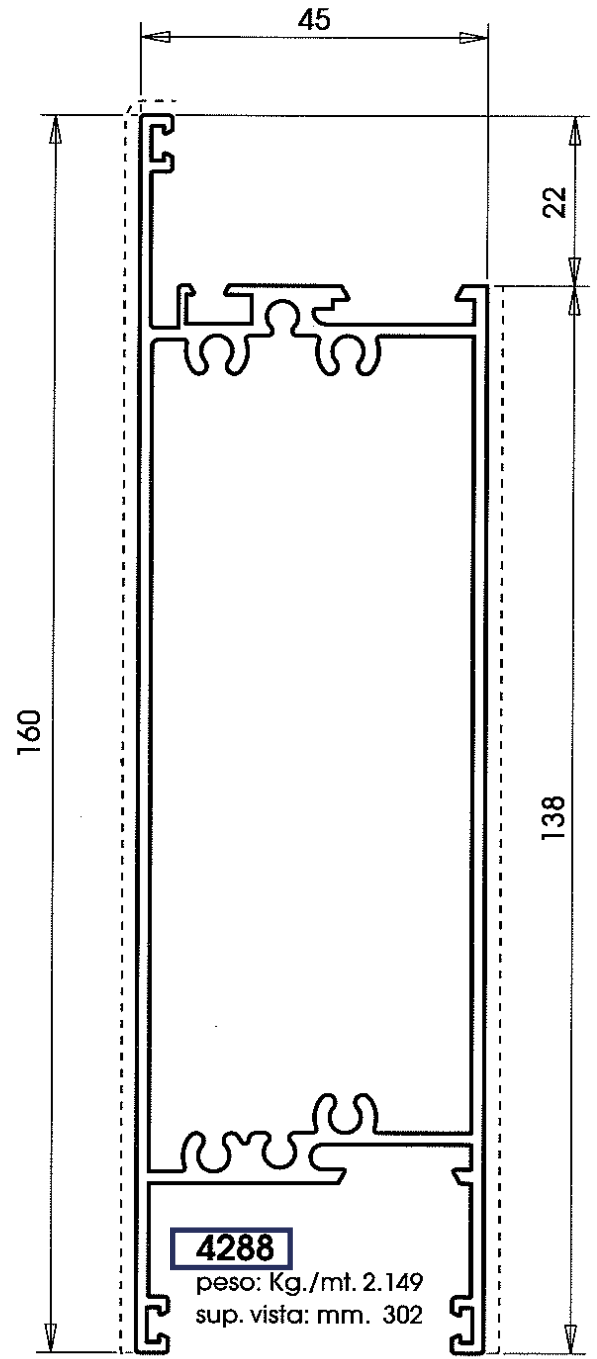

4288

peso: Kg./mt. 2.149
 sup. vista: mm. 302

Note: = Profili po narudžbi

= Profili na stanju u Sarajevu

* Ostali profili su na redovnom lageru u Bolonji

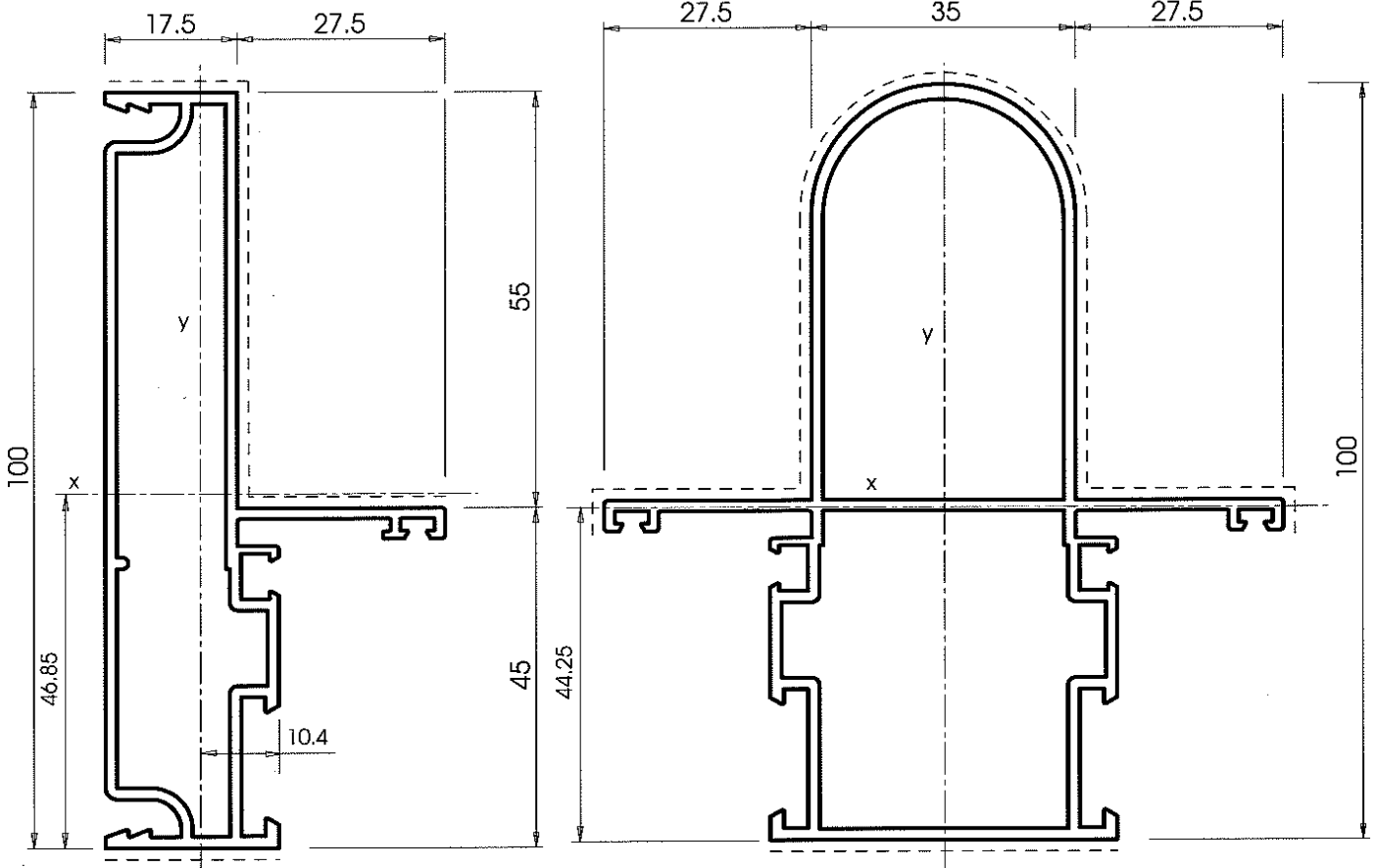

4283

peso: Kg./mt. 1.300
sup. vista: mm. 123
Jx cm⁴:45.1

4282

peso: Kg./mt. 1.631
sup. vista: mm. 238
Jx cm⁴:52.5

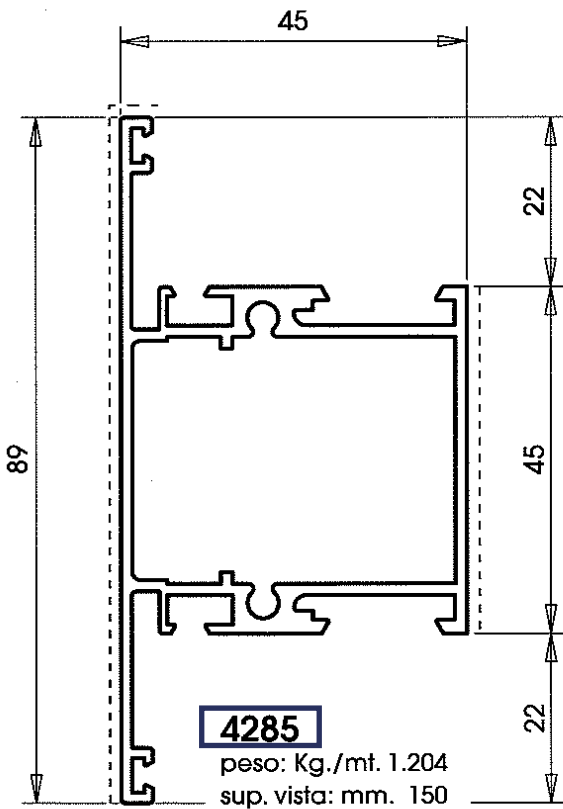

4285

peso: Kg./mt. 1.204
sup. vista: mm. 150

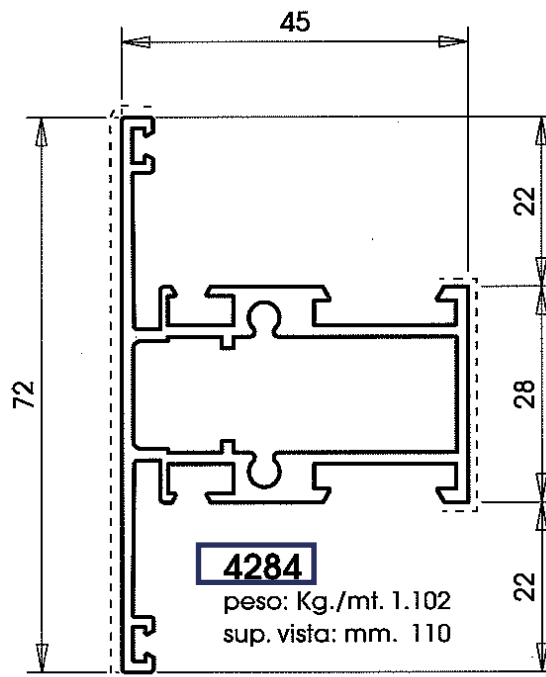

4284

peso: Kg./mt. 1.102
sup. vista: mm. 110

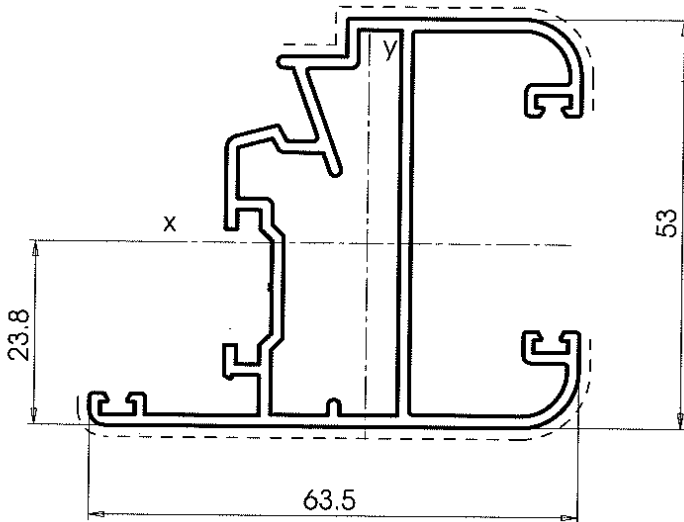

4264

peso: Kg./mt. 1.114
 sup. vista: mm. 127
 Jx cm.: 15.3

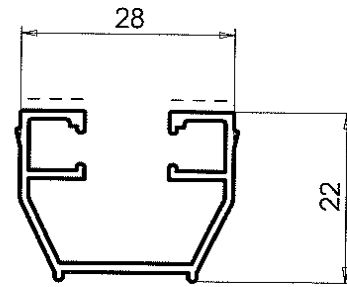

5683

peso: Kg./mt. 0.297
 sup. vista: mm. 17

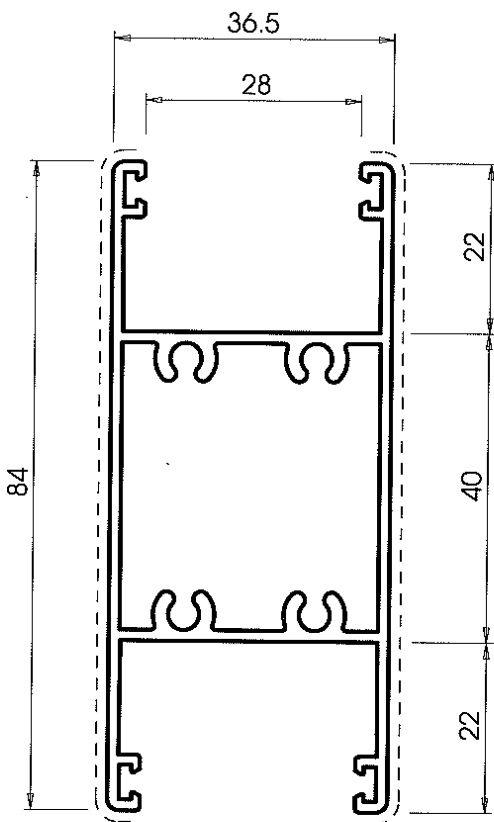

4276

peso: Kg./mt. 1.224
 sup. vista: mm. 185

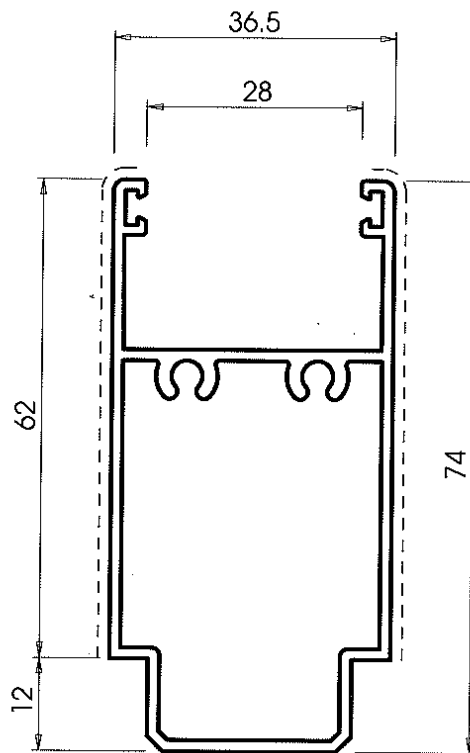

4278

peso: Kg./mt. 0.985
 sup. vista: mm. 130

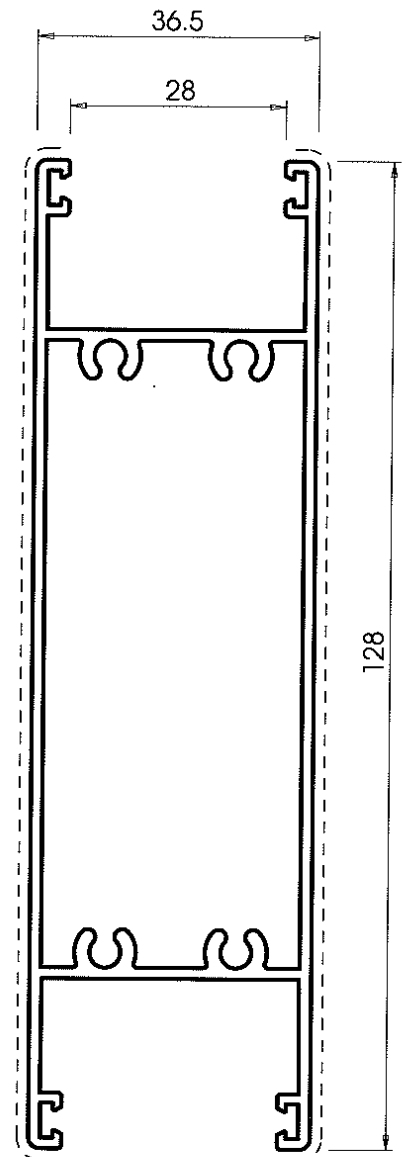

4277

peso: Kg./mt. 1.616
 sup. vista: mm. 272

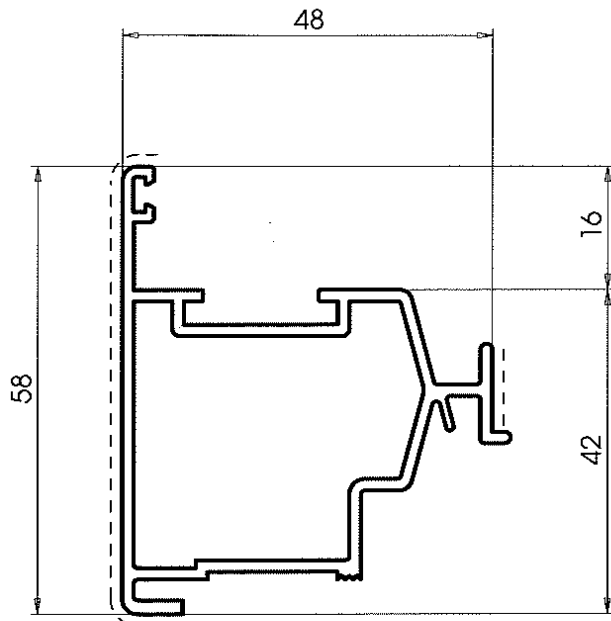

4280

peso: Kg./mt. 0.875
 sup. vista: mm. 74

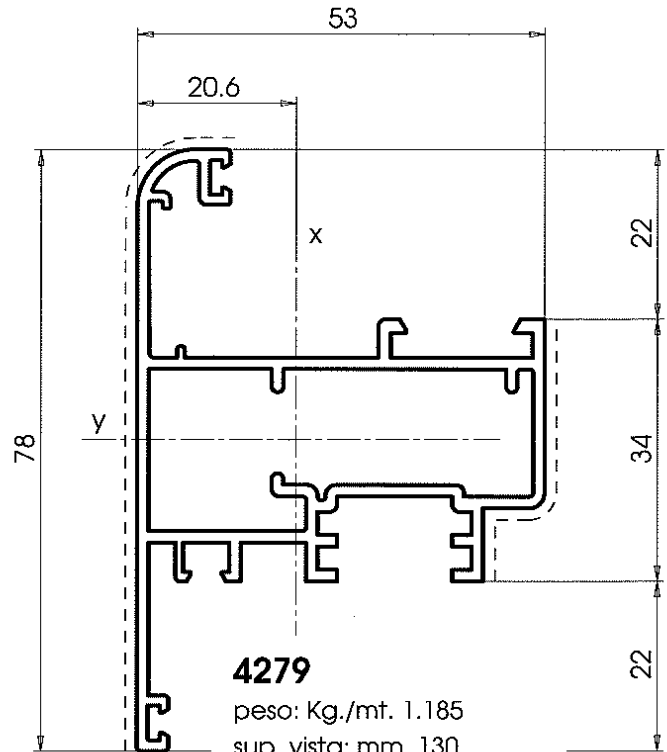

4279

peso: Kg./mt. 1.185
 sup. vista: mm. 130
 Jx cm⁴: 14.9

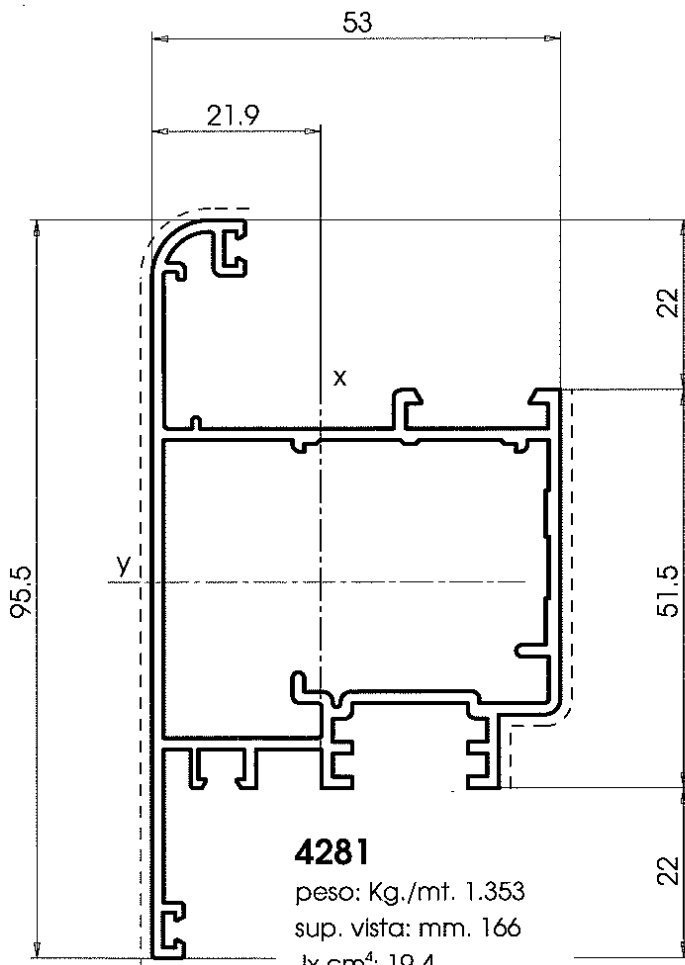

4281

peso: Kg./mt. 1.353
 sup. vista: mm. 166
 Jx cm⁴: 19.4

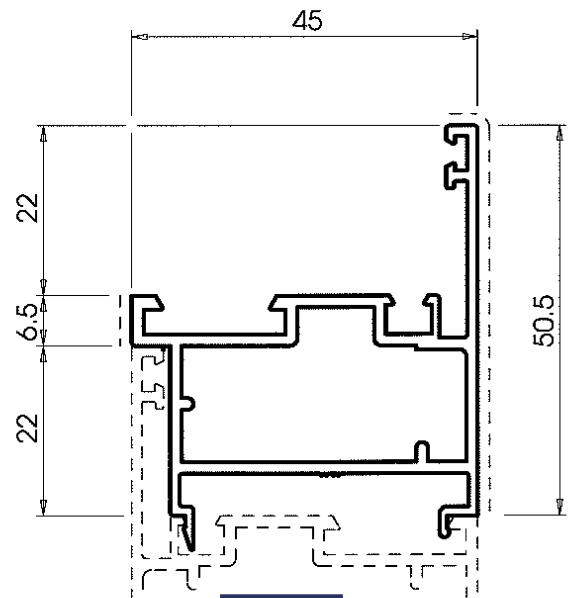

4272

peso: Kg./mt. 0.781
 sup. vista: mm. 62

INVERSIONE DI BATTUTA SPORGERE
INVERSION OF RABBET FOR
PROJECTING WINDOW

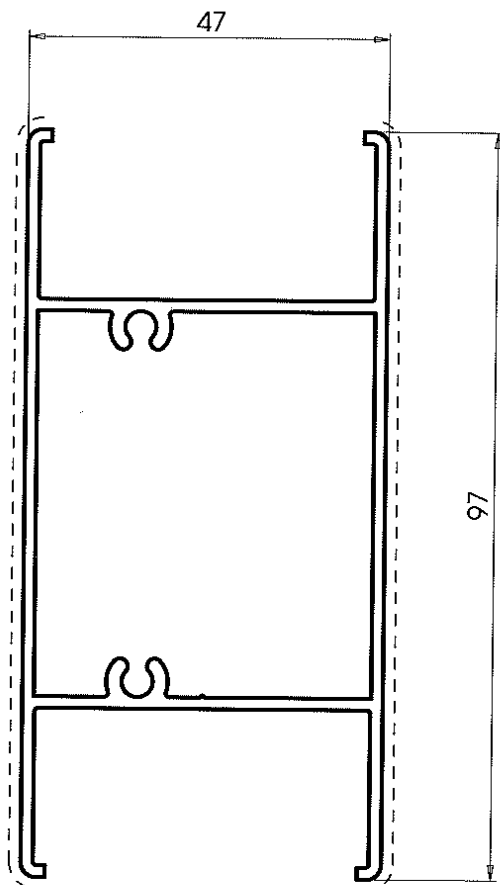

6018

peso: Kg./mt. 1.296
 sup. vista: mm. 203

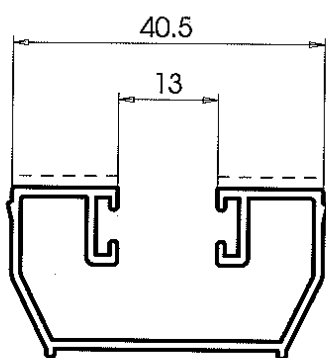

6020

peso: Kg./mt. 0.421
 sup. vista: mm. 26

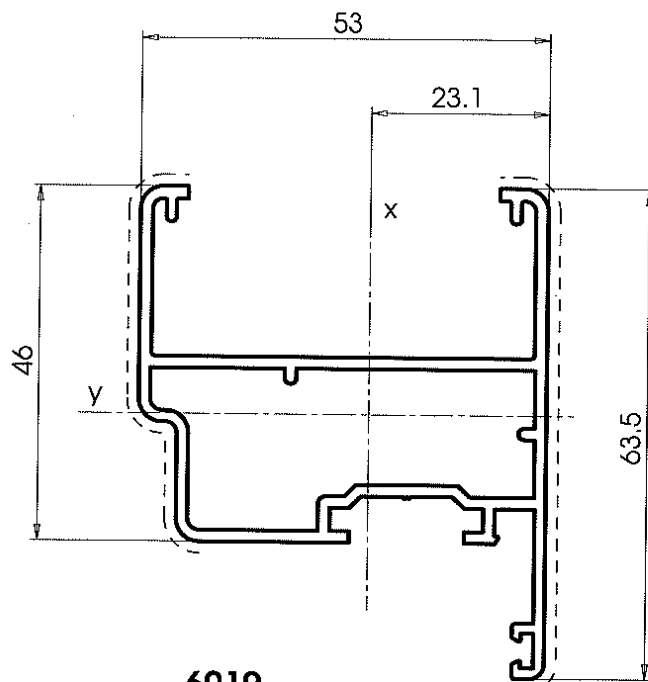

6019

peso: Kg./mt. 0.994
 sup. vista: mm. 127
 Jx cm⁴: 14.9

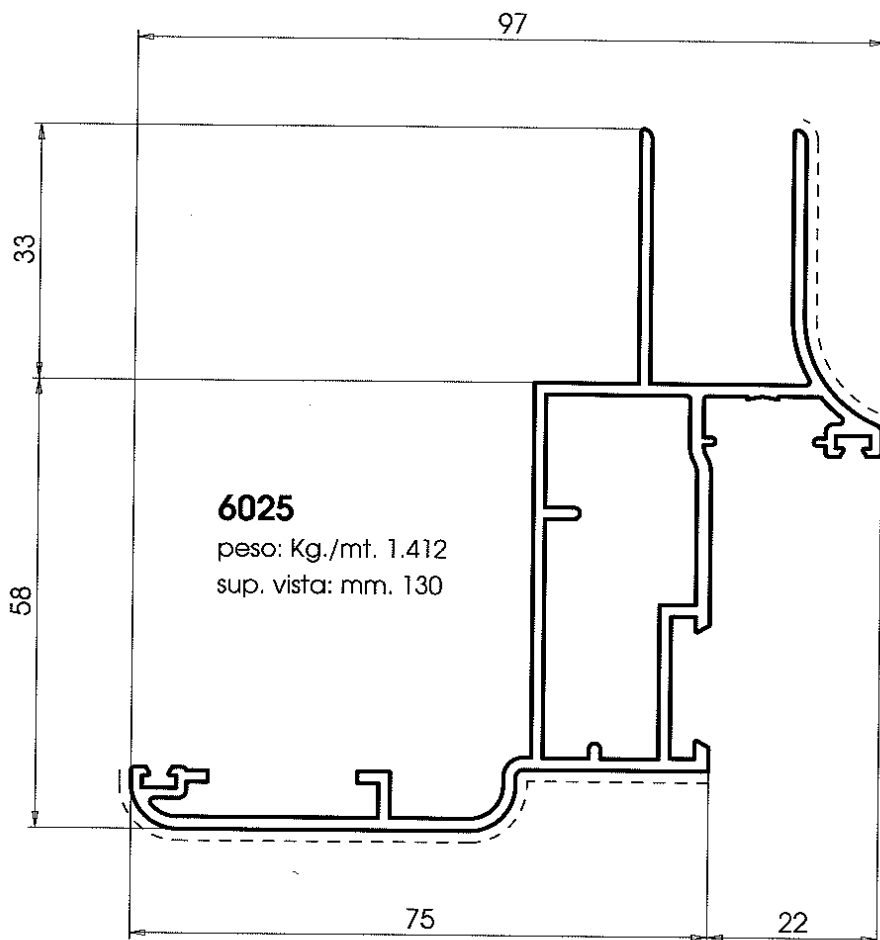

6025

peso: Kg./mt. 1.412
 sup. vista: mm. 130

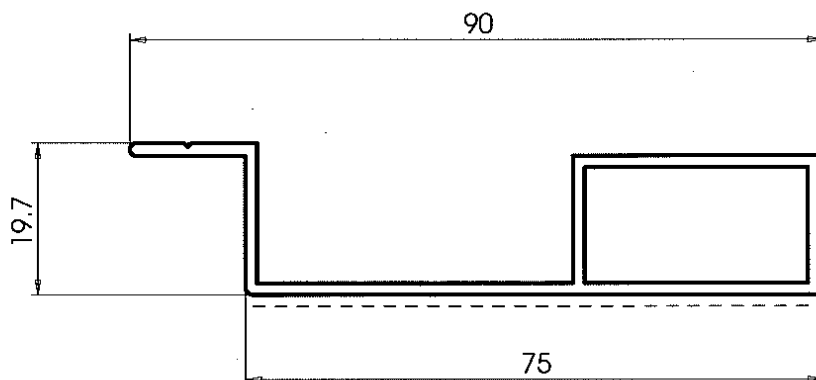
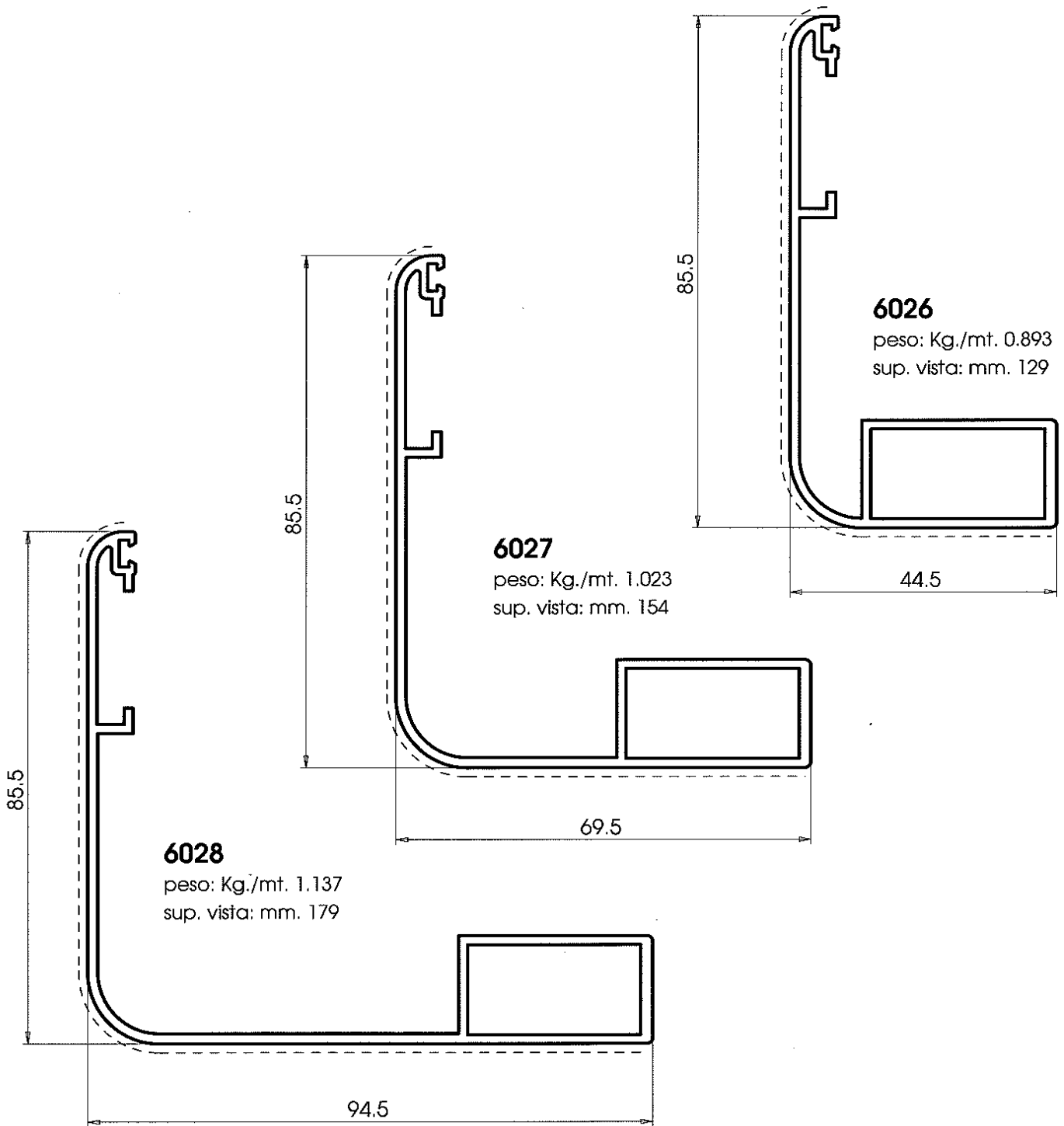

Note:  = Profili po narudžbi

 = Profili na stanju u Sarajevu

* Ostali profili su na redovnom lageru u Bolonji

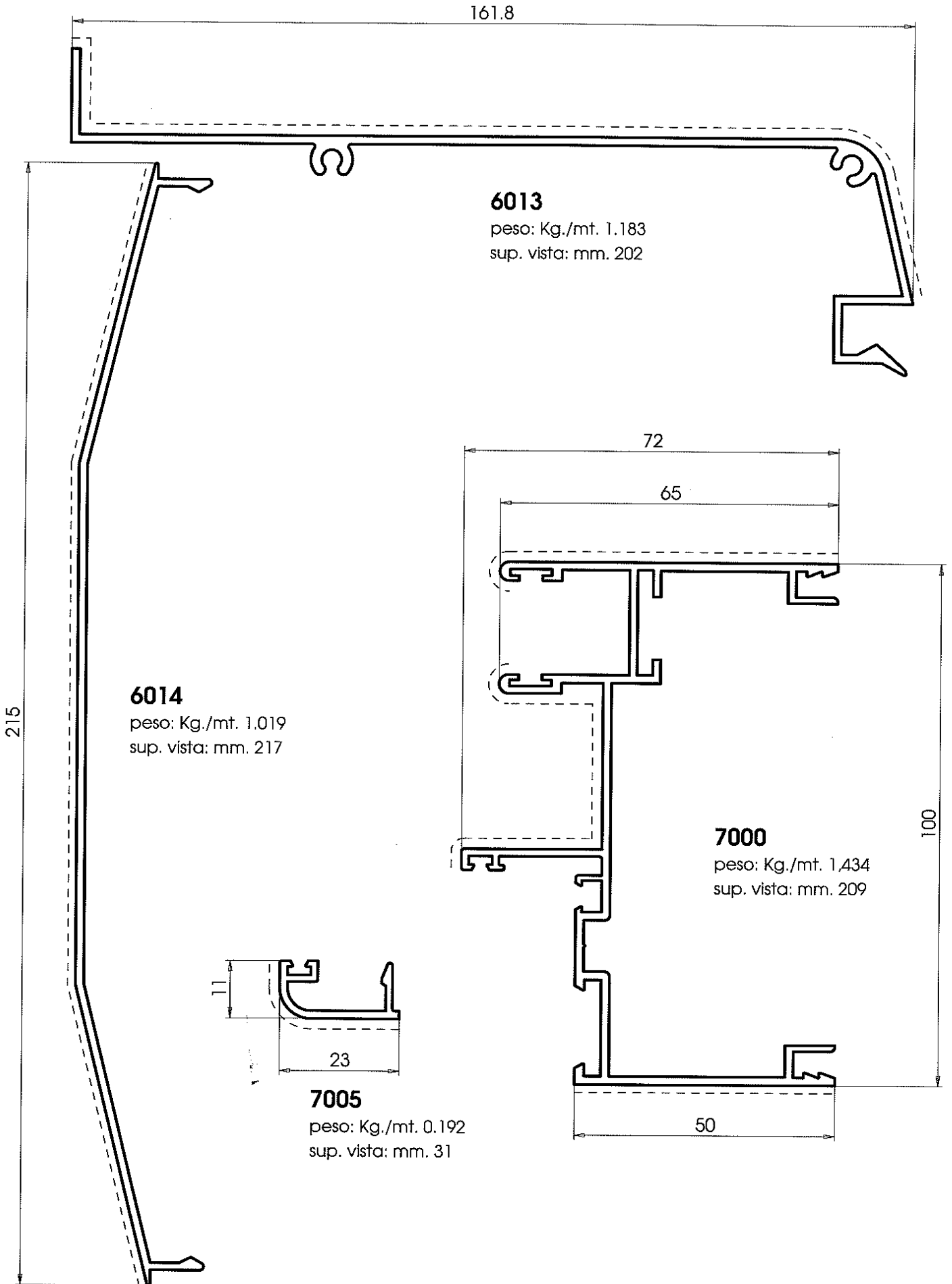

Note: = Profili per narudžbi

= Profili na stanju u Sarajevu

* Ostali profili su na redovnom lageru u Bolonji

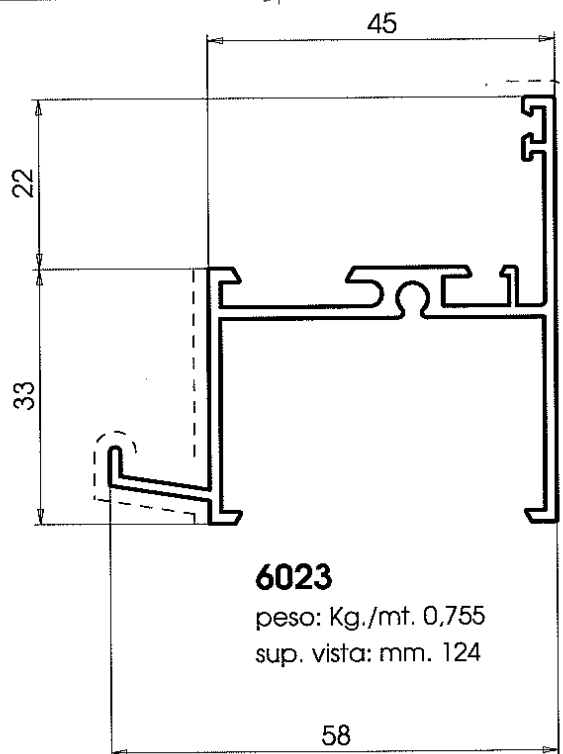
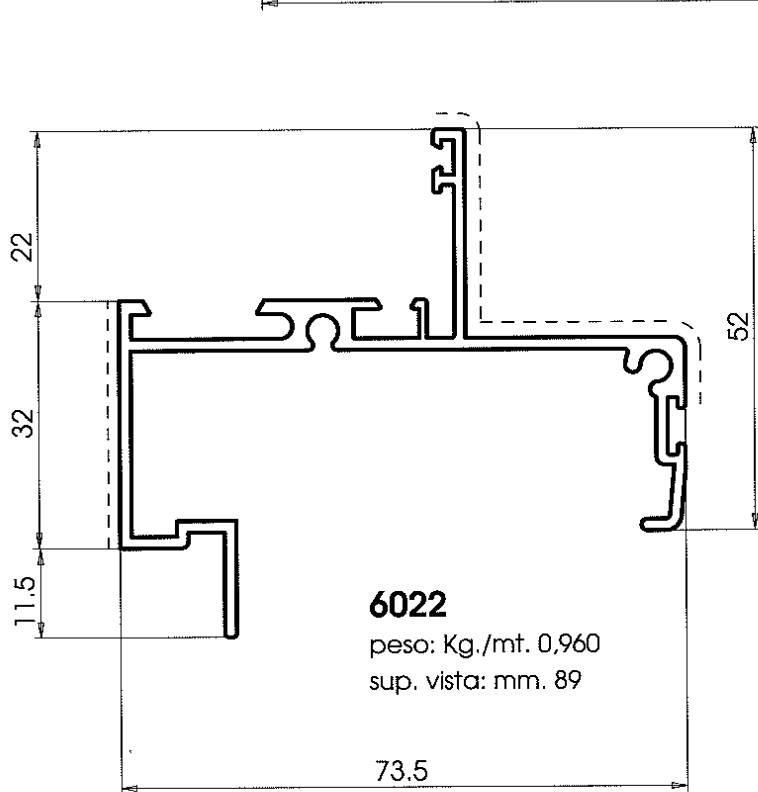
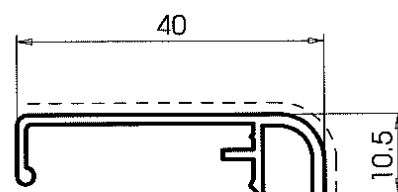
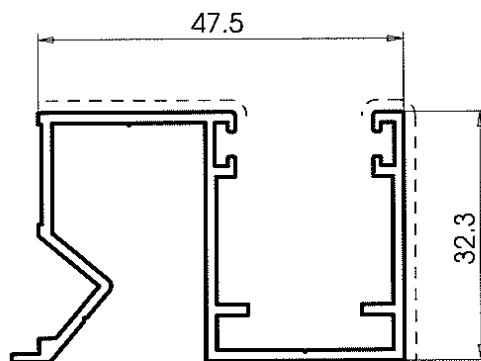
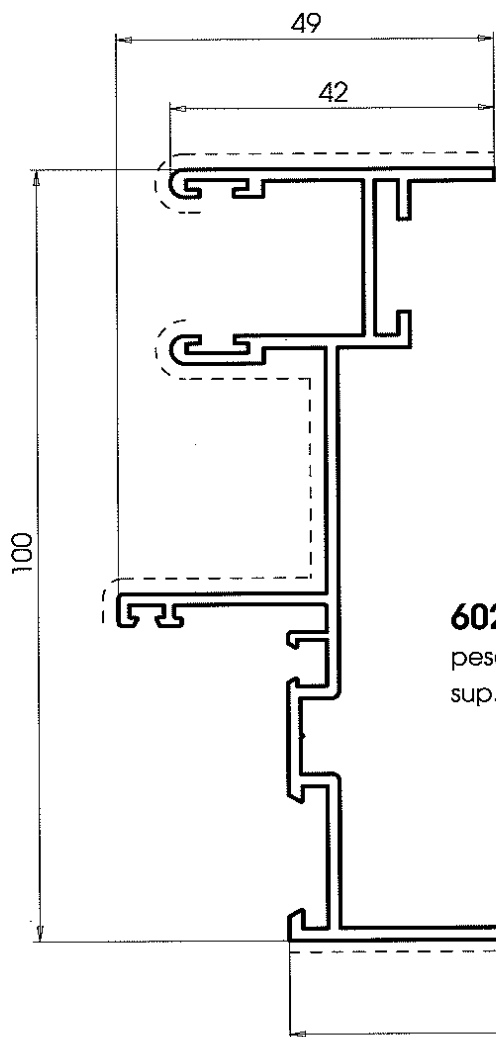

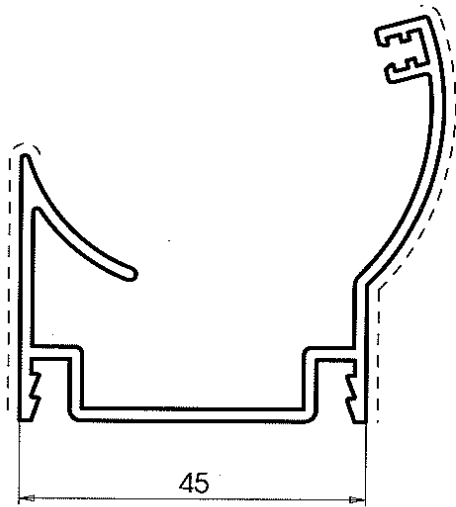

7009

peso: Kg./mt. 0.772
 sup. vista: mm. 91

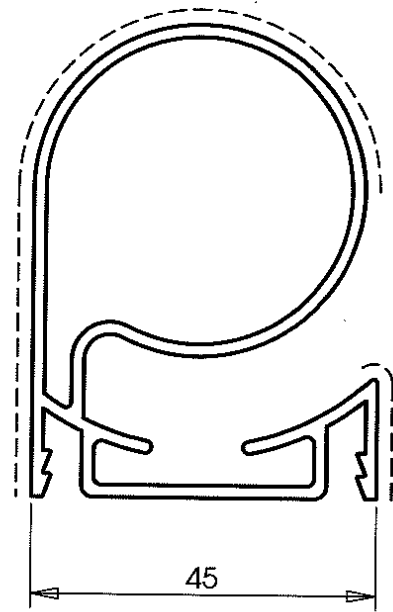

7010

peso: Kg./mt. 1.126
 sup. vista: mm. 139

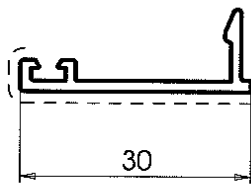

7020

peso: Kg./mt. 0.174
 sup. vista: mm. 35

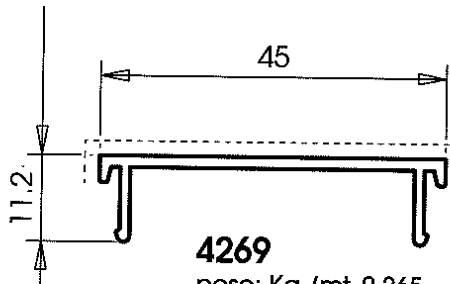

4269

peso: Kg./mt. 0.265
 sup. vista: mm. 53

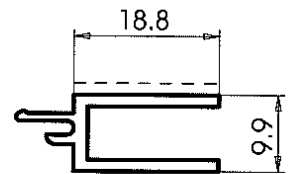

6005

peso: Kg./mt. 0.218
 sup. vista: mm. 19

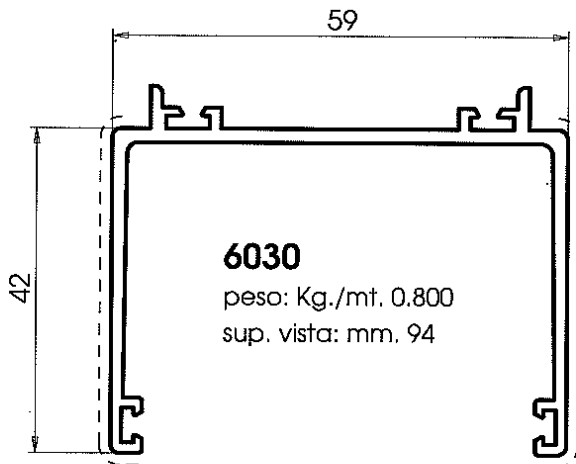

6030

peso: Kg./mt. 0.800
 sup. vista: mm. 94

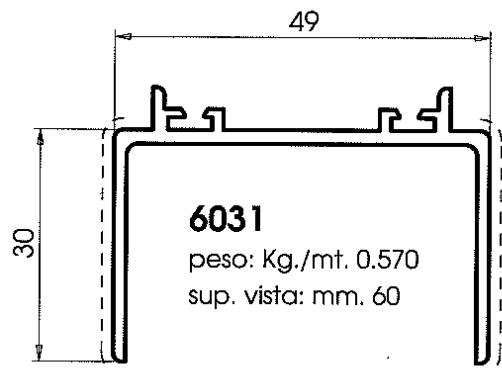

6031

peso: Kg./mt. 0.570
 sup. vista: mm. 60

TEKNALSYSTEM-NACO

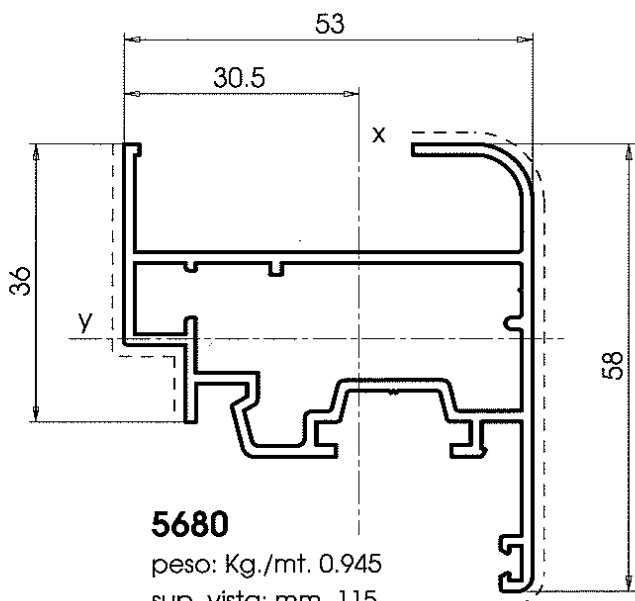

5680

peso: Kg./mt. 0.945
 sup. vista: mm. 115
 Jx cm⁴: 12.47

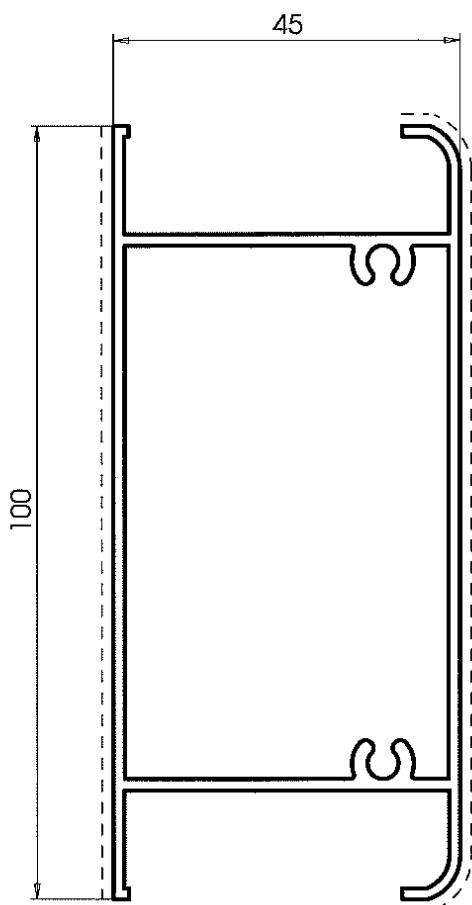

5681

peso: Kg./mt. 1.284
 sup. vista: mm. 208

LAMELLE-SLAT NACO

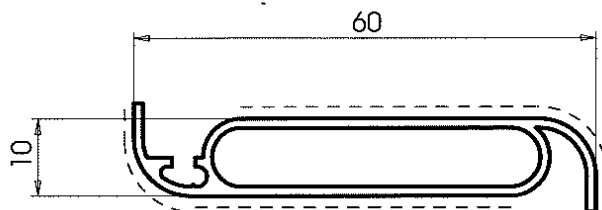

Z01316

peso: Kg./mt. 0.382
 sup. in vista: mm. 97

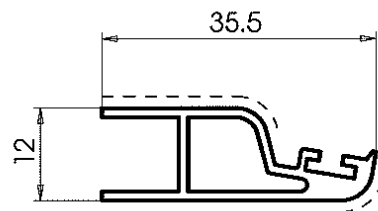

PE3378

peso: Kg./mt. 0.309
 sup. in vista: mm. 83

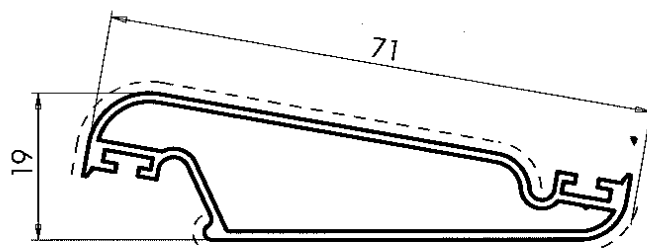

S03381

peso: Kg./mt. 0.531
 sup. in vista: mm. 140

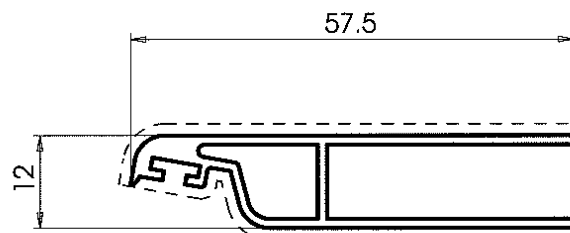

PE3382

peso: Kg./mt. 0.450
 sup. in vista: mm. 127

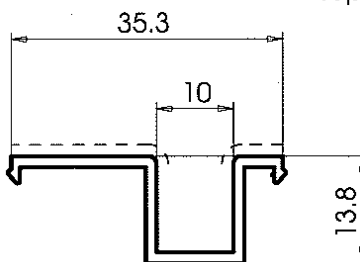

PE7014

peso: Kg./mt. 0.238
 sup. vista: mm. 26

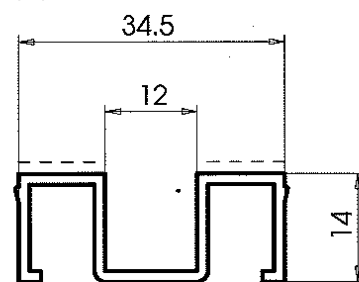

S07353

peso: Kg./mt. 0.332
 sup. vista: mm. 23

TEKNALSYSTEM

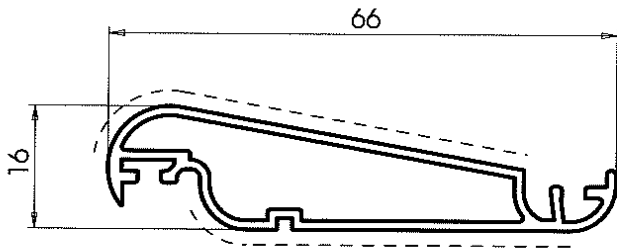

SO 3307

peso: Kg./mt. 0.531
 sup. in vista: mm. 125

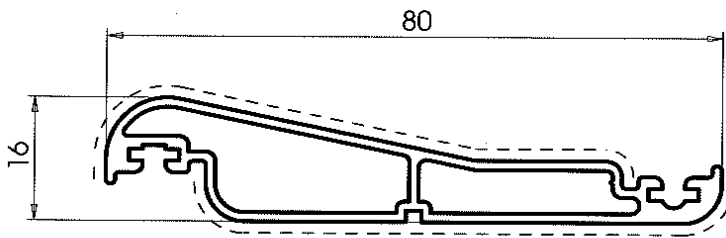

SO 3396

peso: Kg./mt. 0.689
 sup. in vista: mm. 158

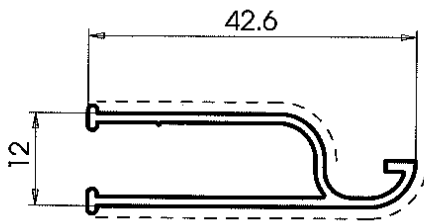

PE 3310

peso: Kg./mt. 0.294
 sup. in vista: mm. 82

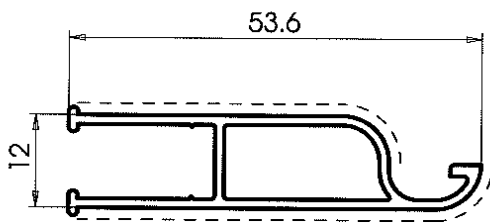

ZO 3311

peso: Kg./mt. 0.397
 sup. in vista: mm. 93

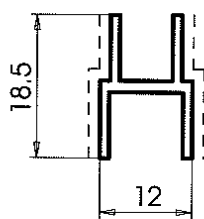

PE3379

peso: Kg./mt. 0.158
 sup. in vista: mm. 39

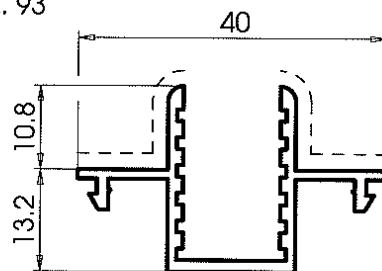

ZO 3309

peso: Kg./mt. 0.379
 sup. in vista: mm. 47

LAMELLE FISSE-SLAT FIXED

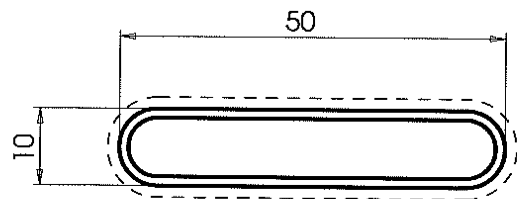

Z0682

peso: Kg./mt. 0.422
 sup. in vista: mm. 112

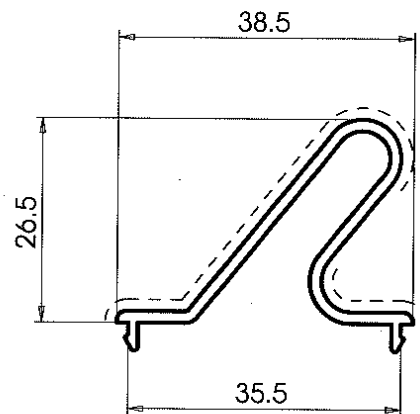

6016

peso: Kg./mt. 0.367
 sup. vista: mm. 87

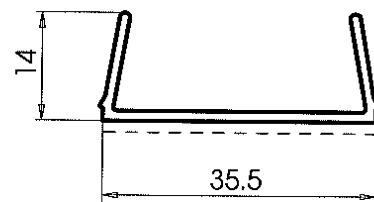

6017

peso: Kg./mt. 0.216
 sup. vista: mm. 35

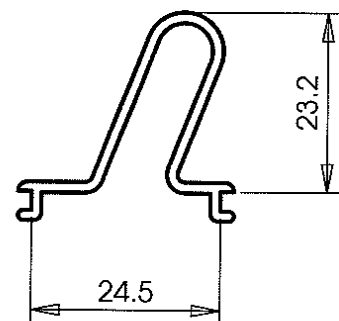

16104

peso: Kg./mt. 0.29
 sup. vista: mm. 70

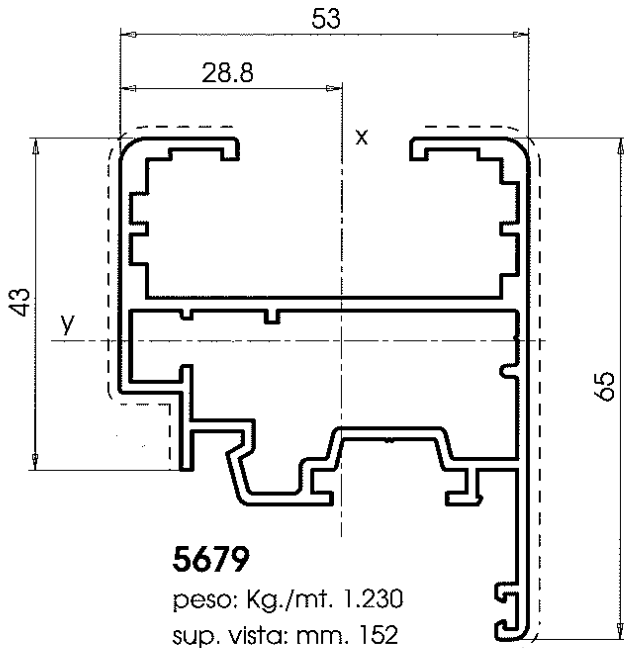

5679

peso: Kg./mt. 1.230
 sup. vista: mm. 152
 Jx cm⁴: 17.88

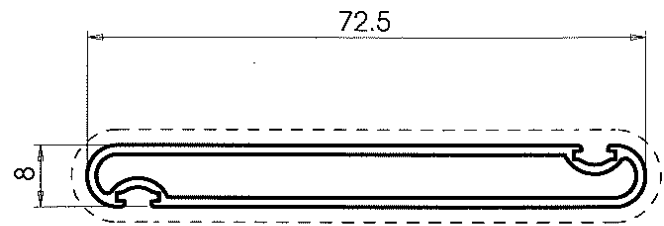

S01763

peso: Kg./mt. 0.506
 sup. in vista: mm. 154

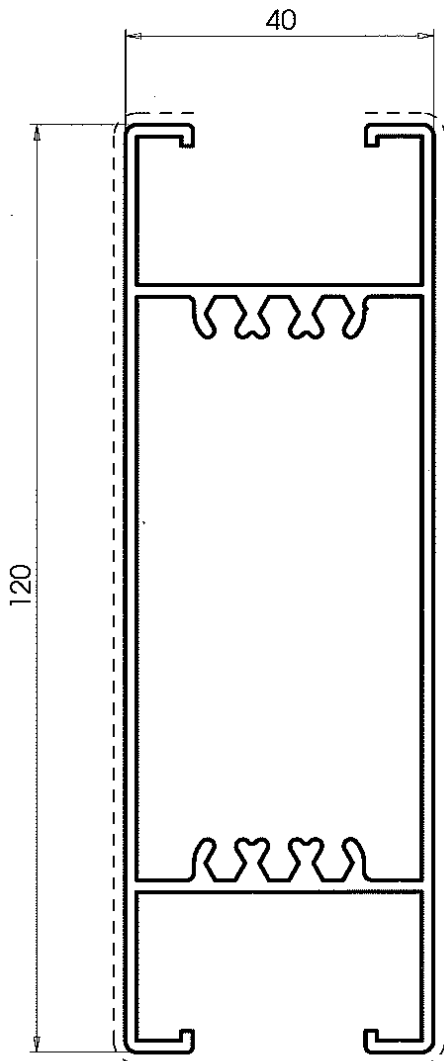

Z05565

peso: Kg./mt. 1.693
 sup. vista: mm. 270

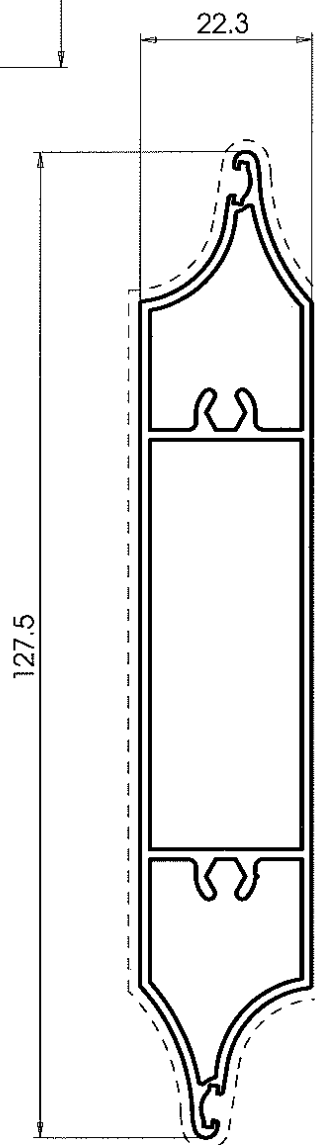

Z05566

peso: Kg./mt. 1.166
 sup. in vista: mm.285

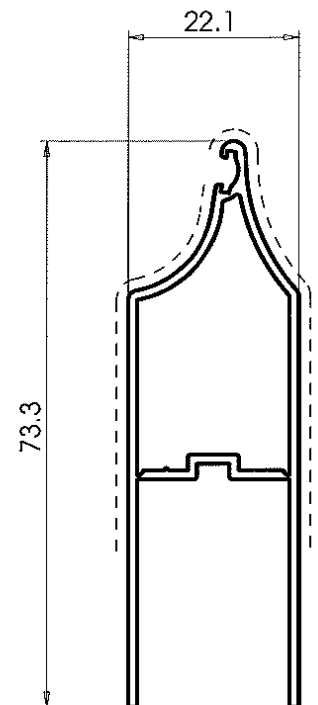

PE5567

peso: Kg./mt. 0.561
 sup. in vista: mm.116

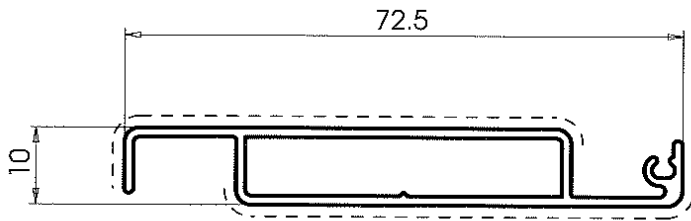

S01921

peso: Kg./mt. 0,486
 sup. in vista: mm.130

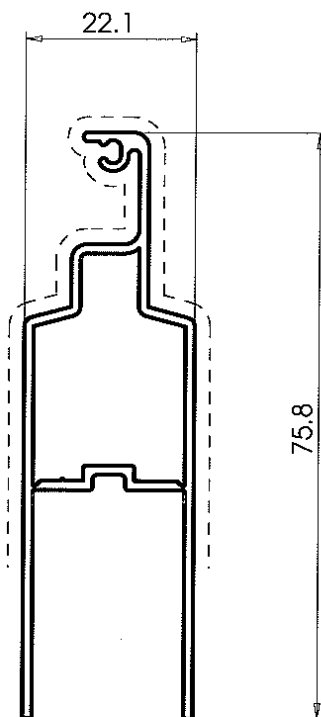

PE6306

peso: Kg./mt. 0,613
 sup. in vista: mm.155

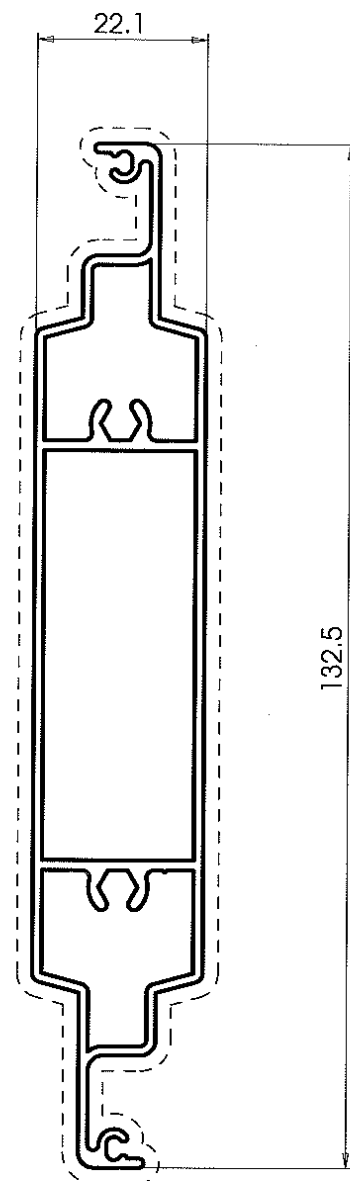

Z06307

peso: Kg./mt. 1,191
 sup. in vista: mm.349

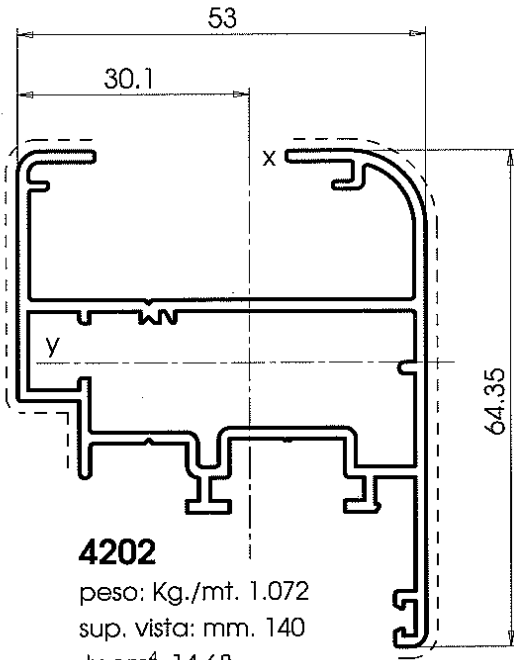

4202

peso: Kg./mt. 1.072
 sup. vista: mm. 140
 Jx cm⁴: 14.68

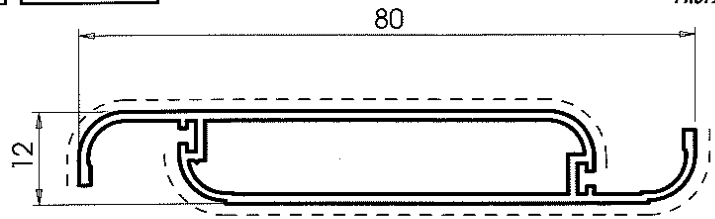

Z01254

peso: Kg./mt. 0.542
 sup. in vista: mm. 165

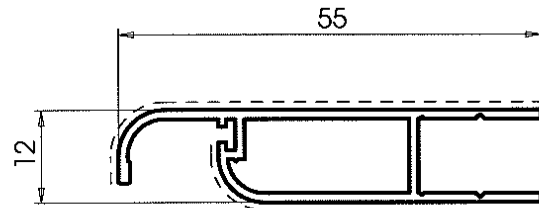

Z01262

peso: Kg./mt. 0.405
 sup. in vista: mm. 113

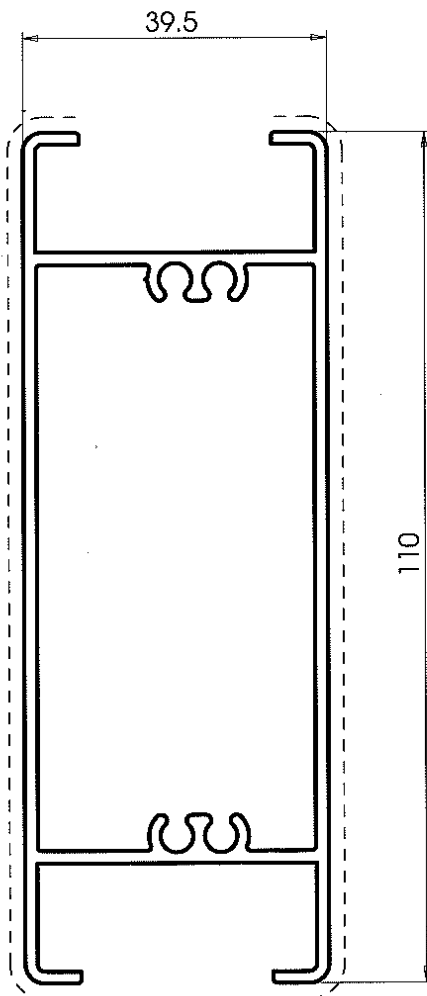

Z06344

peso: Kg./mt. 1.523
 sup. vista: mm. 249

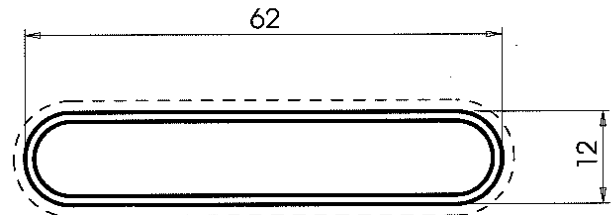

S01298

peso: Kg./mt. 0.435
 sup. in vista: mm. 147

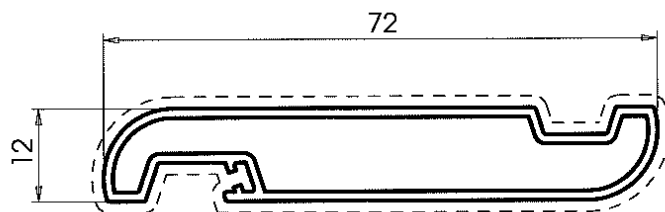

Z04343

peso: Kg./mt. 0.562
 sup. in vista: mm. 178

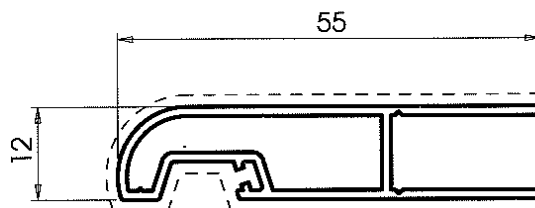

Z04377

peso: Kg./mt. 0.443
 sup. in vista: mm. 130

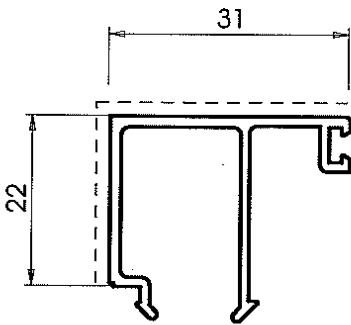

4297

peso: Kg./mt. 0.329
 sup. vista: mm. 53

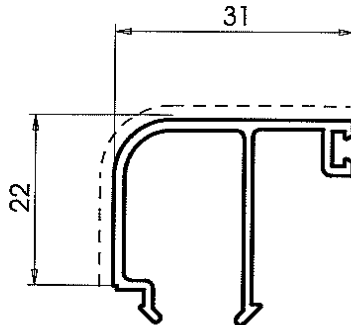

4196

peso: Kg./mt. 0.319
 sup. vista: mm. 49

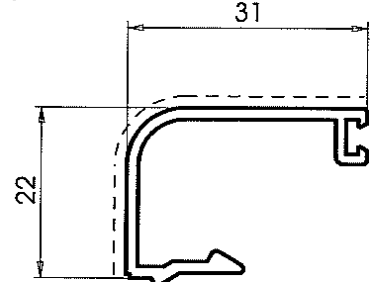

4197

peso: Kg./mt. 0.297
 sup. vista: mm. 48

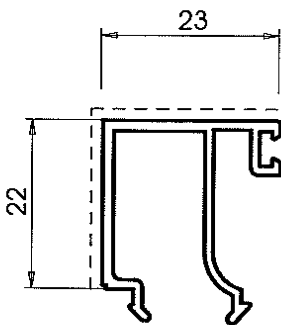

4298

peso: Kg./mt. 0.305
 sup. vista: mm. 45

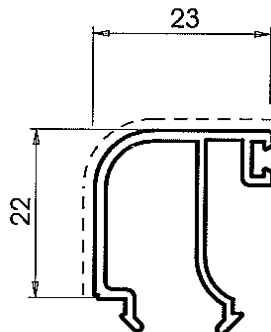

4195

peso: Kg./mt. 0.292
 sup. vista: mm. 41

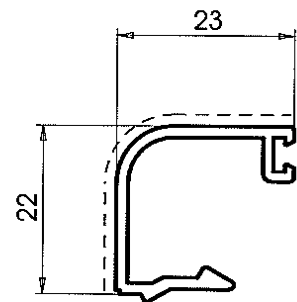

4292

peso: Kg./mt. 0.264
 sup. vista: mm. 40

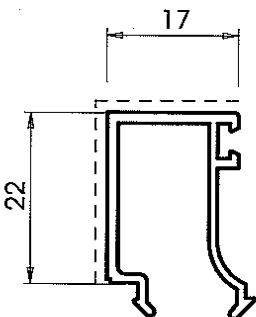

4296

peso: Kg./mt. 0.265
 sup. vista: mm. 39

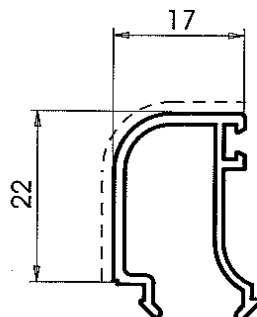

4299

peso: Kg./mt. 0.254
 sup. vista: mm. 35

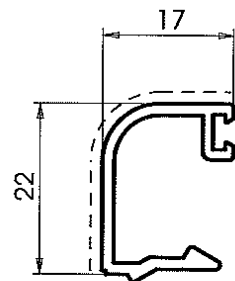

4291

peso: Kg./mt. 0.240
 sup. vista: mm. 34

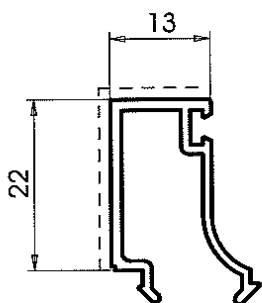

4294

peso: Kg./mt. 0.254

sup. vista: mm. 35

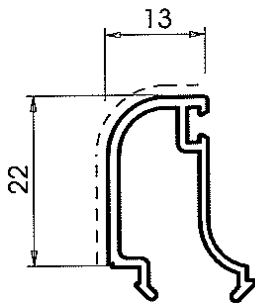

4295

peso: Kg./mt. 0.243

sup. vista: mm. 30

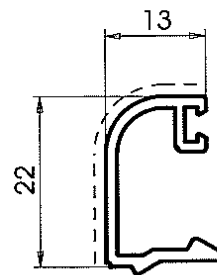

4290

peso: Kg./mt. 0.224

sup. vista: mm. 30

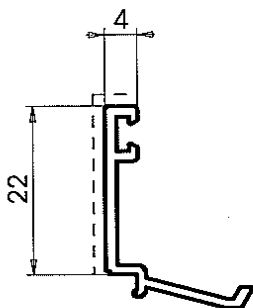

4293

peso: Kg./mt. 0.183

sup. vista: mm. 26

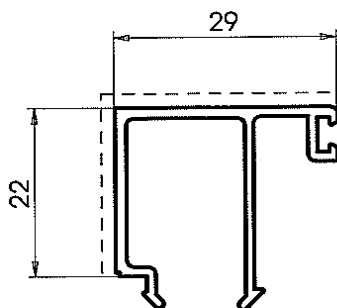

9040

peso: Kg./mt. 0.321

sup. vista: mm. 51

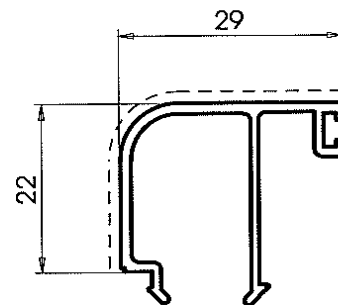

9041

peso: Kg./mt. 0.311

sup. vista: mm. 49

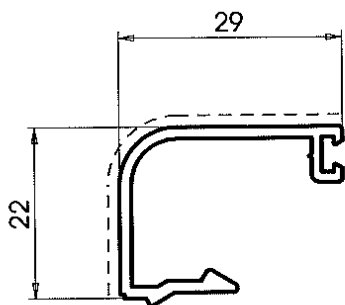

9042

peso: Kg./mt. 0.289

sup. vista: mm. 47

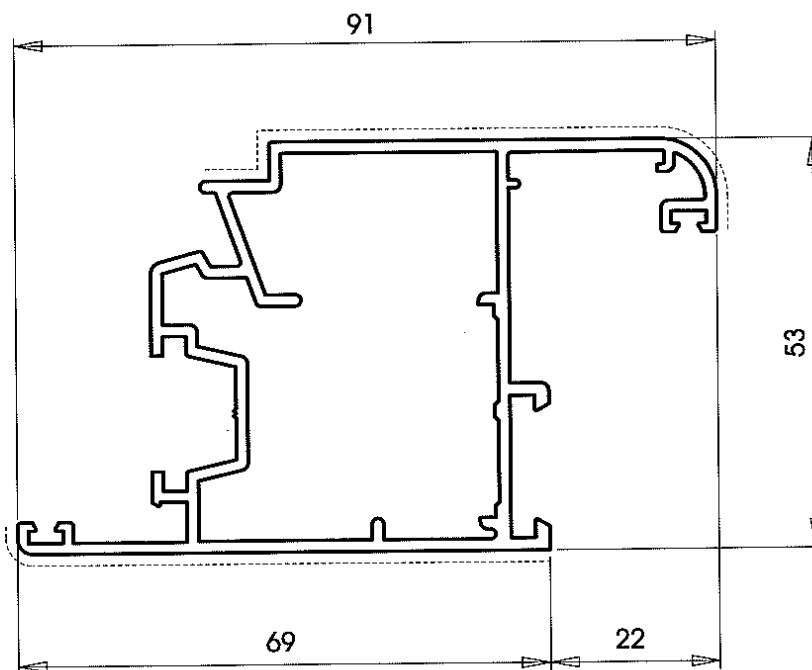

9533

peso: Kg./mt. 1.331

sup. vista: mm. 151

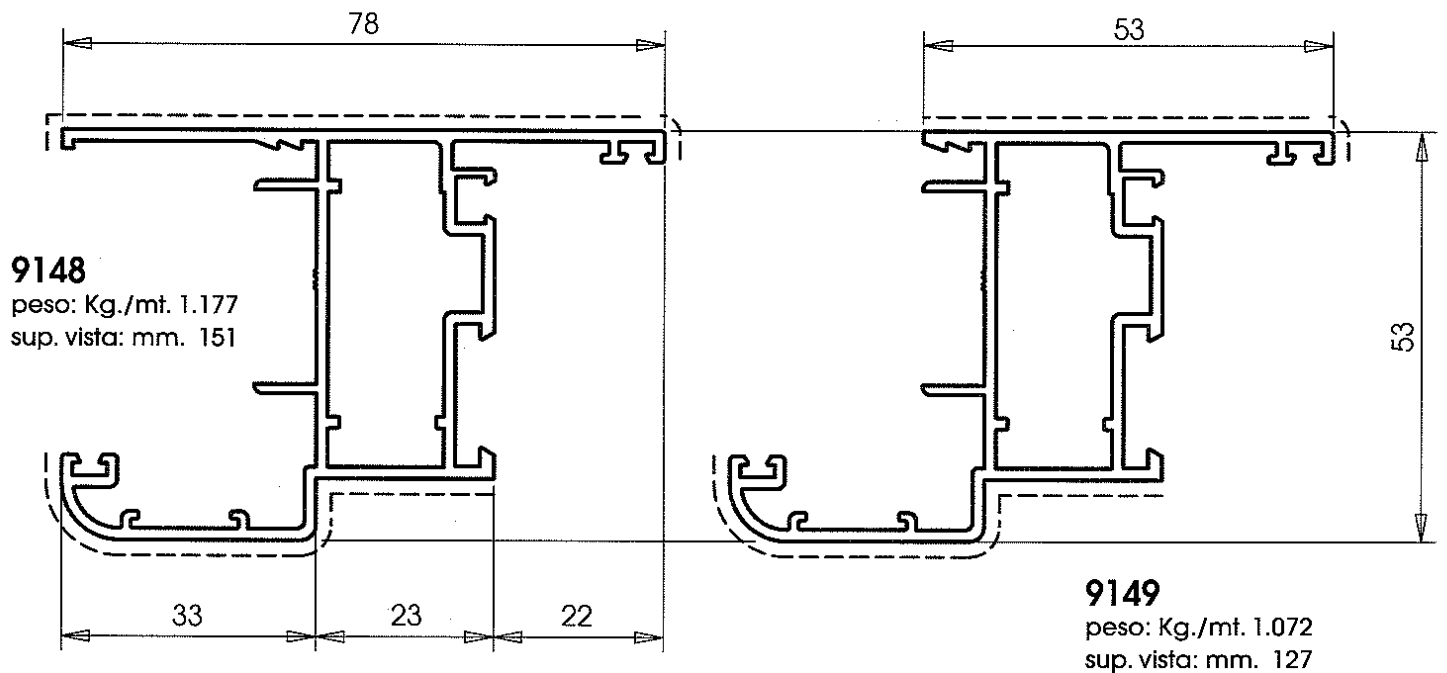
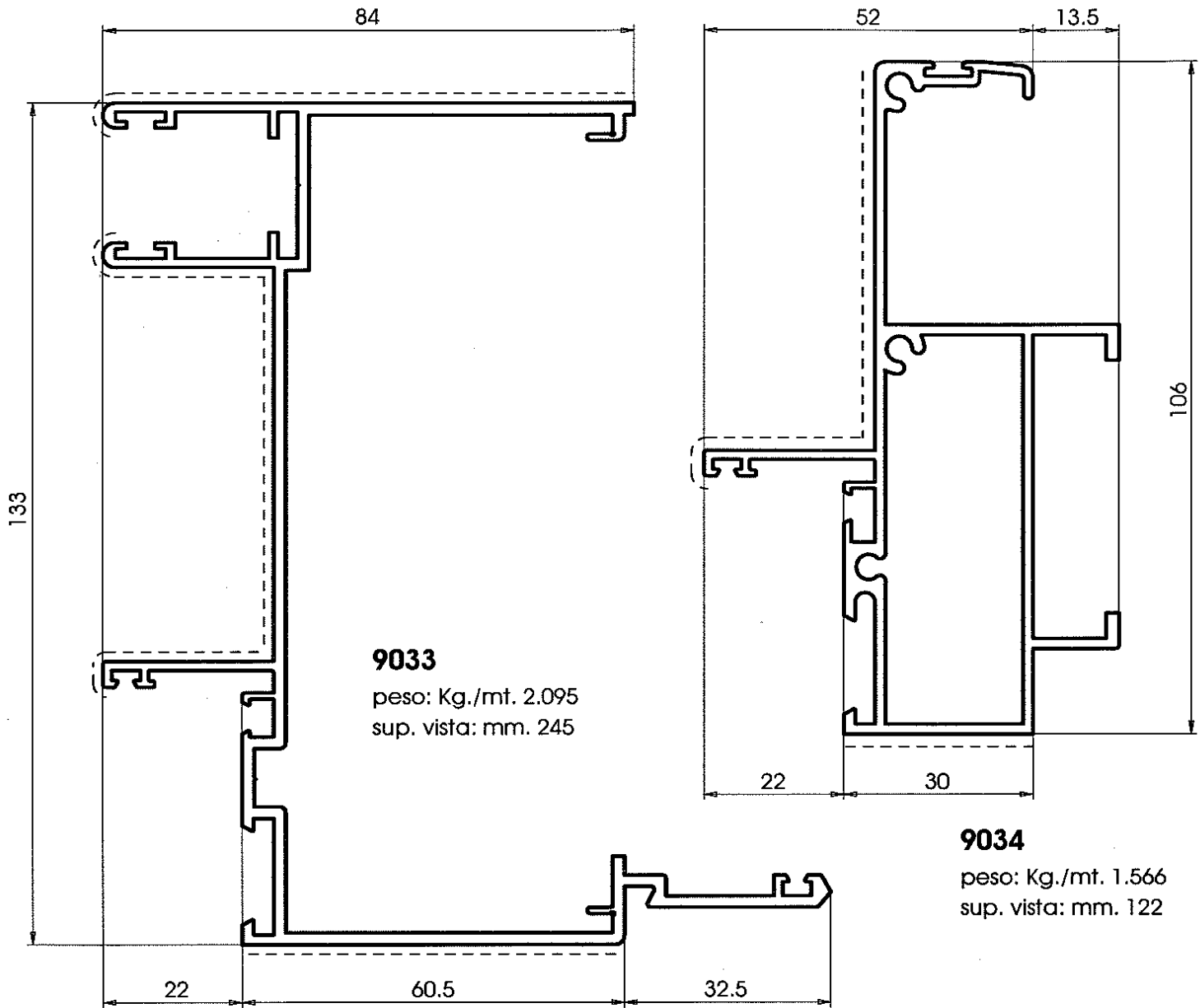



Note: = Profili po narudžbi

= Profili na stanju u Sarajevu

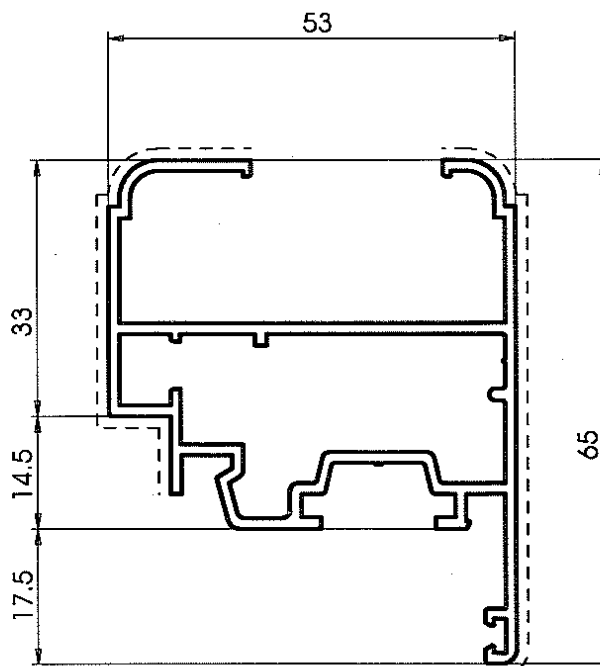
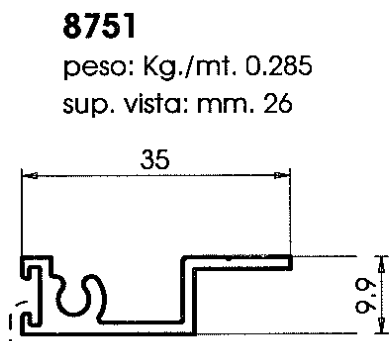
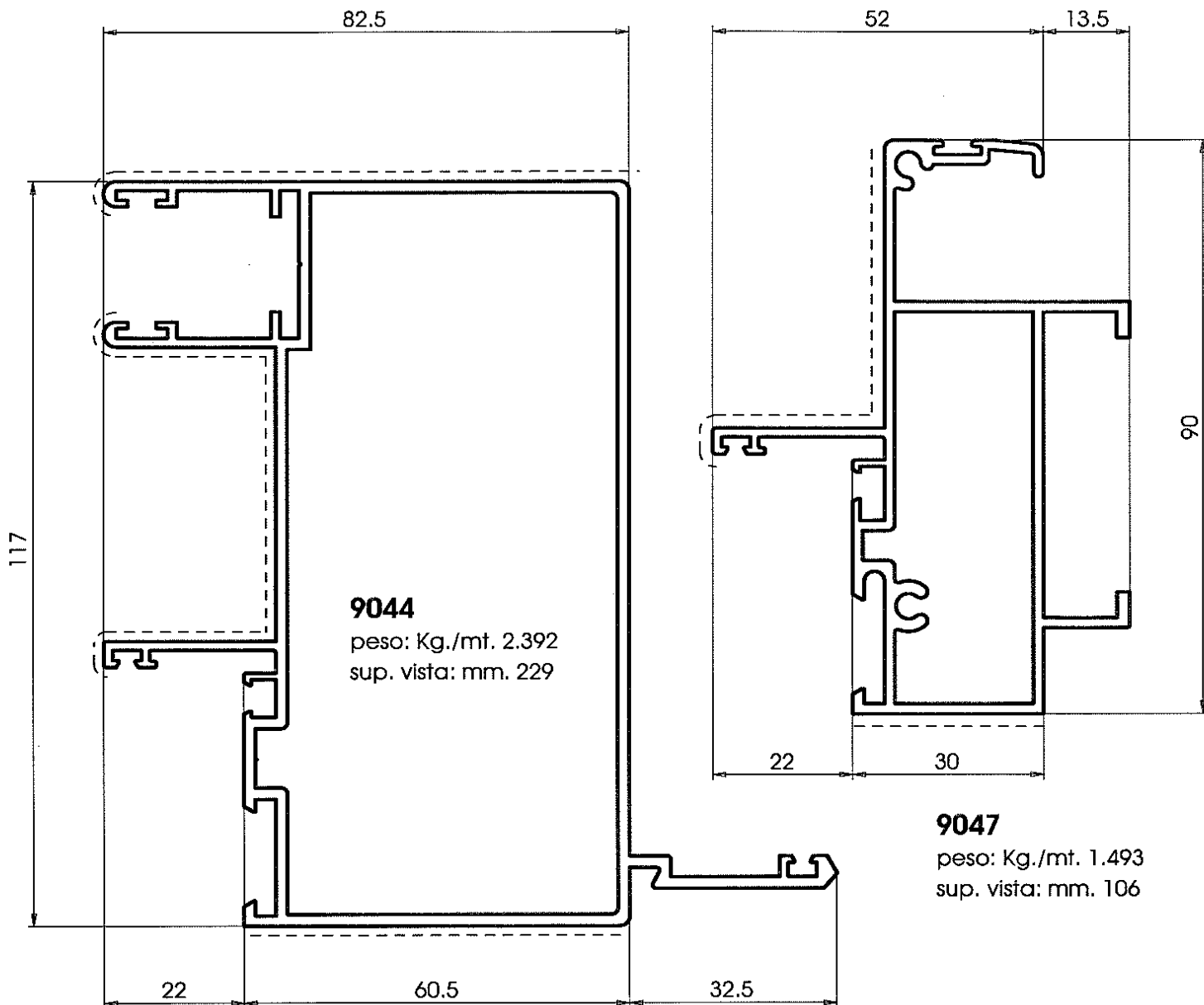
* Ostali profili su na redovnom lageru u Bolonji



Note:  = Profili po narudžbi

 = Profili na stanju u Sarajevu

* Ostali profili su na redovnom lageru u Bolonji

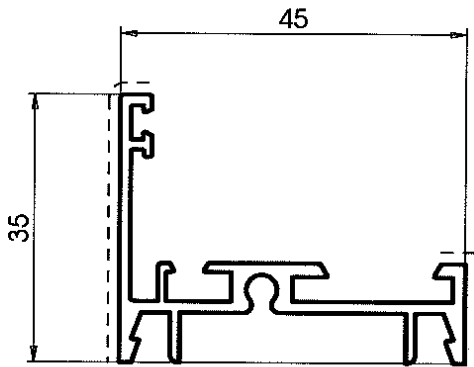
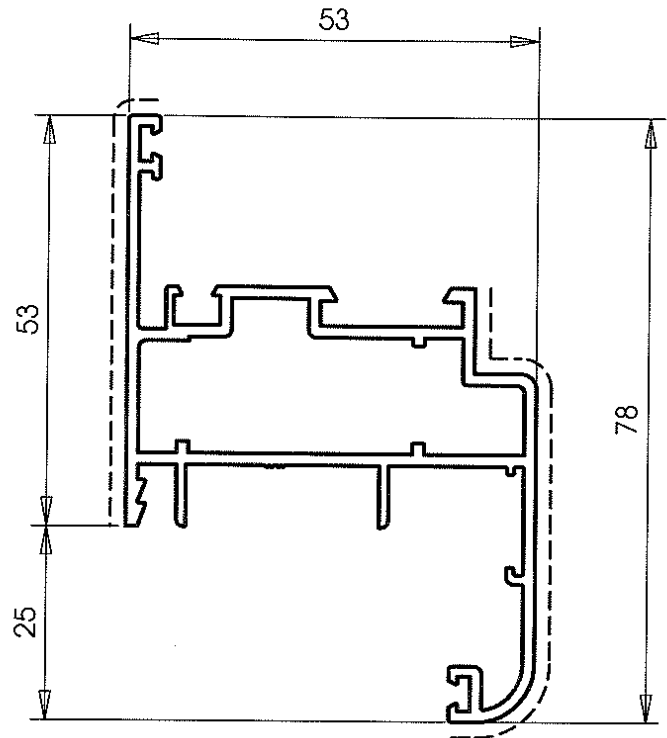
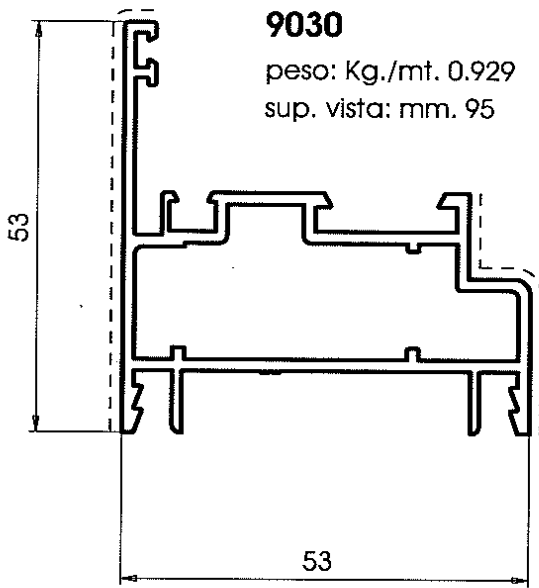

9031
peso: Kg./mt. 1.096
sup. vista: mm. 127

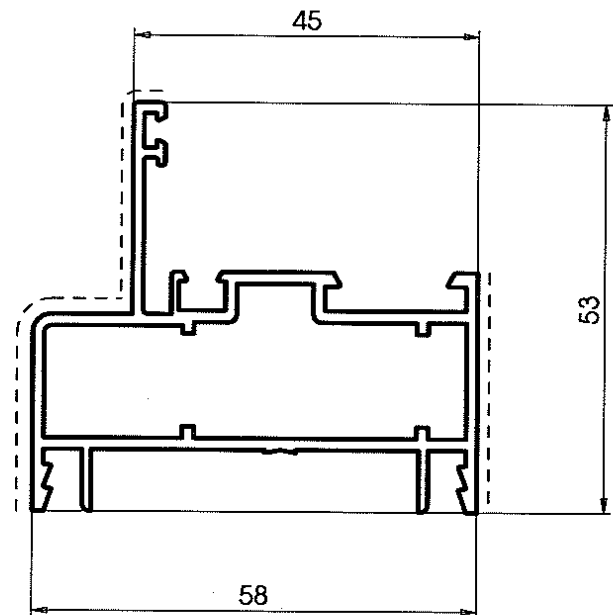

9137
peso: Kg./mt. 0.381
sup. vista: mm. 35

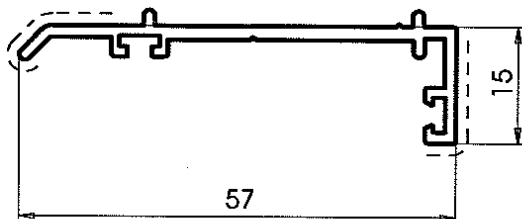

9011
peso: Kg./mt. 0.975
sup. vista: mm. 99

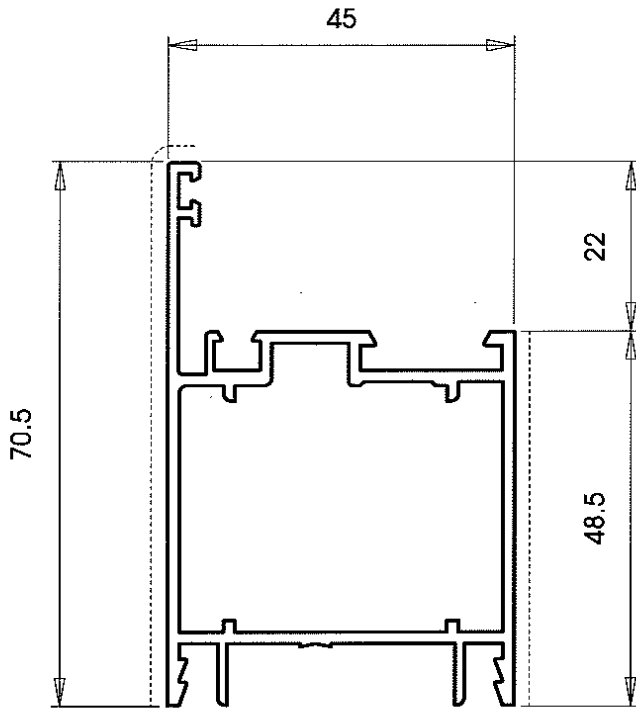

9035

peso: Kg./mt. 1.034
sup. vista: mm. 122

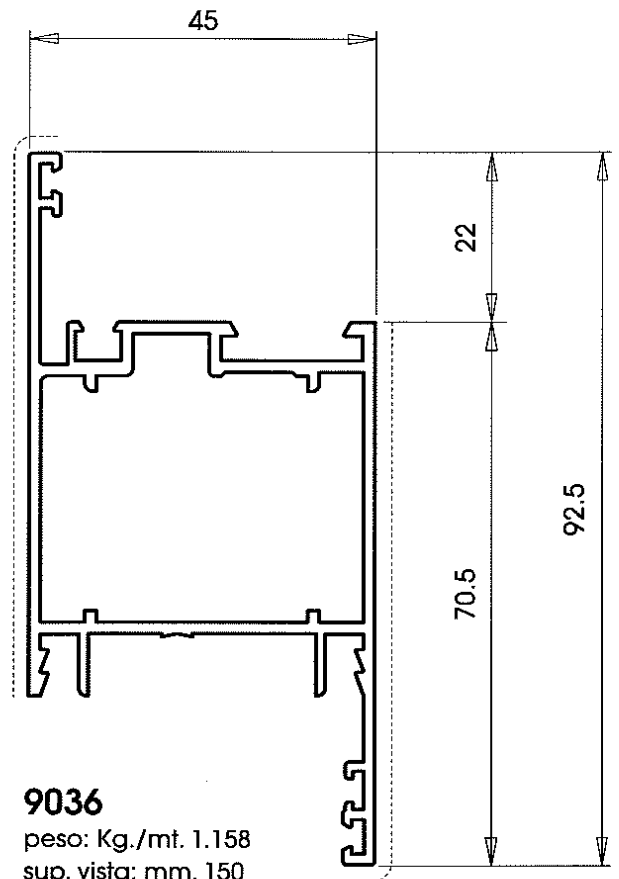

9036

peso: Kg./mt. 1.158
sup. vista: mm. 150

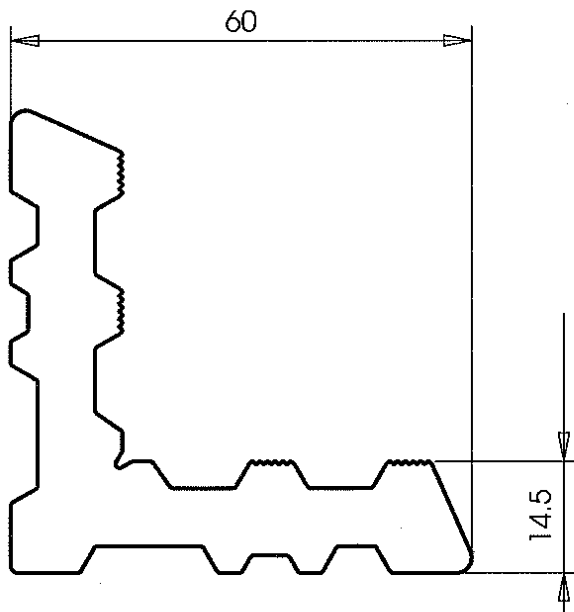

9026

peso: Kg./mt. 3.026

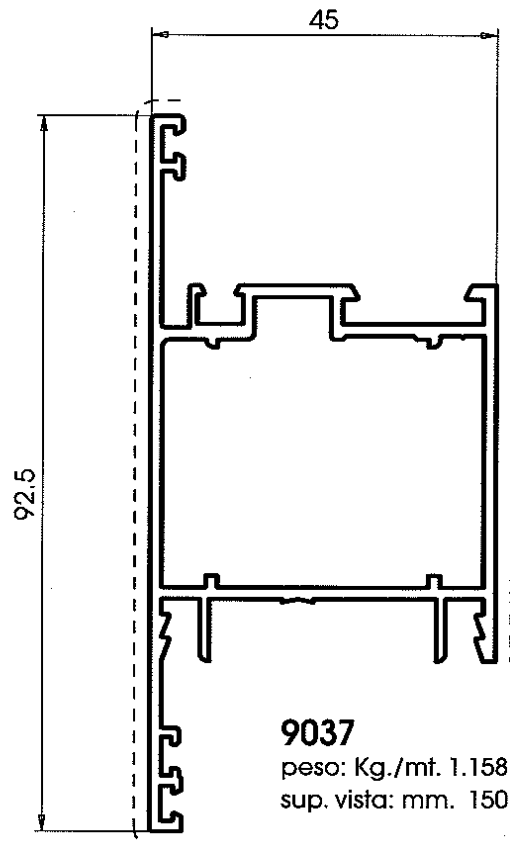

9037

peso: Kg./mt. 1.158
sup. vista: mm. 150

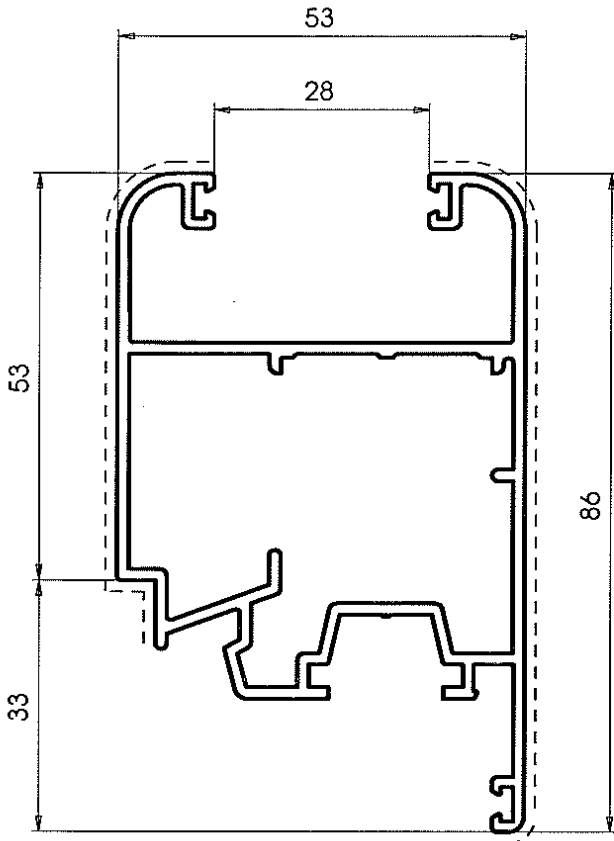

9154

peso: Kg./mt. 1.385
sup. vista: mm. 180

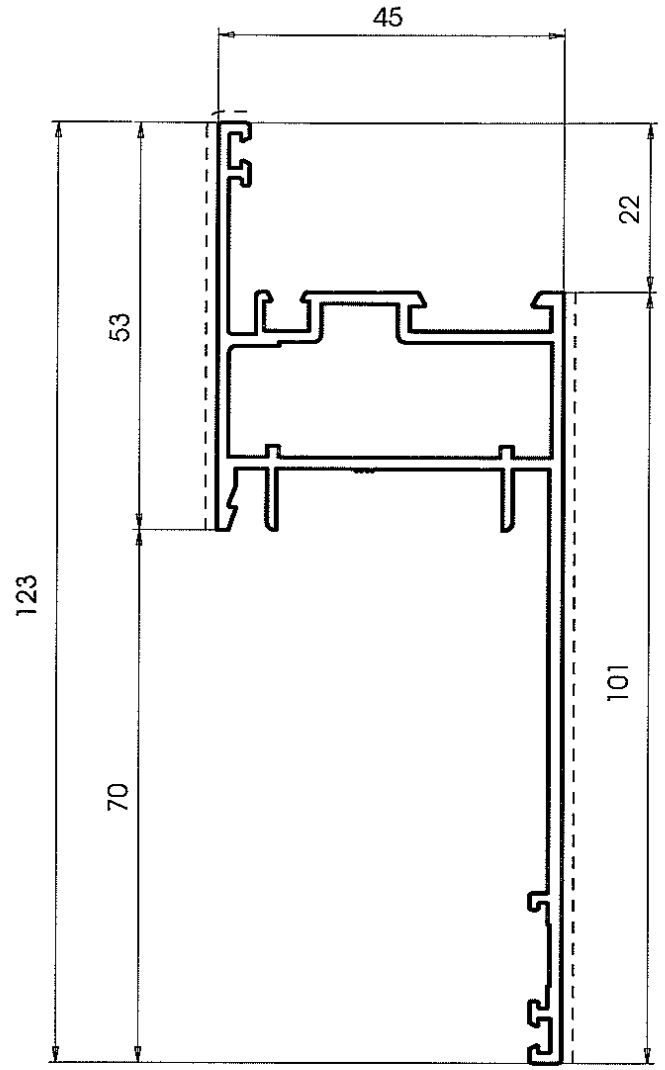

9155

peso: Kg./mt. 1.231
sup. vista: mm. 163

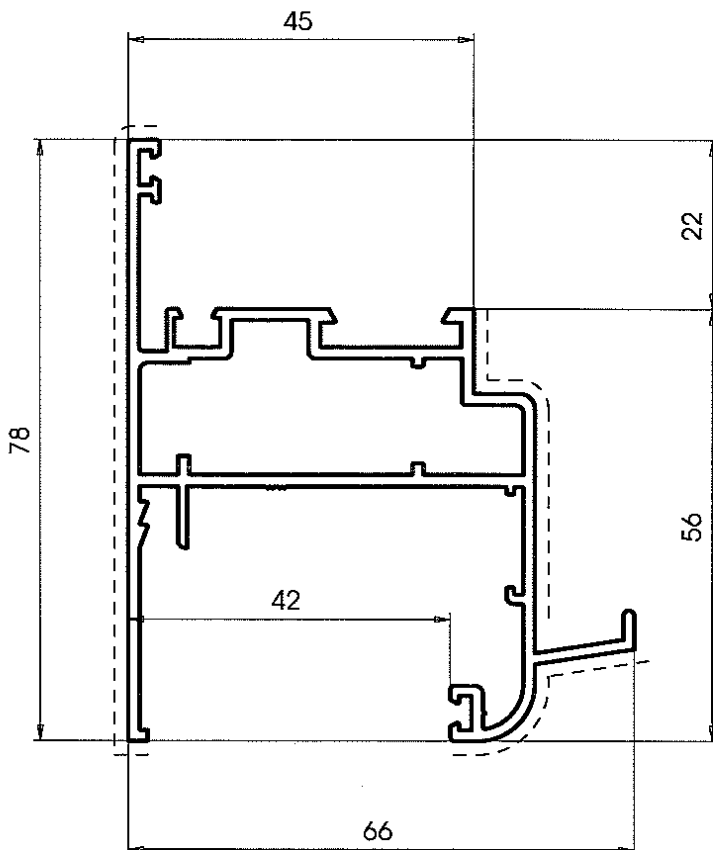

9160

peso: Kg./mt. 1.242
sup. vista: mm. 162

Note:  = Profili po narudžbi

 = Profili na stanju u Sarajevu

* Ostali profili su na redovnom lageru u Bolonji

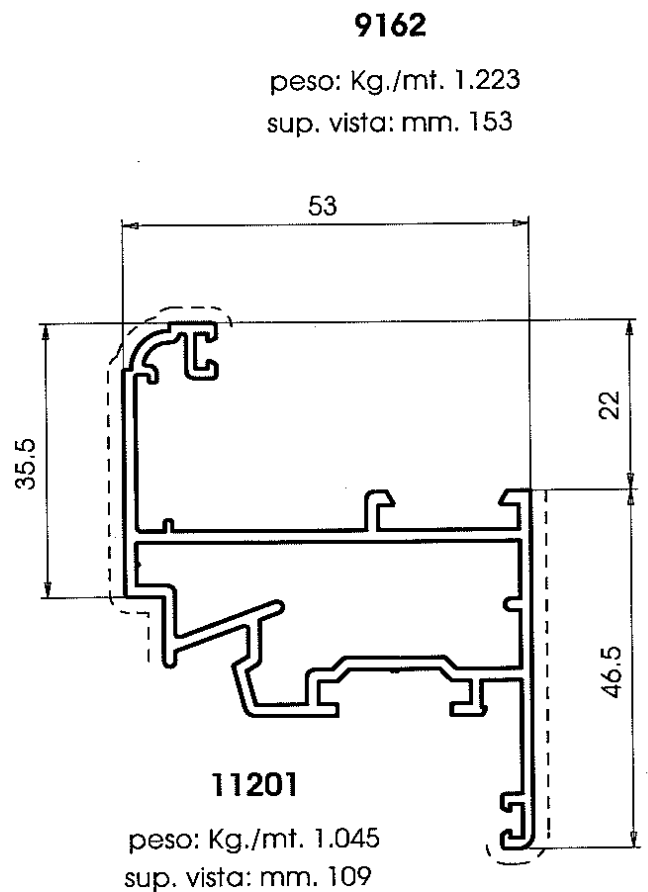
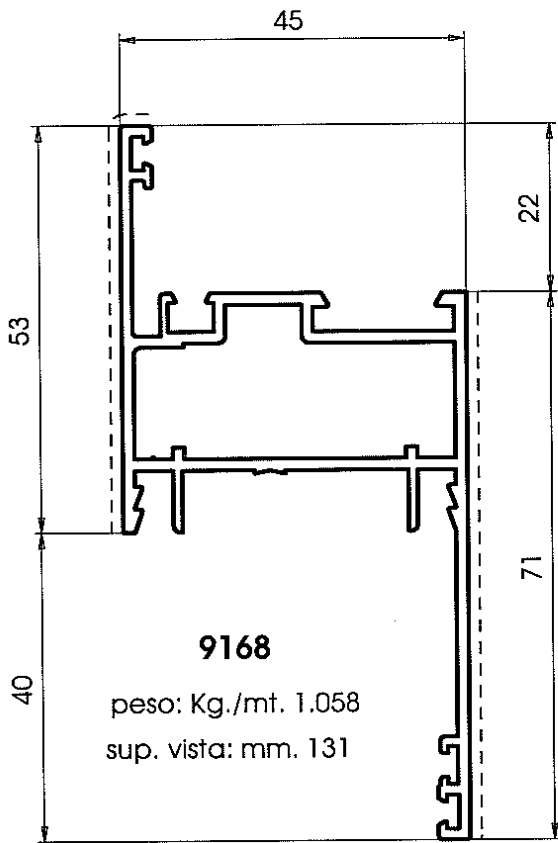
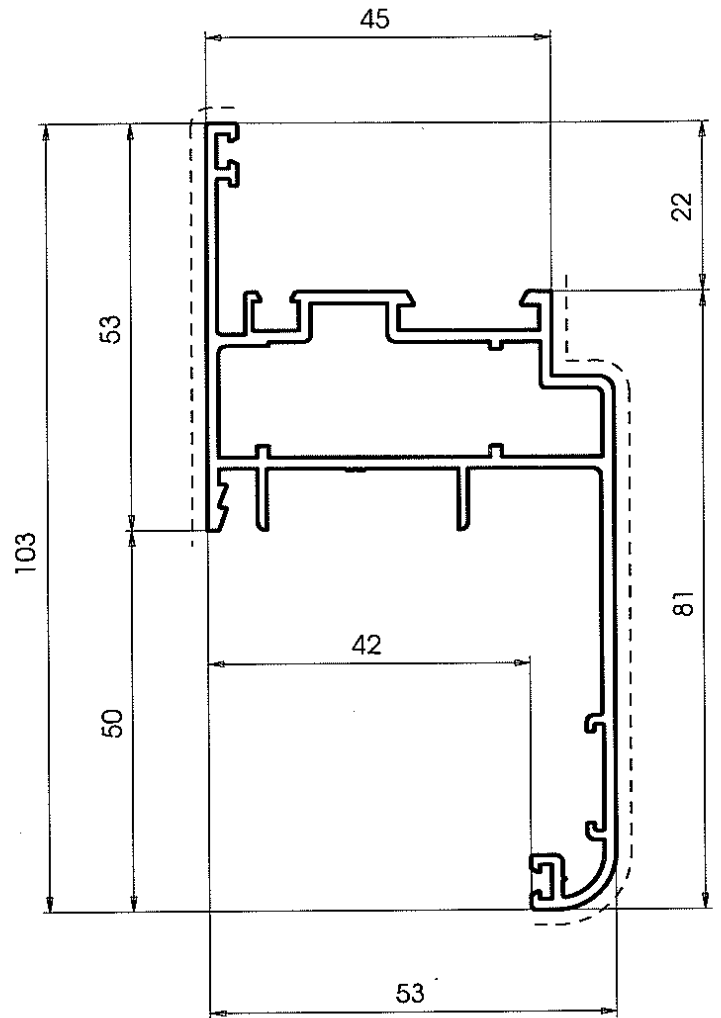
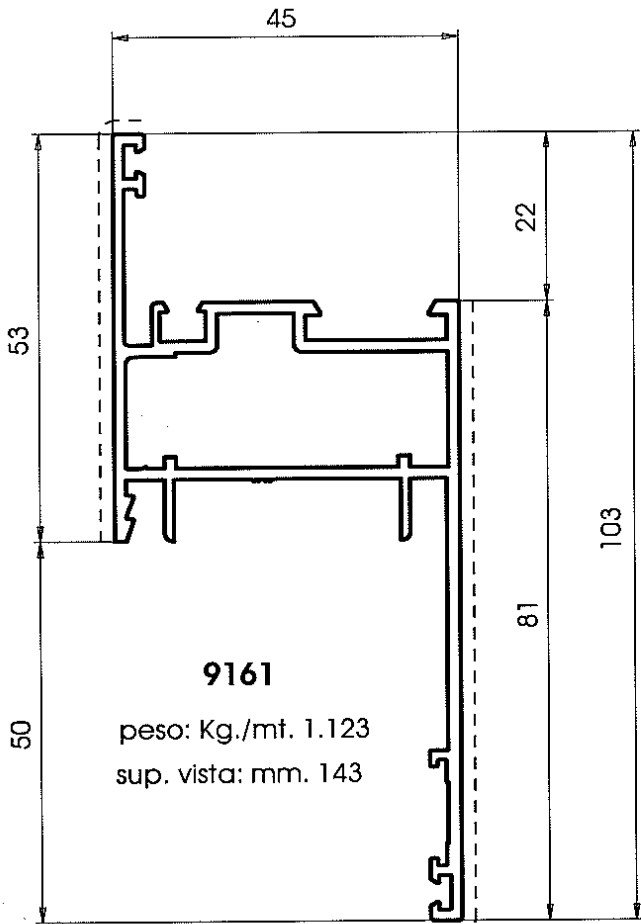

Note: = Profili po narudžbi

= Profili na stanju u Sarajevu

* Ostali profili su na redovnom lageru u Bolonji

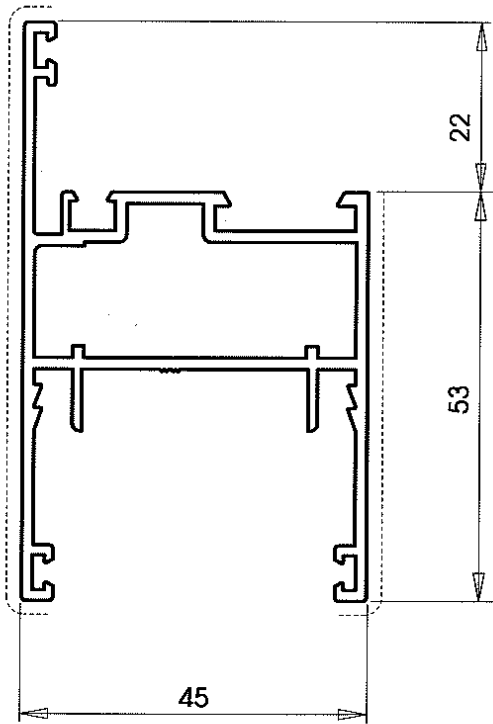

11027

peso: Kg./mt. 1.085
sup. vista: mm. 141

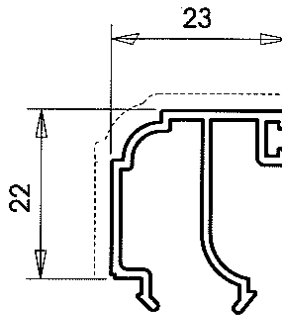

11202

peso: Kg./mt. 0.281
sup. vista: mm. 42

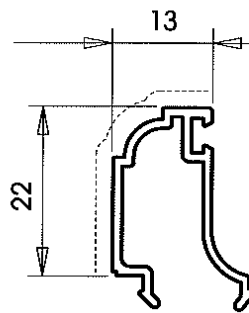

11203

peso: Kg./mt. 0.232
sup. vista: mm. 32

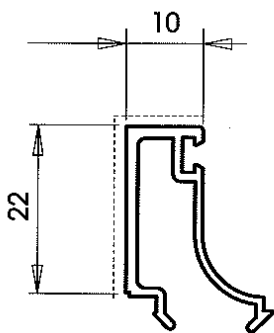

9159

peso: Kg./mt. 0.249
sup. vista: mm. 32

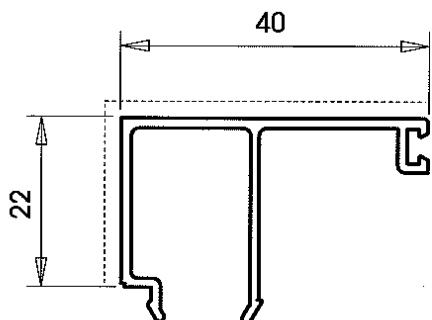

9175

peso: Kg./mt. 0.365

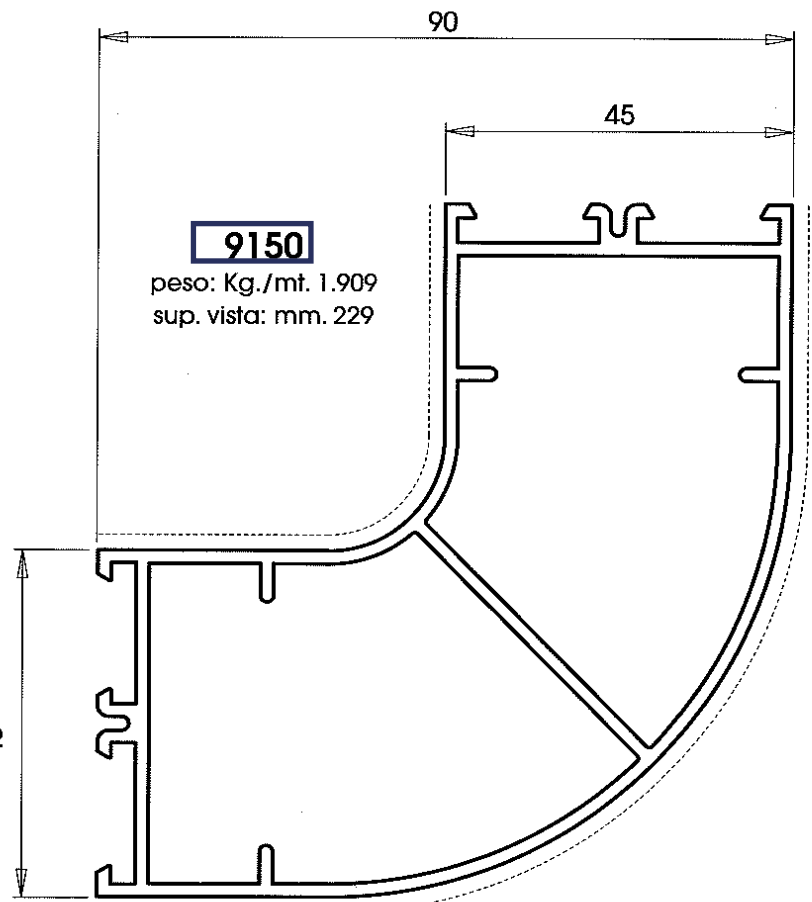

9150

peso: Kg./mt. 1.909
sup. vista: mm. 229

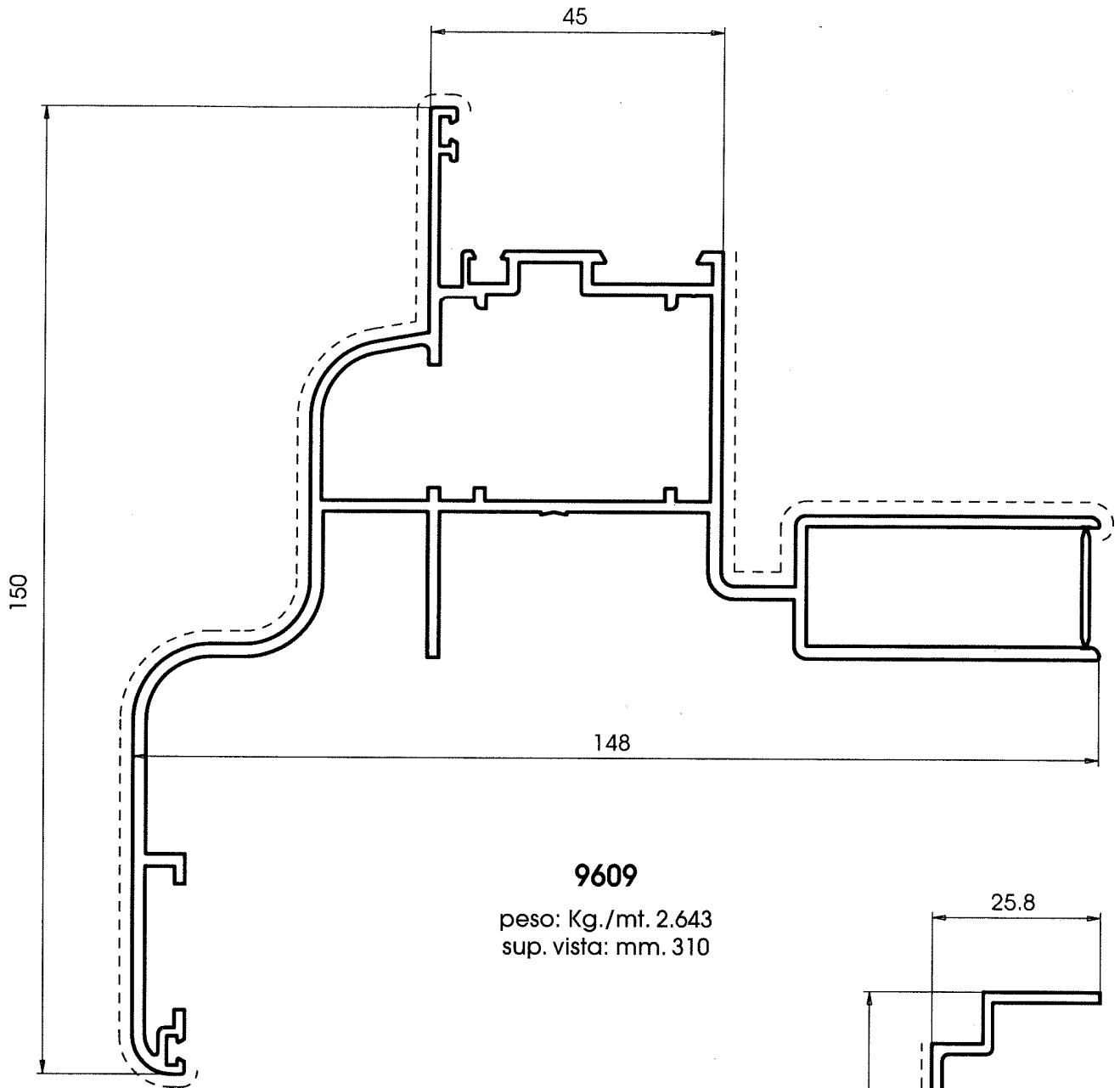

9609

peso: Kg./mt. 2.643
sup. vista: mm. 310

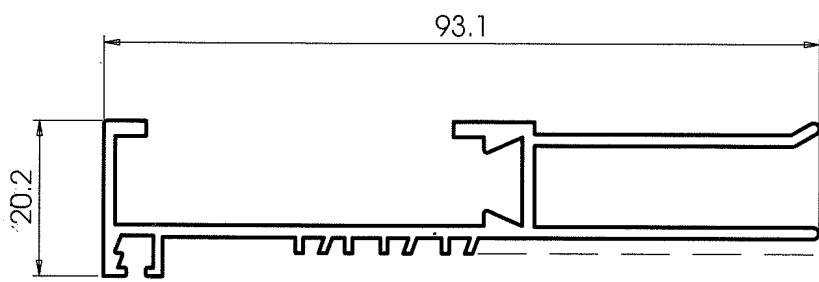

11016

peso: Kg./mt. 0.842
sup. vista: mm. 45

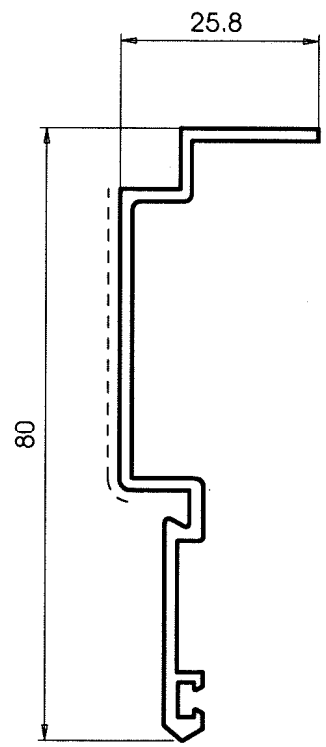

11015

peso: Kg./mt. 0.551
sup. vista: mm. 40

Note:  = Profili po narudžbi

 = Profili na stanju u Sarajevu

* Ostali profili su na redovnom lageru u Bolonji

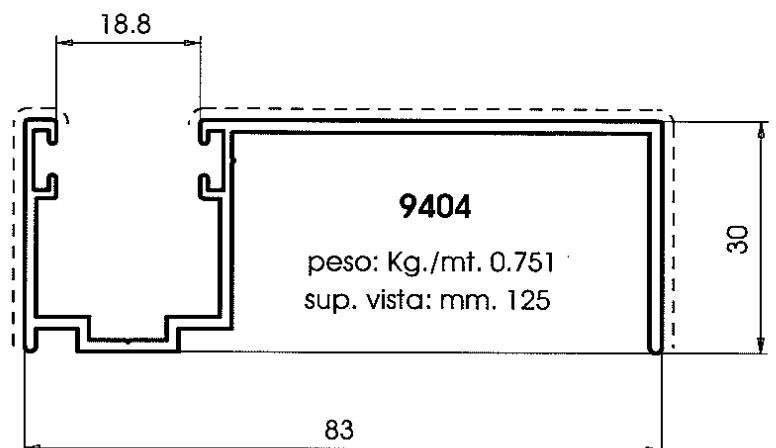
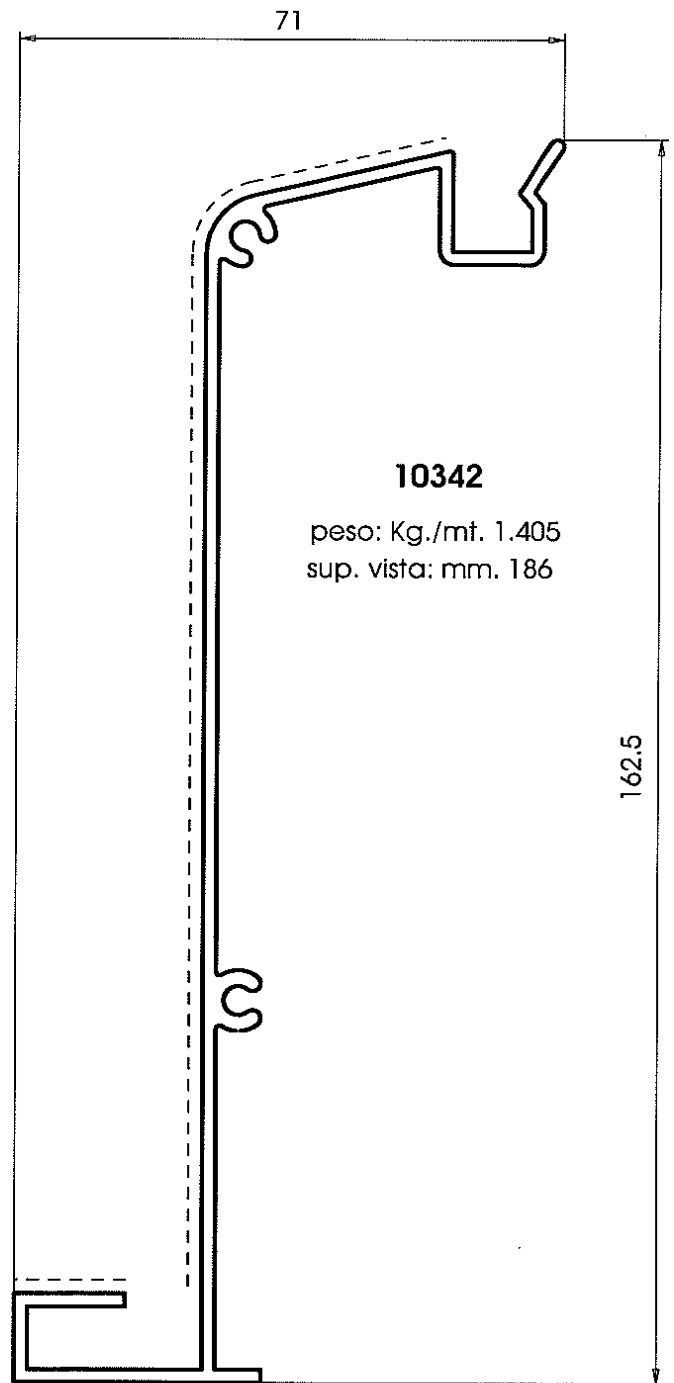
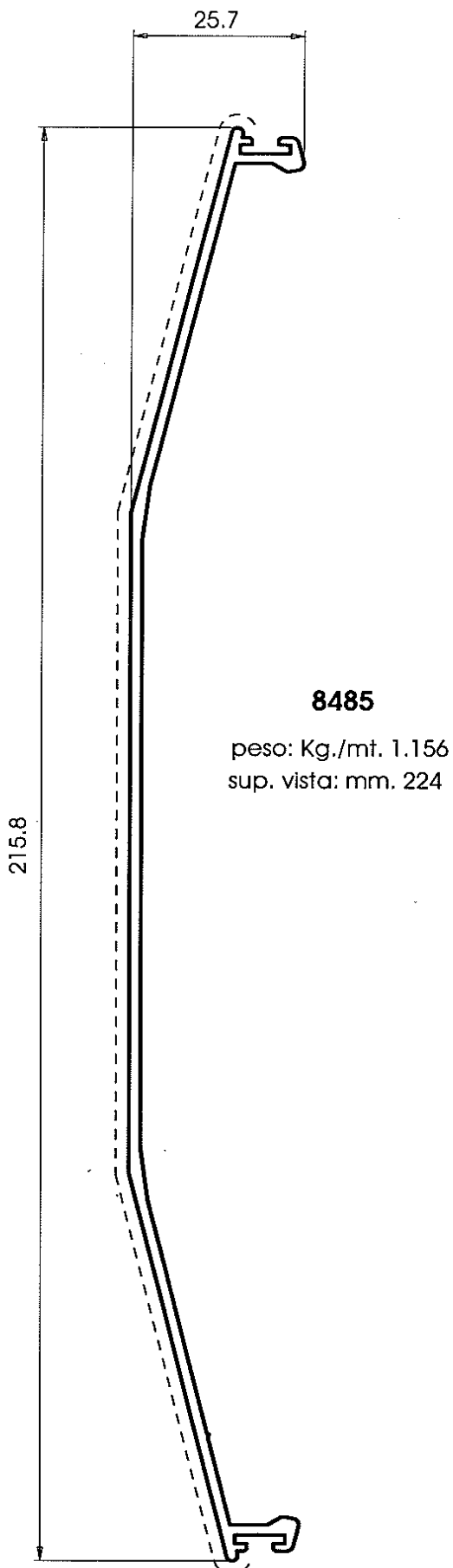

Note:  = Profili po narudžbi

 = Profili na stanju u Sarajevu

* Ostali profili su na redovnom lageru u Bolonji

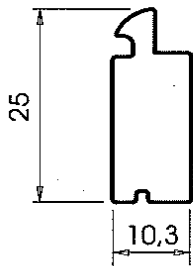

11017
peso Kg./mt. 0.575

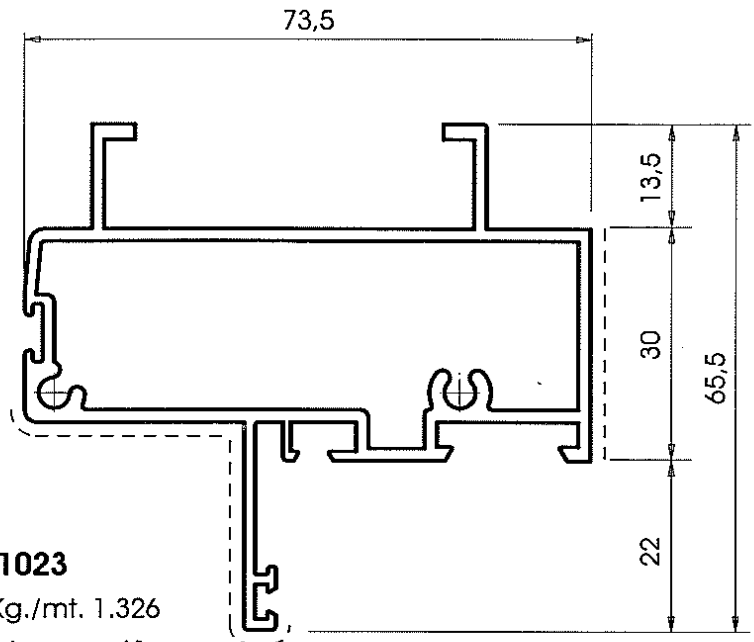

11023
peso Kg./mt. 1.326
sup. vista: mm. 61

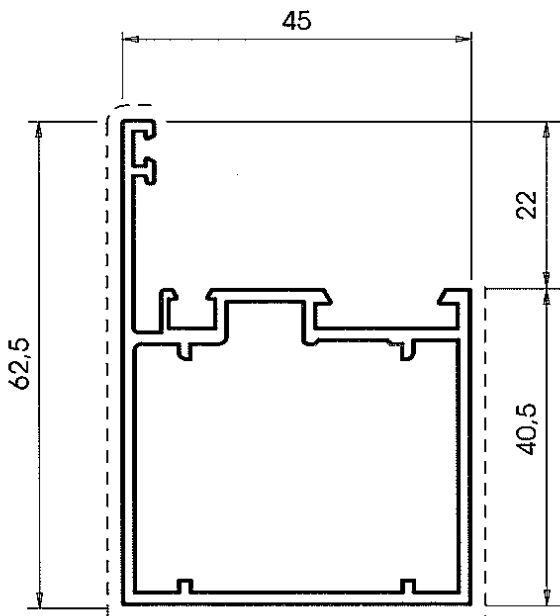

11021
peso Kg./mt. 0.899
sup. vista: mm. 151

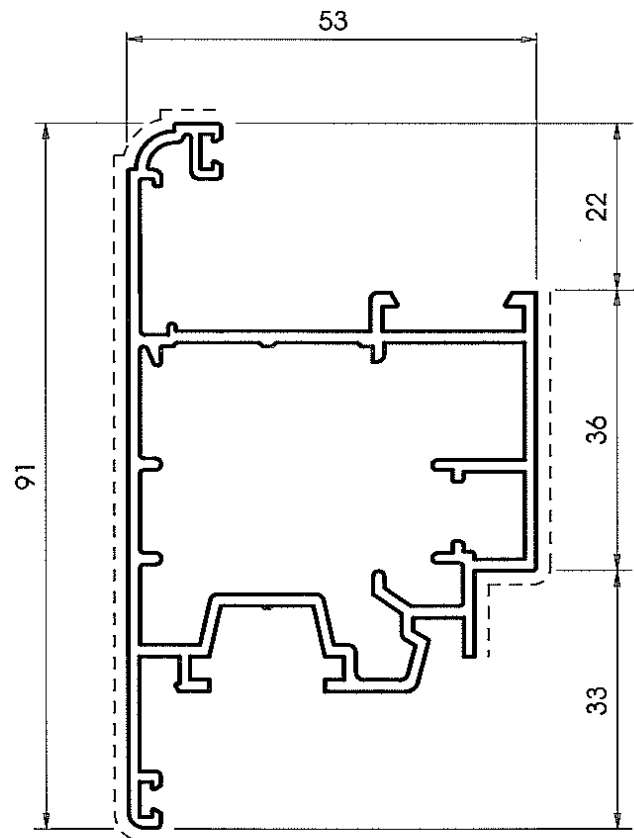

11028
peso Kg./mt. 1.391
sup. vista: mm. 159

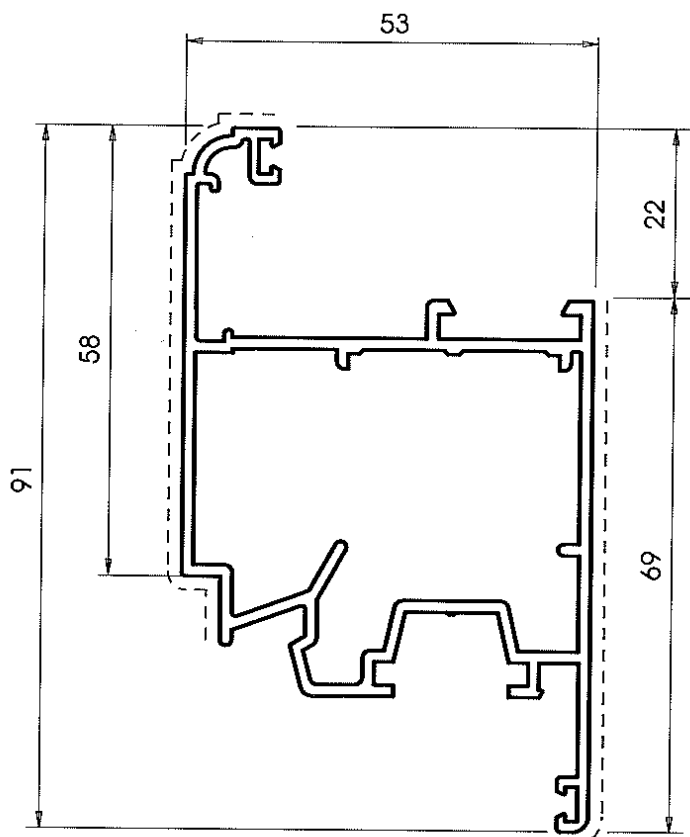

11029

peso Kg./mt. 1.312
sup. vista: mm. 153

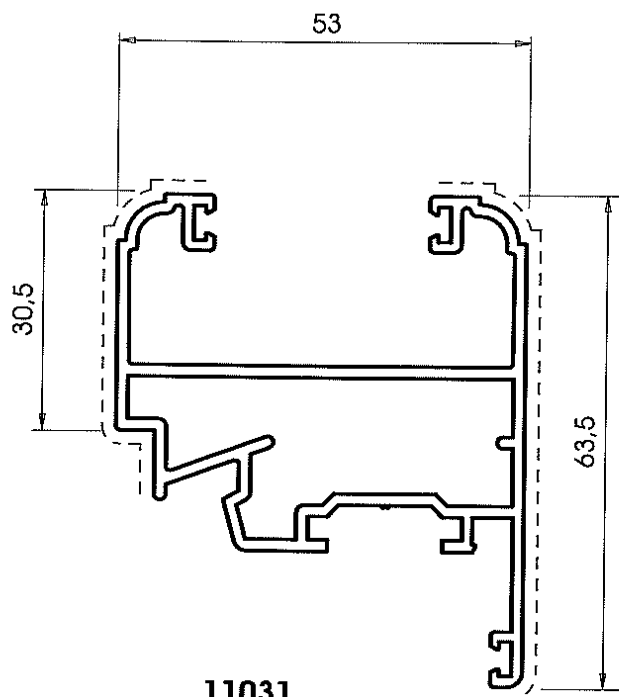

11031

peso Kg./mt. 1.121
sup. vista: mm. 134

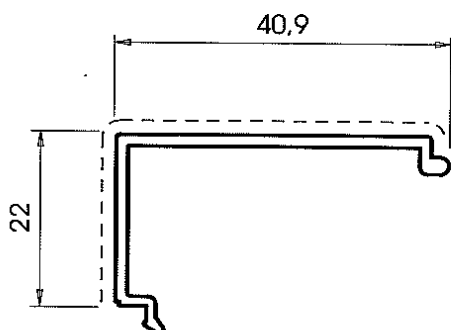

11044

peso Kg./mt. 0.300
sup. vista: mm. 63

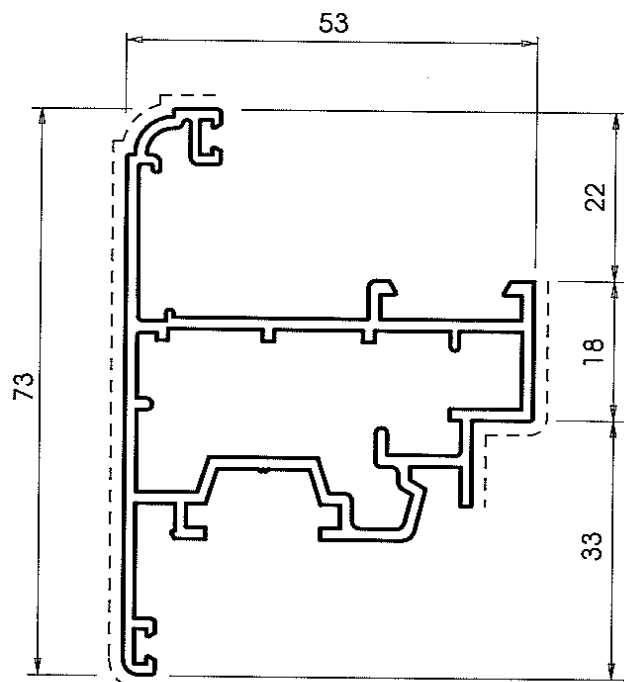

11032

peso Kg./mt. 1.142
sup. vista: mm. 123

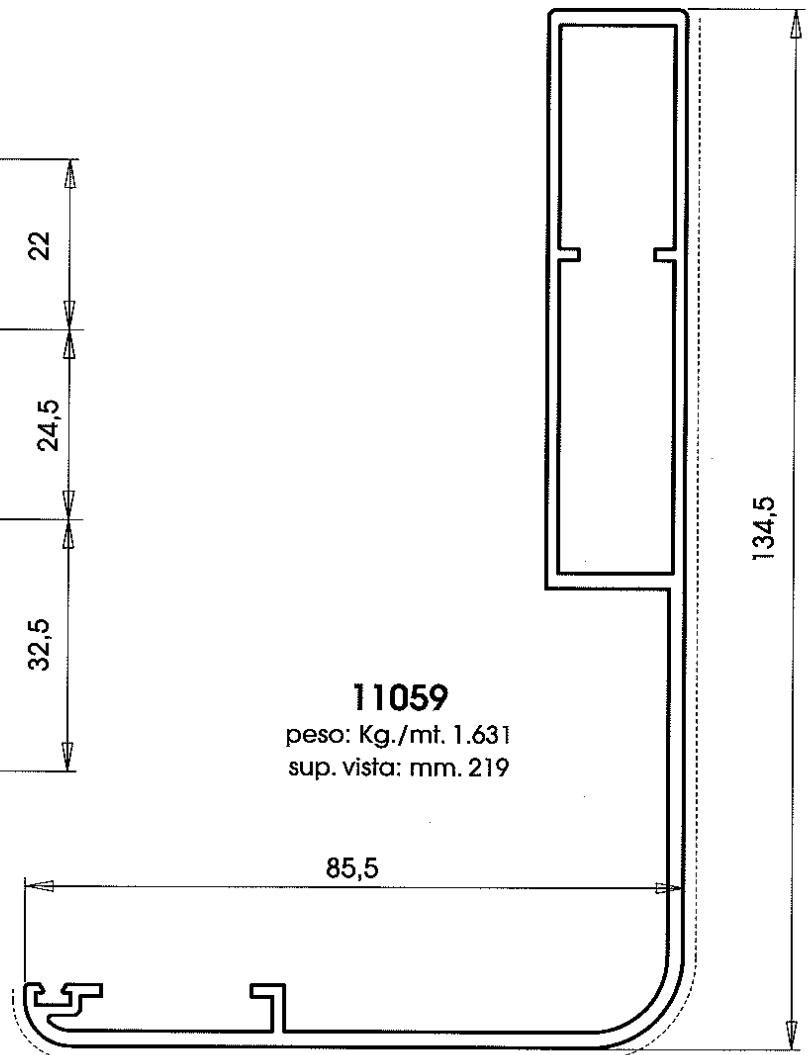
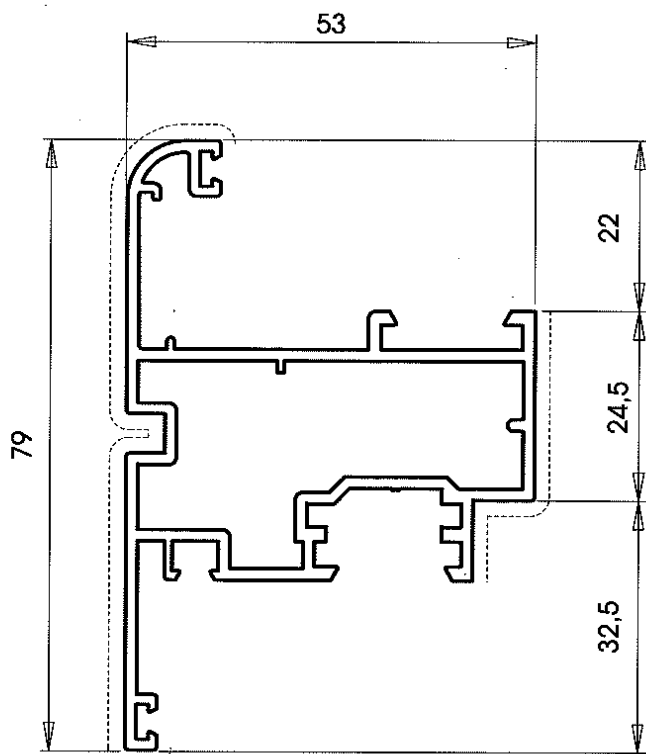
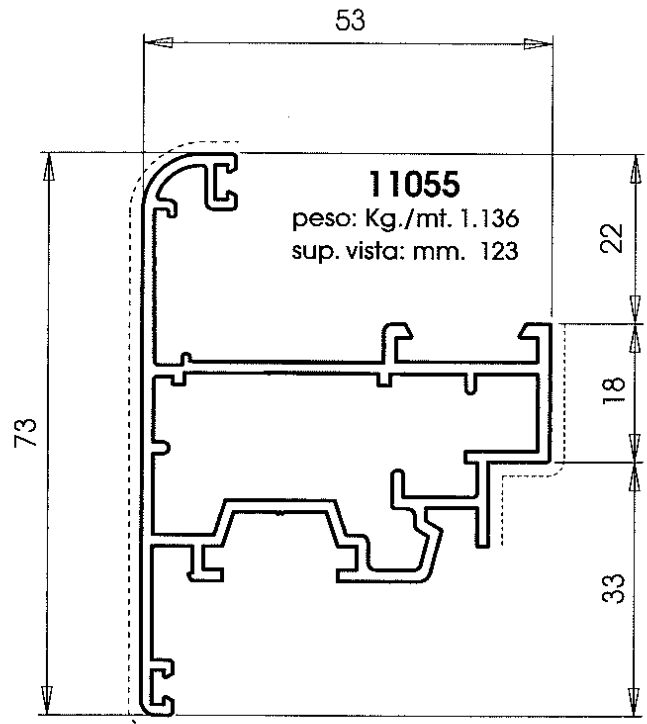
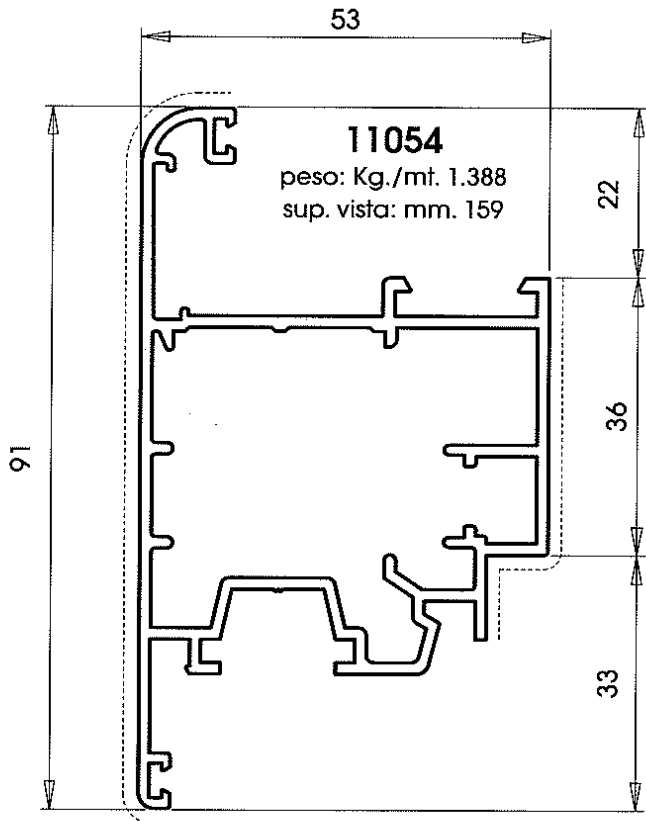

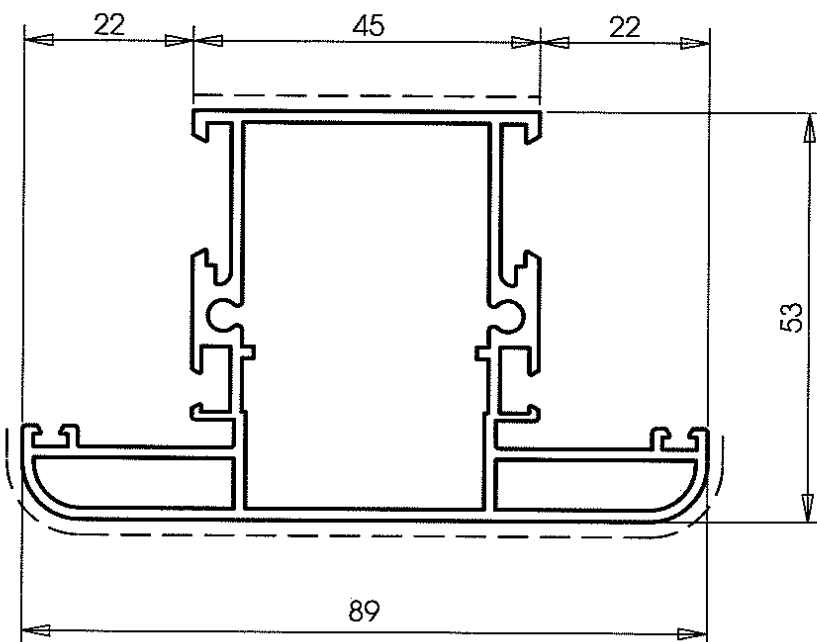
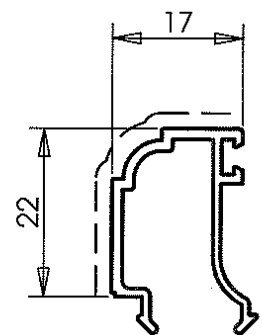
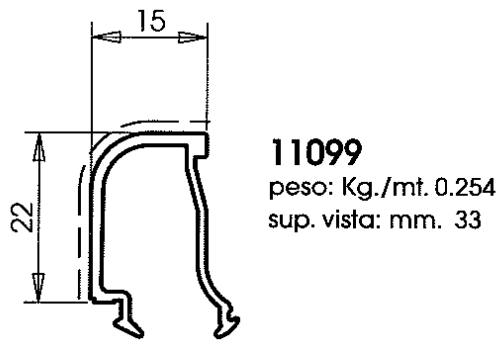
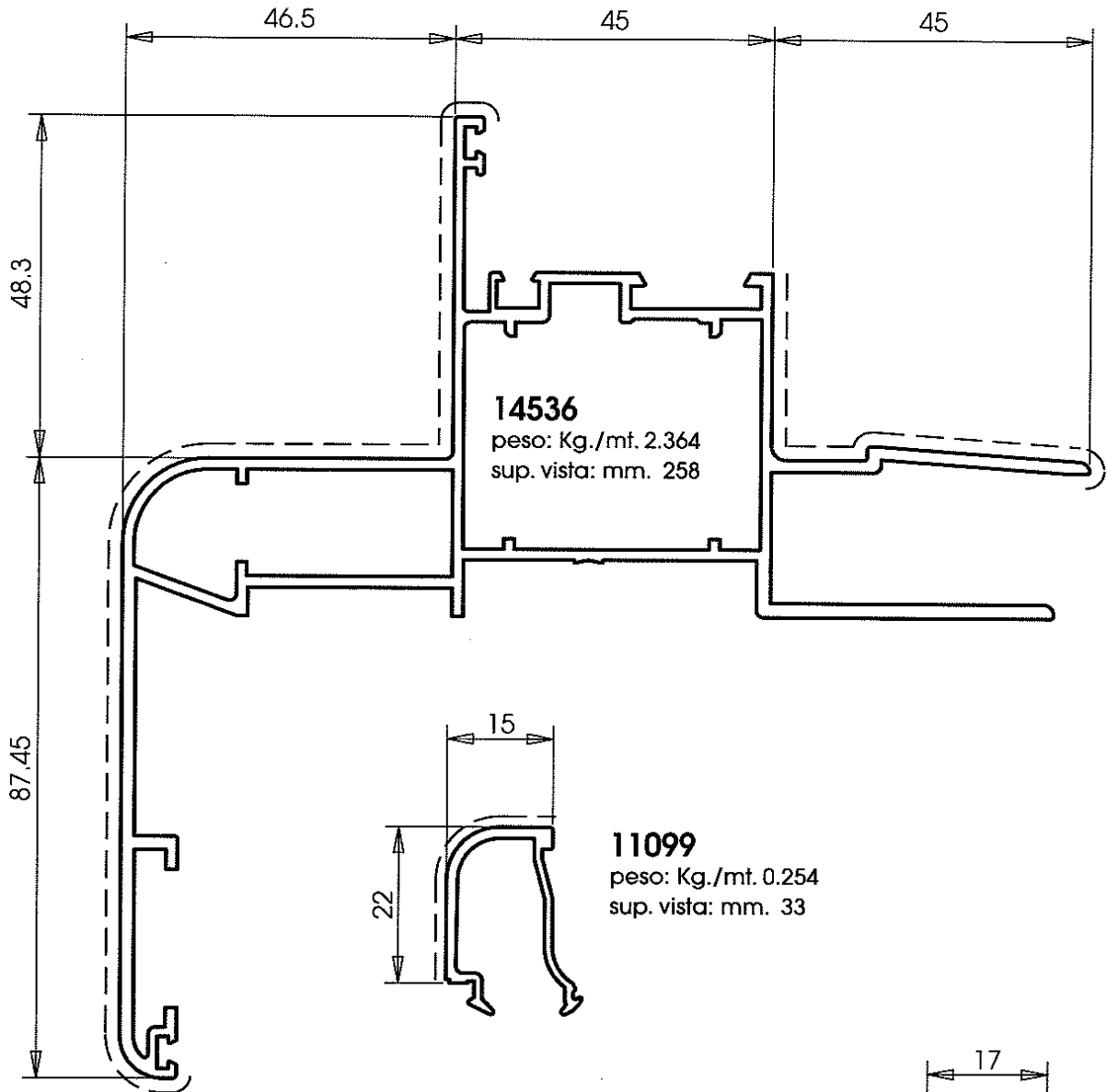

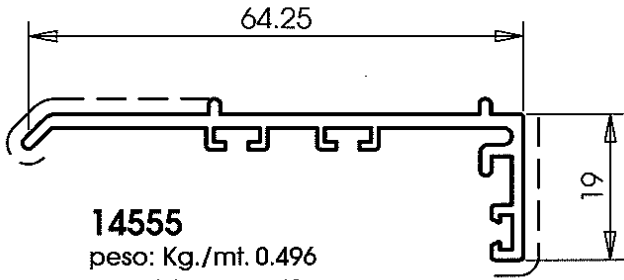

14555
peso: Kg./mt. 0.496
sup. vista: mm. 49

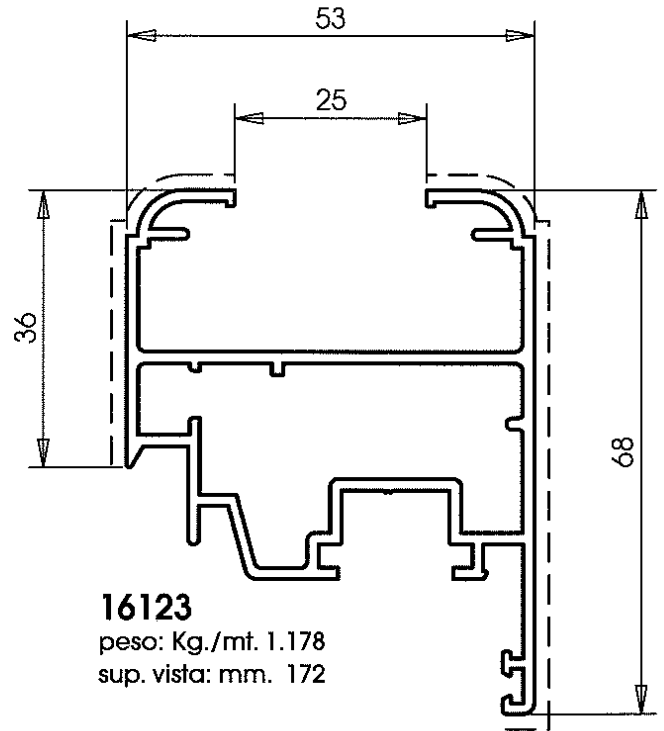

16123
peso: Kg./mt. 1.178
sup. vista: mm. 172

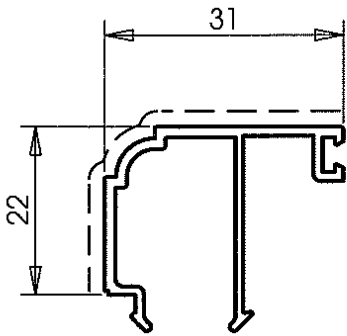

16307
peso: Kg./mt. 0.311
sup. vista: mm. 49

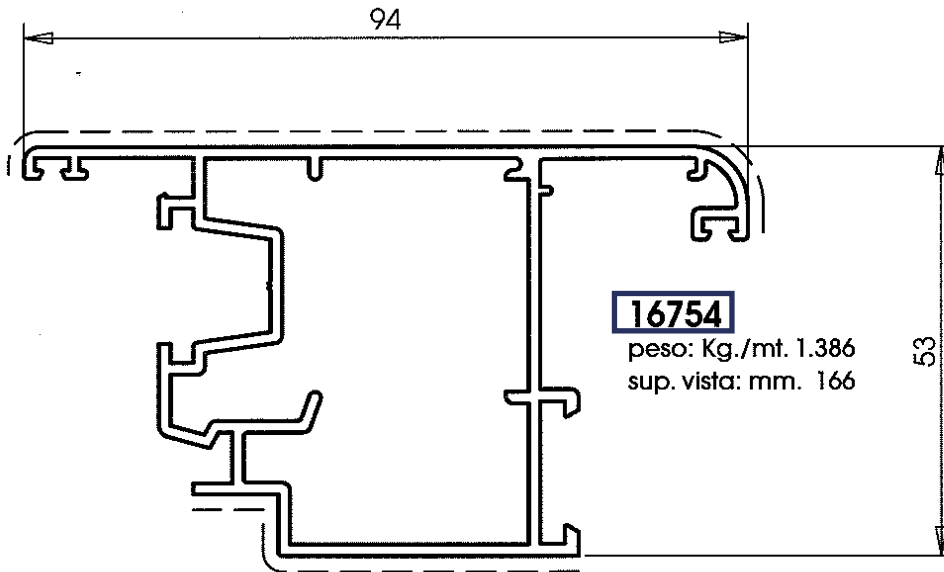

16754
peso: Kg./mt. 1.386
sup. vista: mm. 166

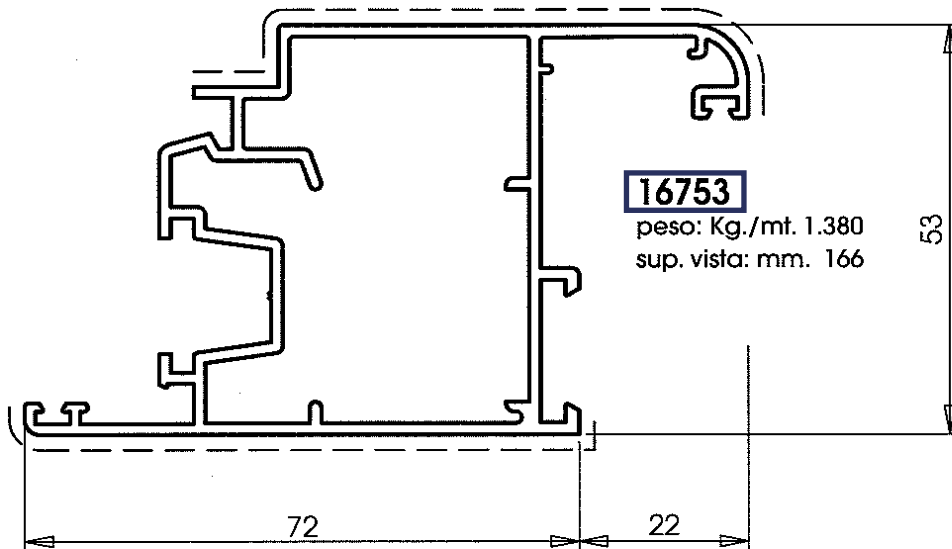

16753
peso: Kg./mt. 1.380
sup. vista: mm. 166

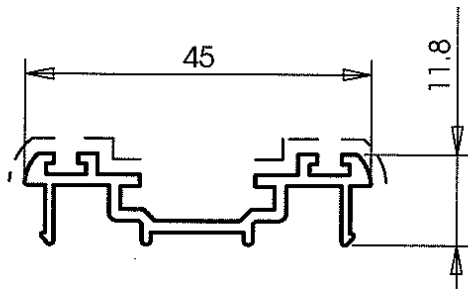

16802
peso: Kg./mt. 0.358
sup. vista: mm. 34

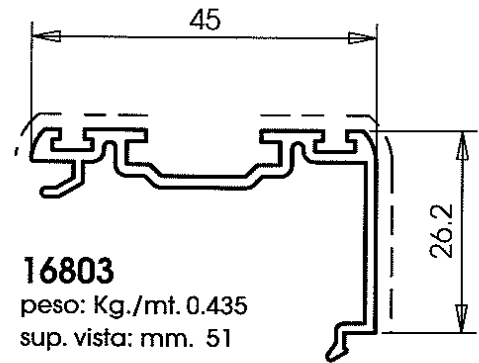

16803
peso: Kg./mt. 0.435
sup. vista: mm. 51

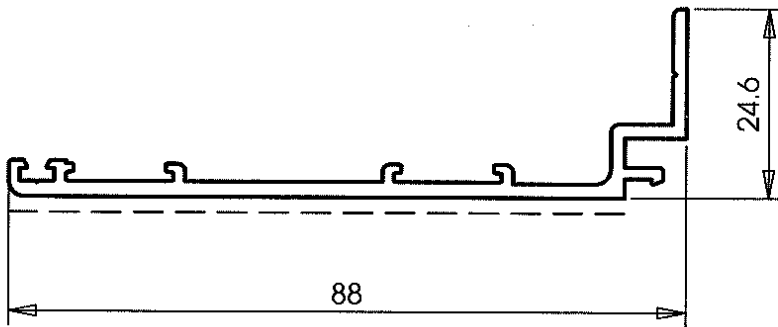

16805
peso: Kg./mt. 0.658
sup. vista: mm. 78

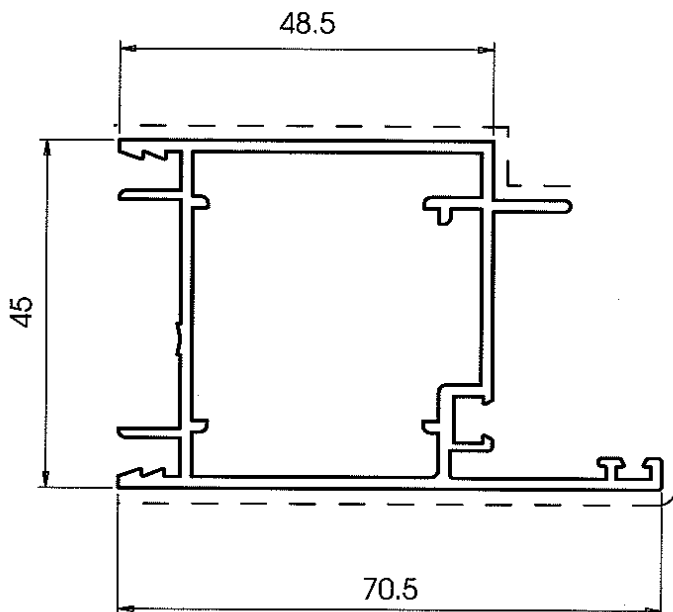

16811
peso: Kg./mt. 1.061
sup. vista: mm. 139

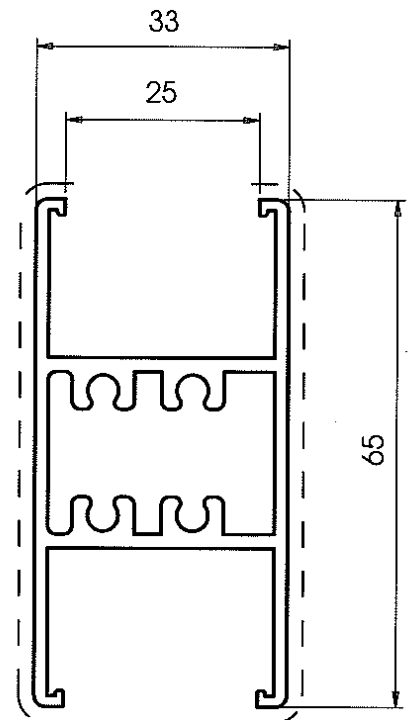

16810
peso: Kg./mt. 1.166
sup. vista: mm. 142

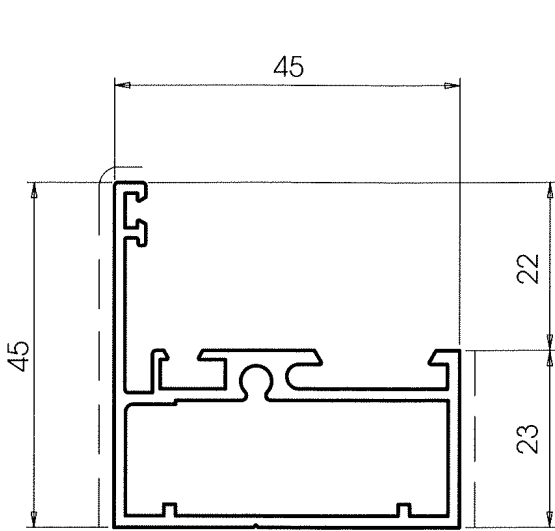

16818

peso: Kg./mt. 0.782
sup. vista: mm. 71

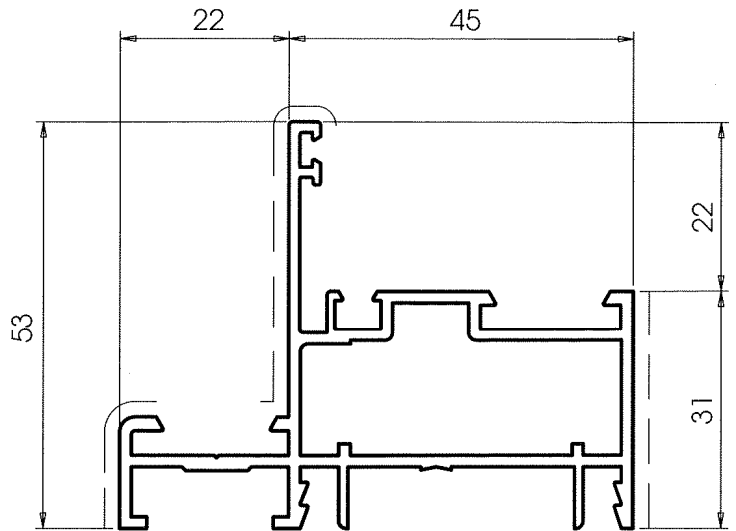

16819

peso: Kg./mt. 1.058
sup. vista: mm. 93

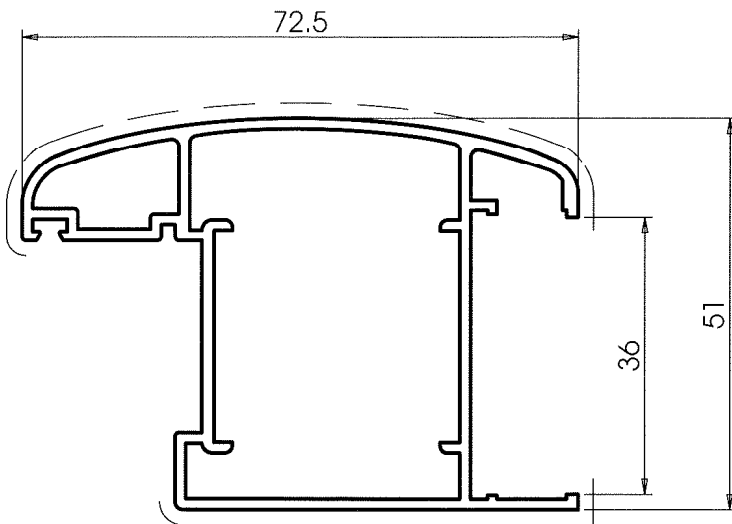

19705

peso: Kg./mt. 1.083
sup. vista: mm. 142

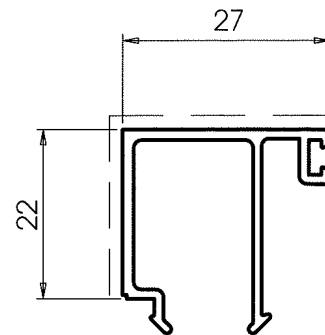

11084

peso: Kg./mt. 0.316
sup. vista: mm. 49

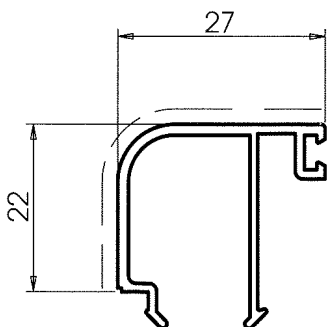

16808

peso: Kg./mt. 0.294
sup. vista: mm. 45

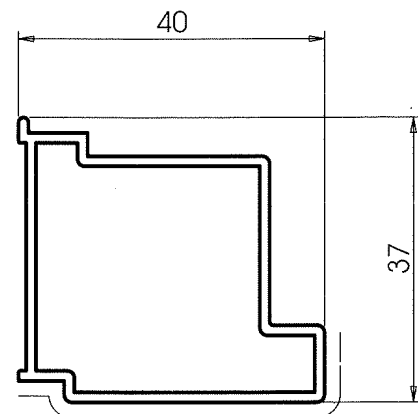

19706

peso: Kg./mt. 0.511
sup. vista: mm. 51

19715LV

peso: Kg./mt. 0.258
sup. vista: mm. 34

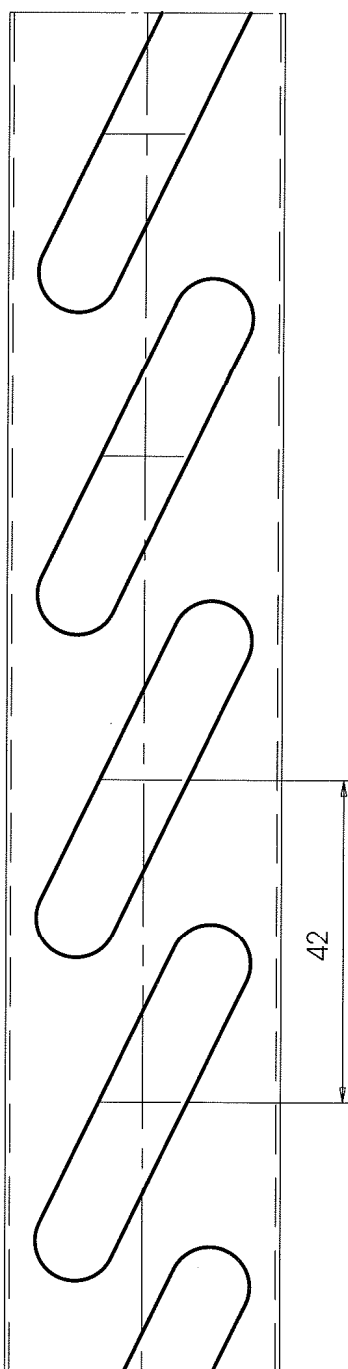
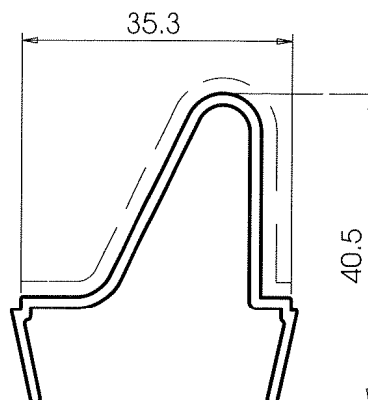
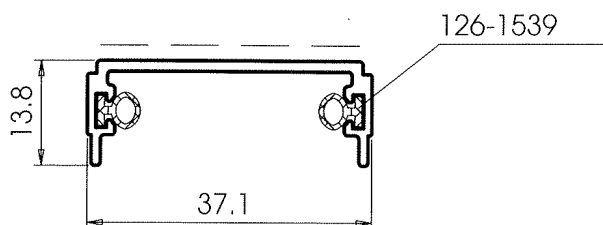

19716

peso: Kg./mt. 0.399
sup. vista: mm. 74

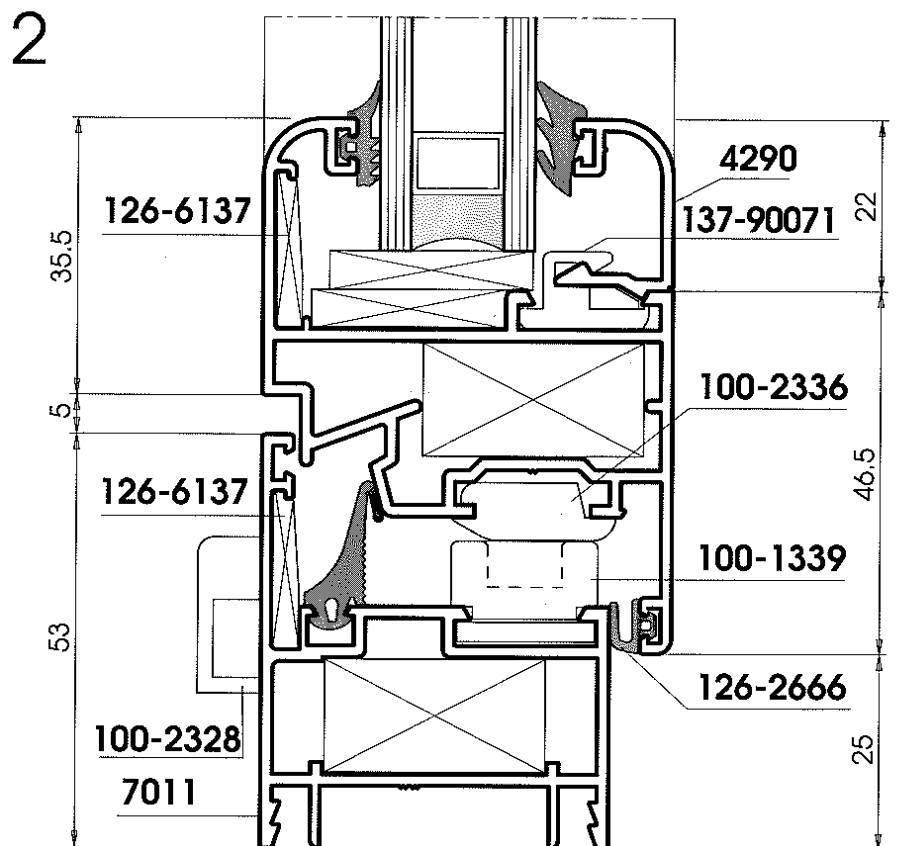
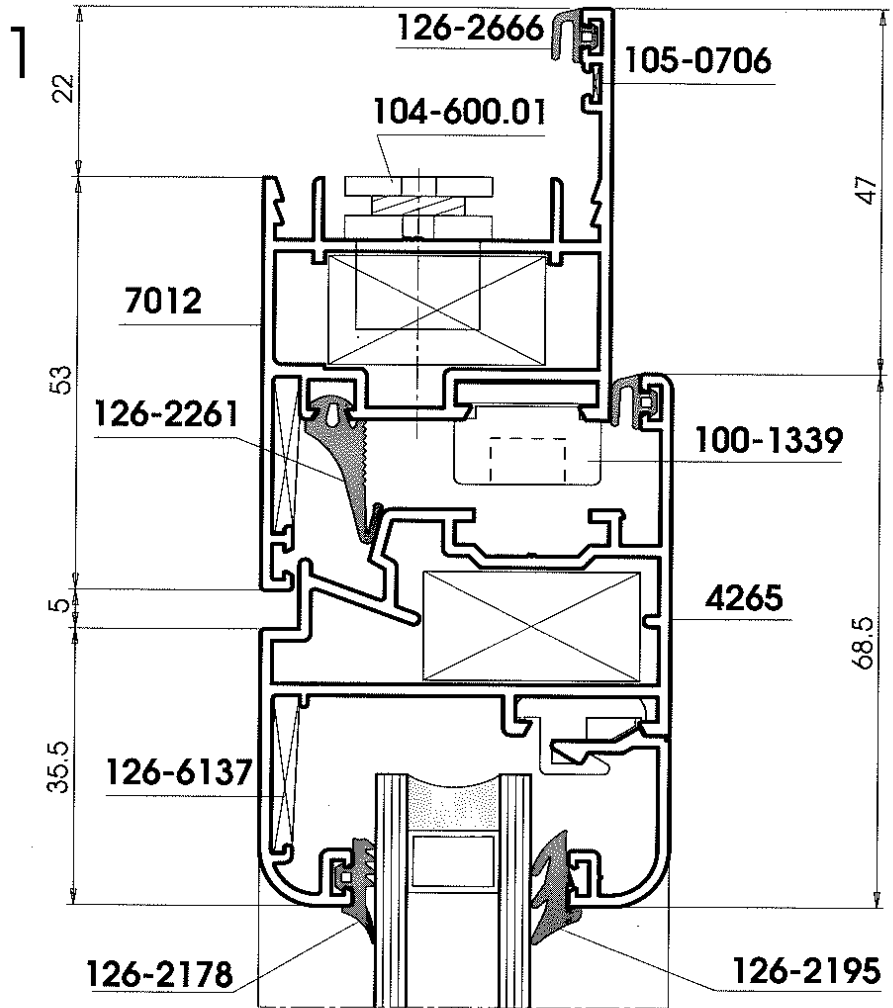
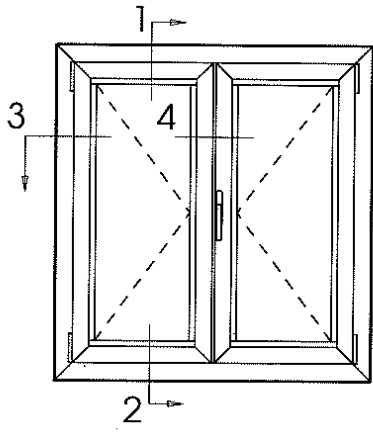

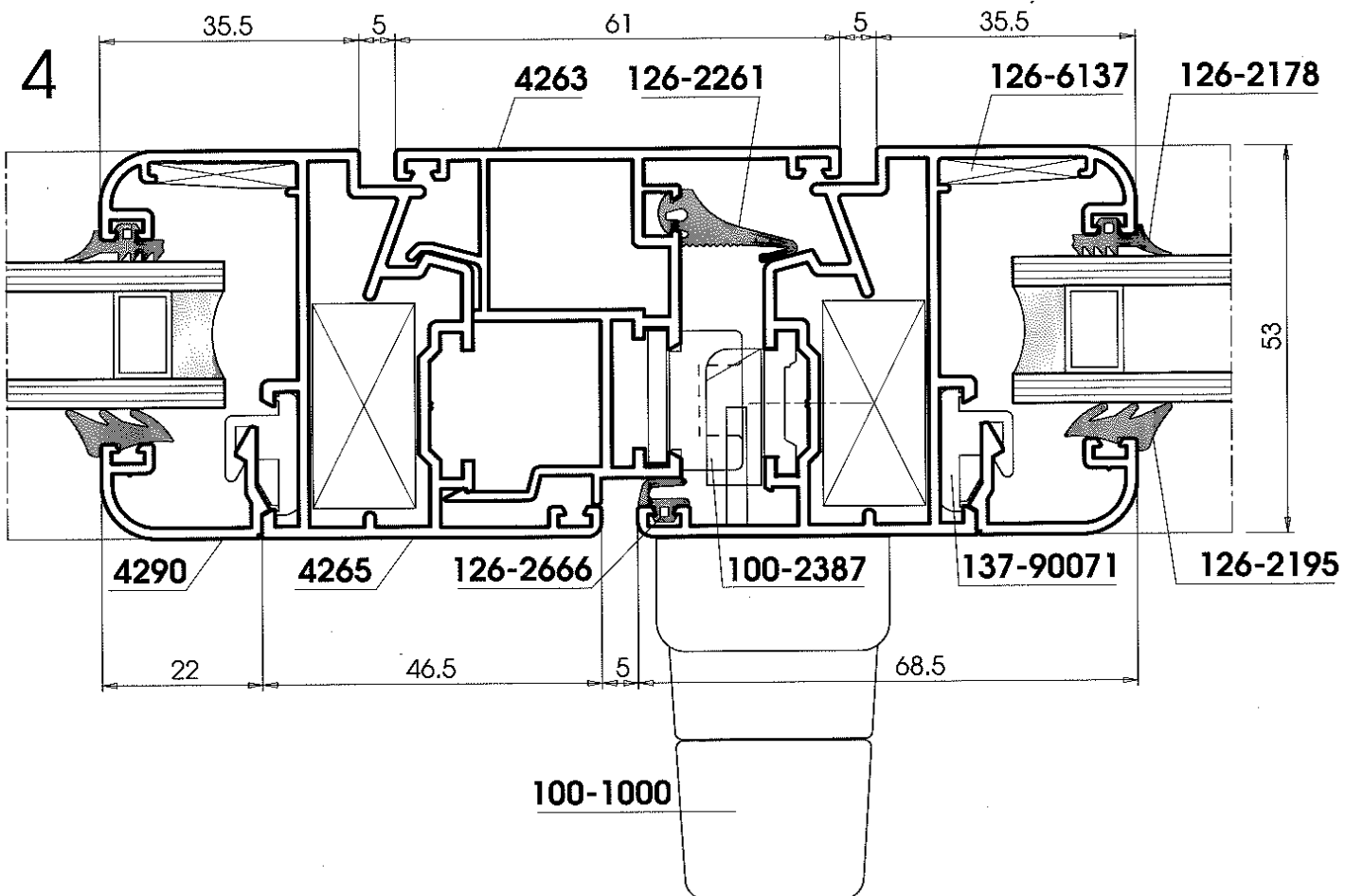
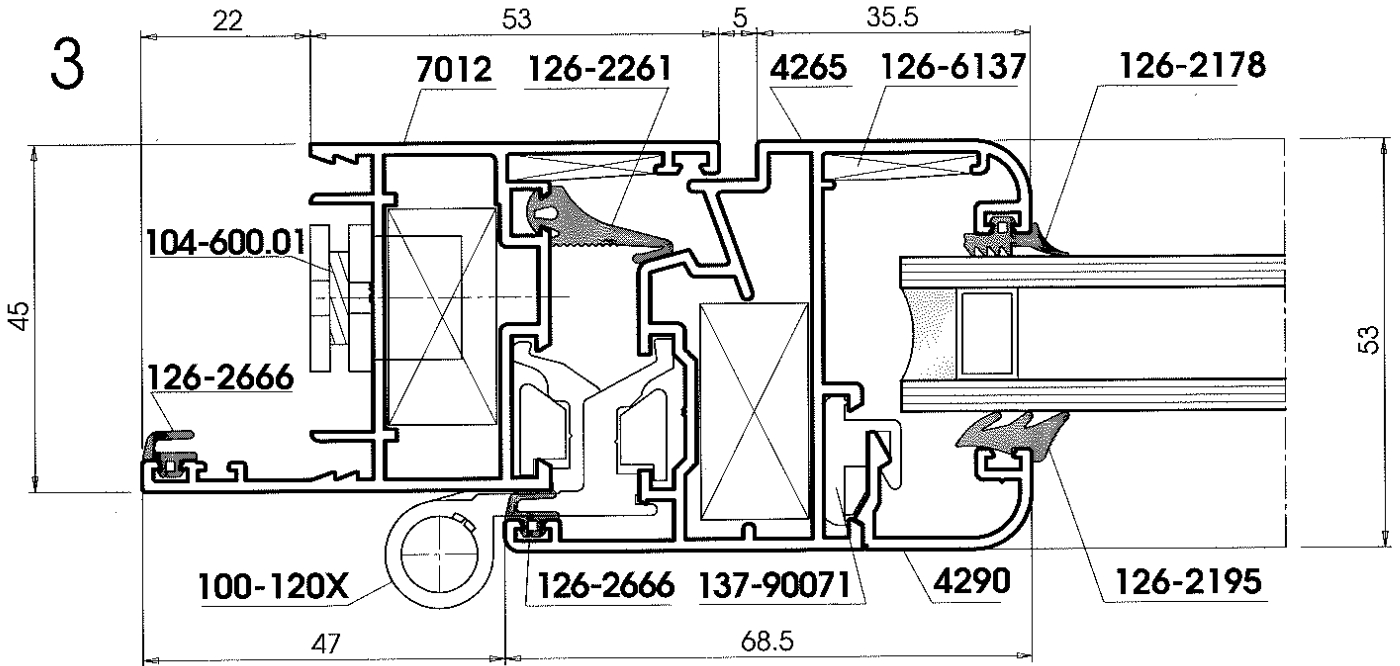

FINESTRA APERTURA ESTERNA
CASEMENT WINDOW EXTERNAL OPENING

50
 SETTEMBRE '96

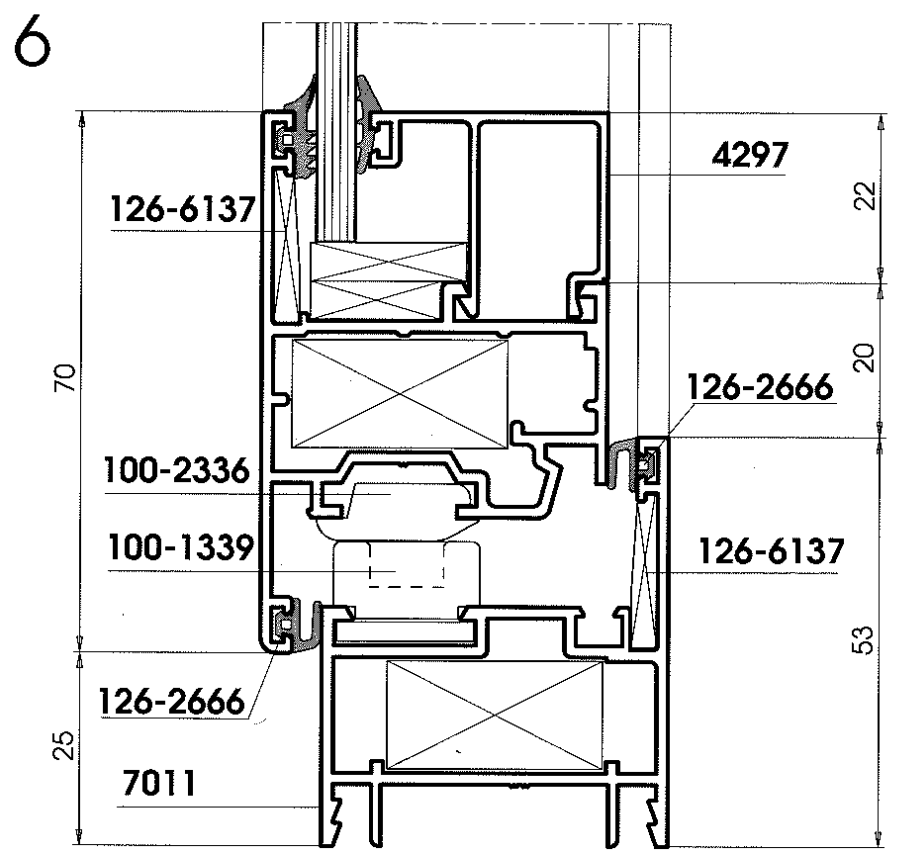
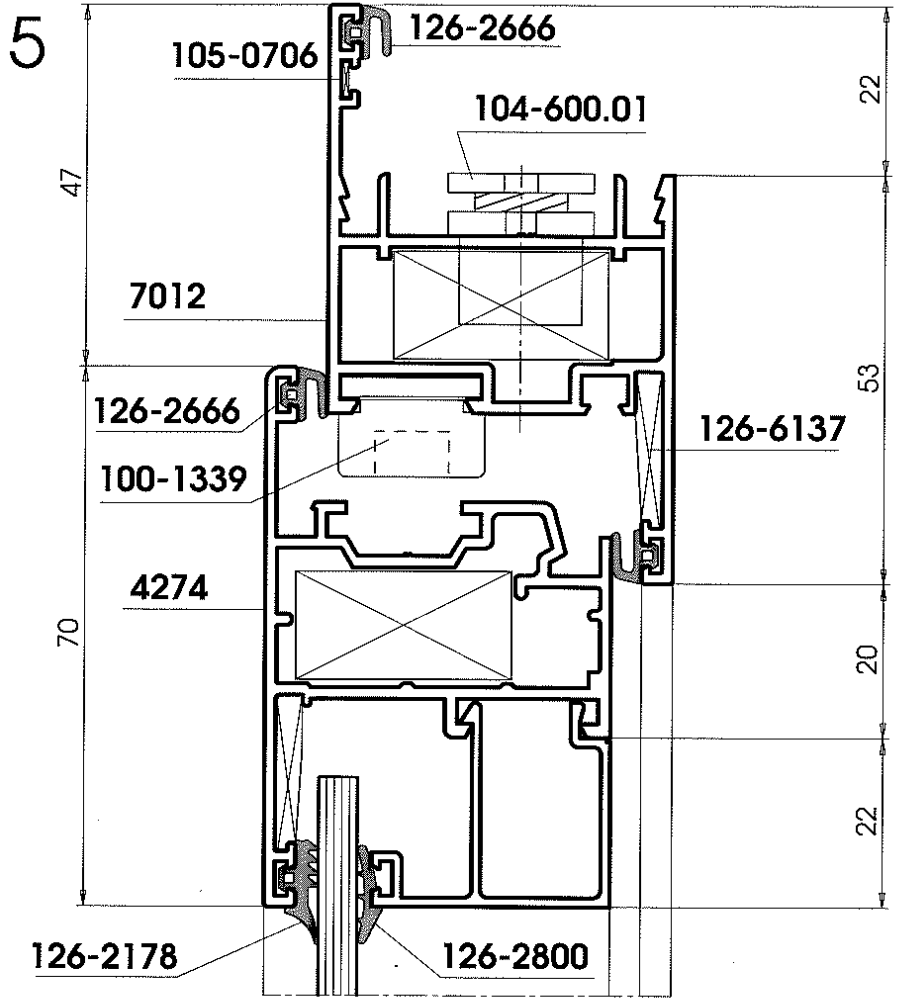
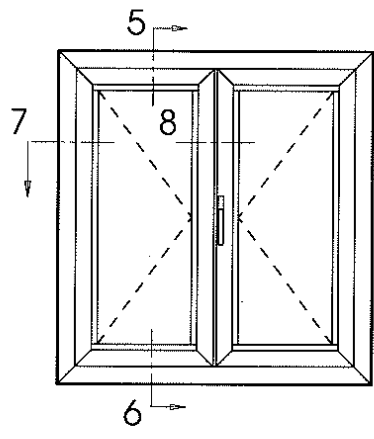

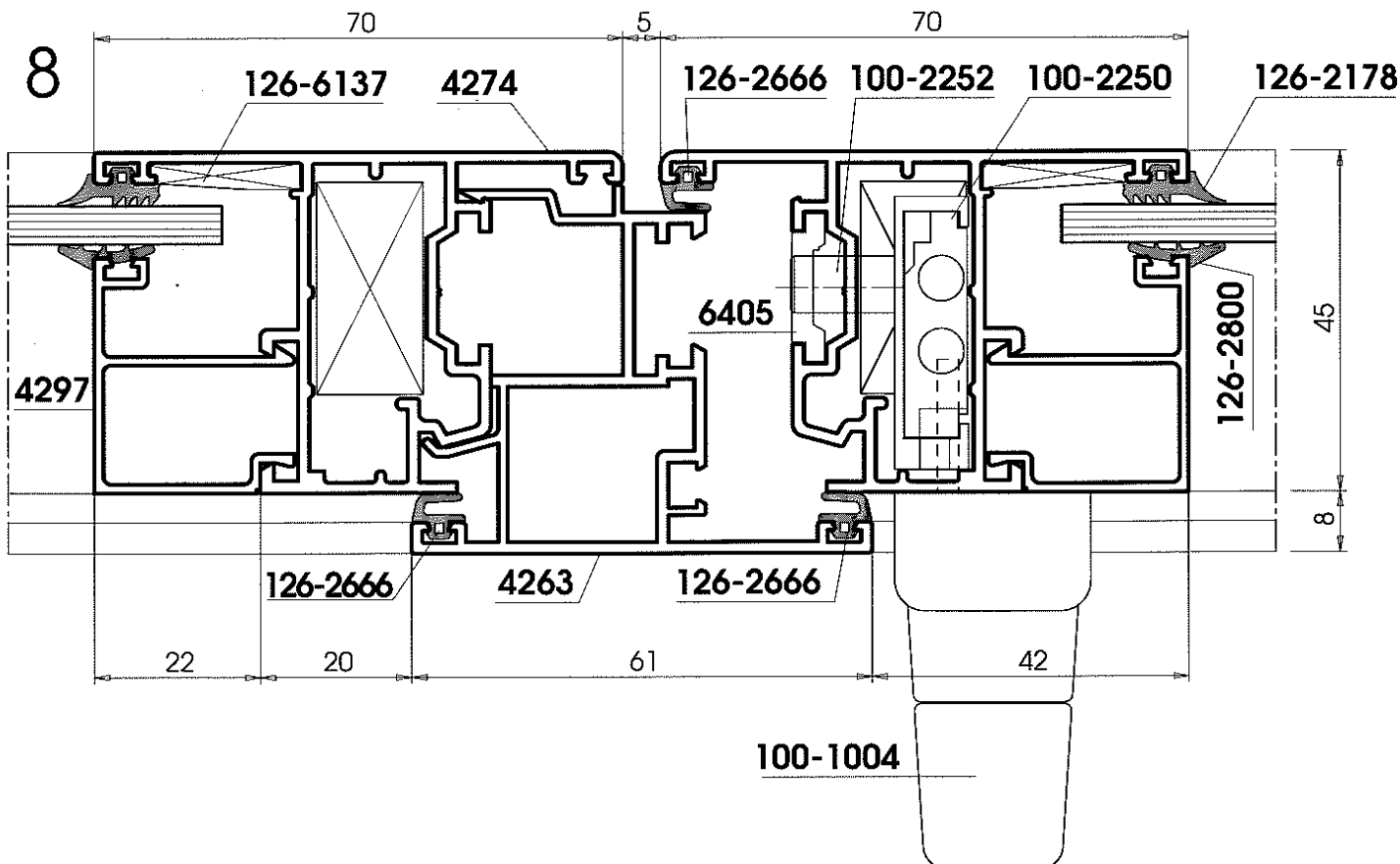
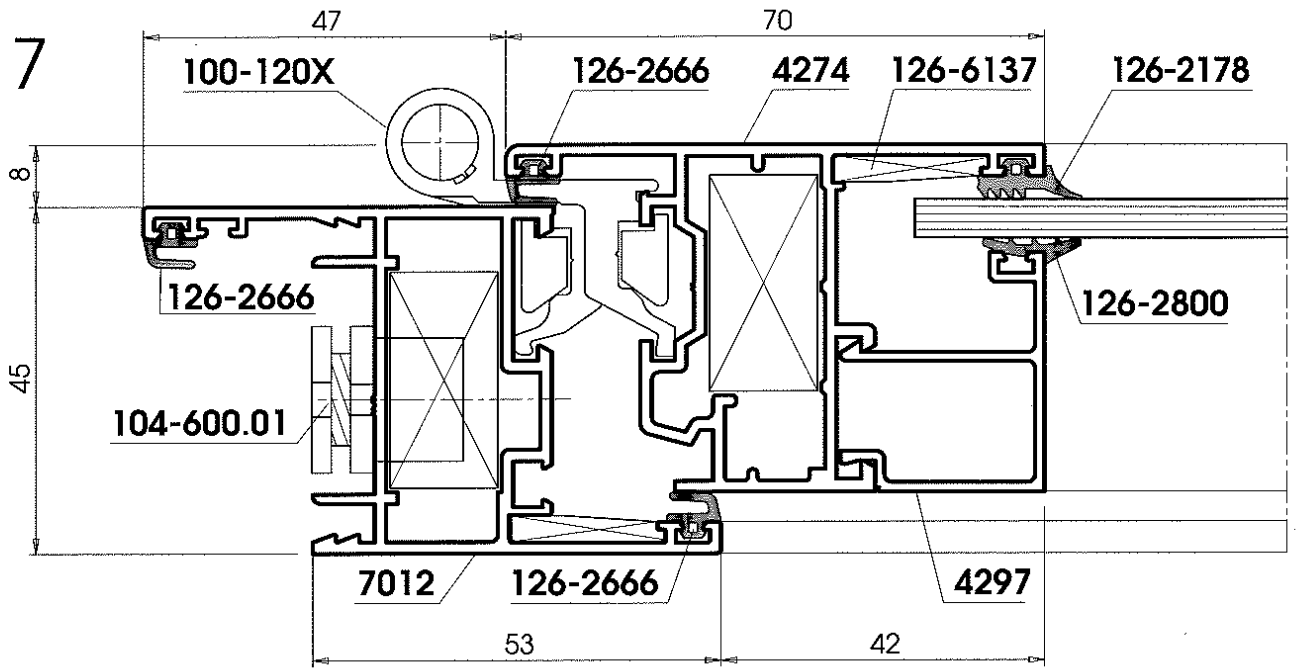

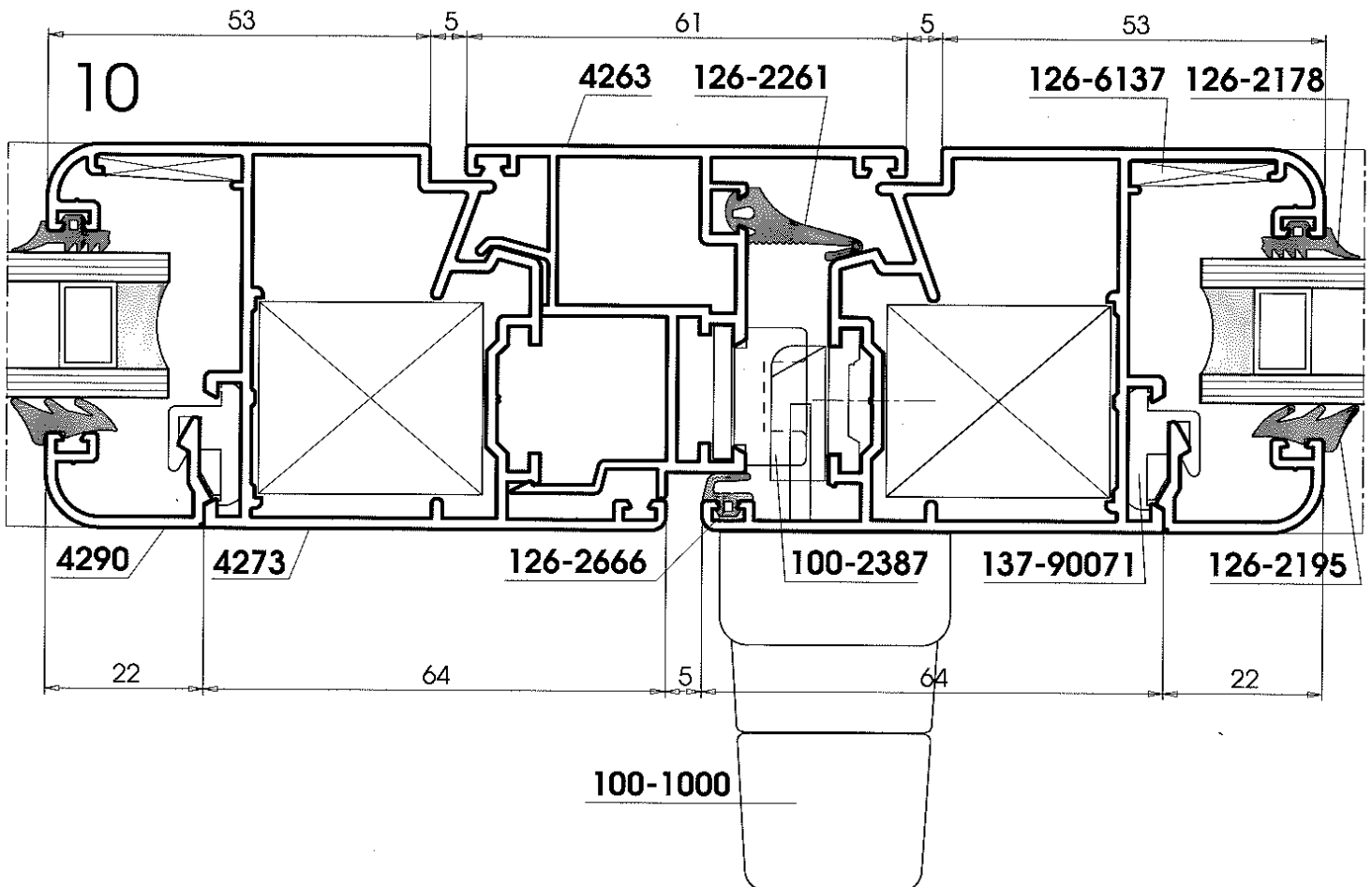
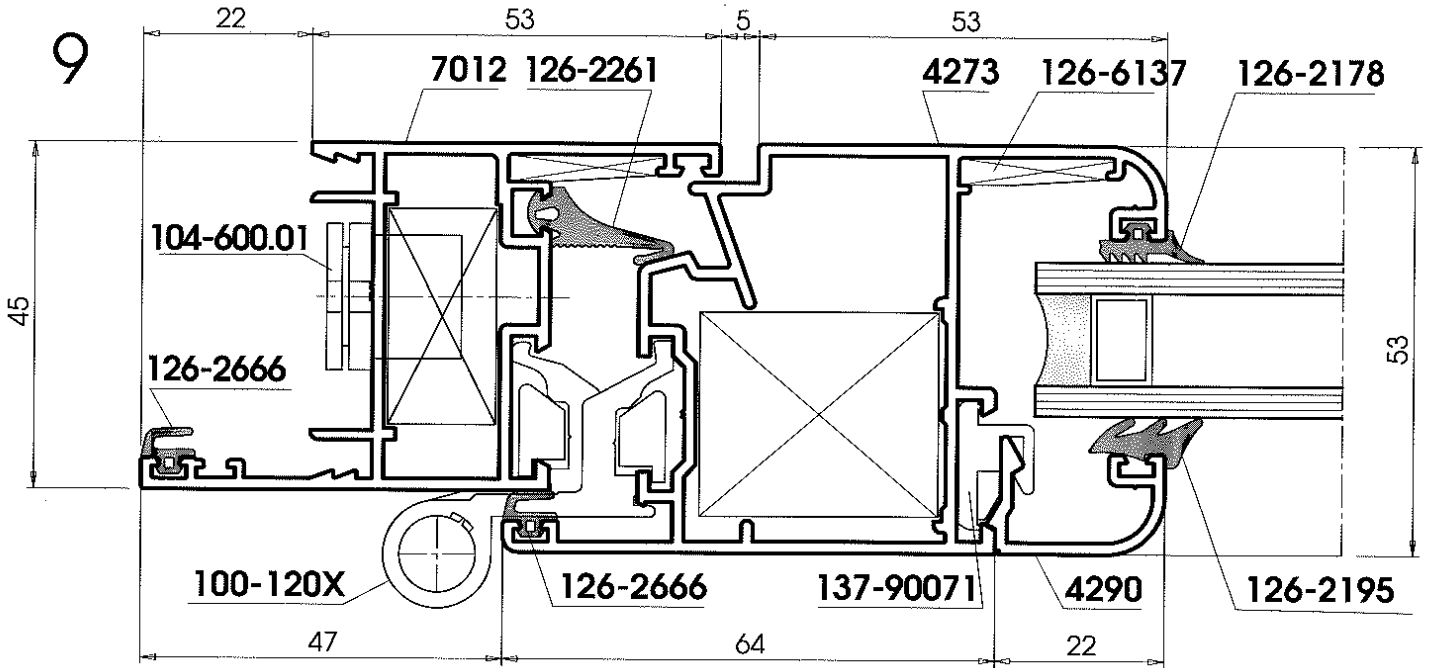
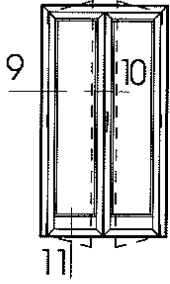

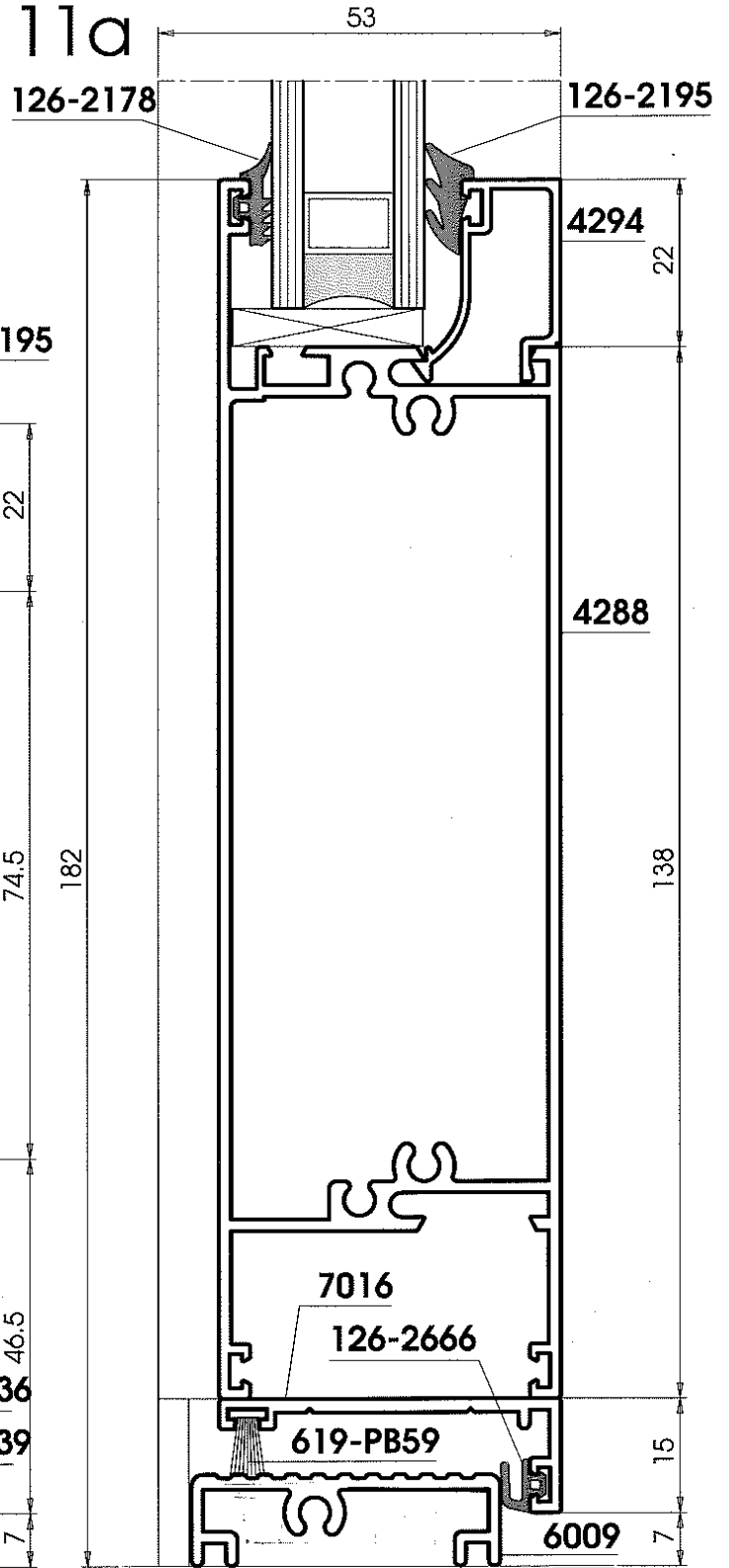
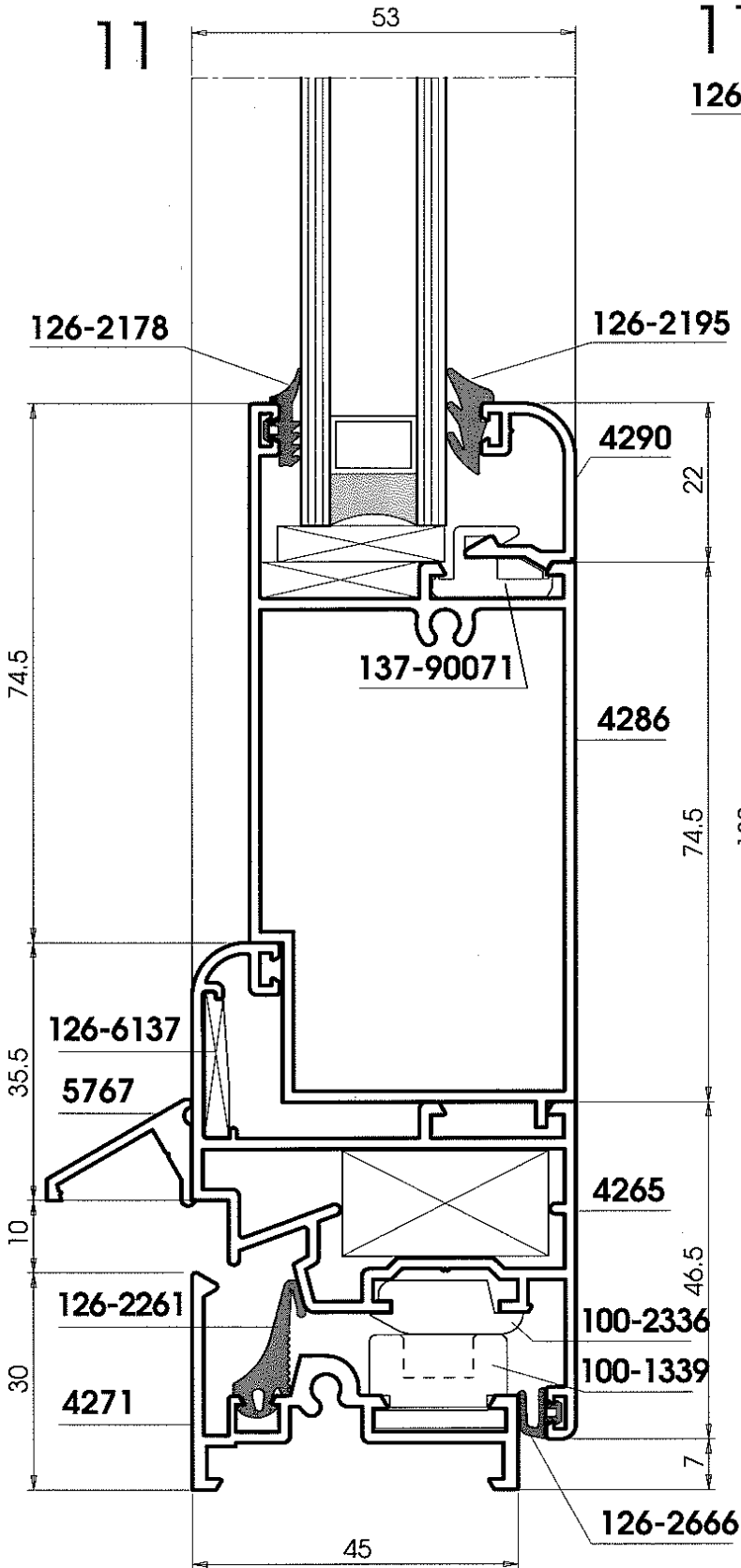

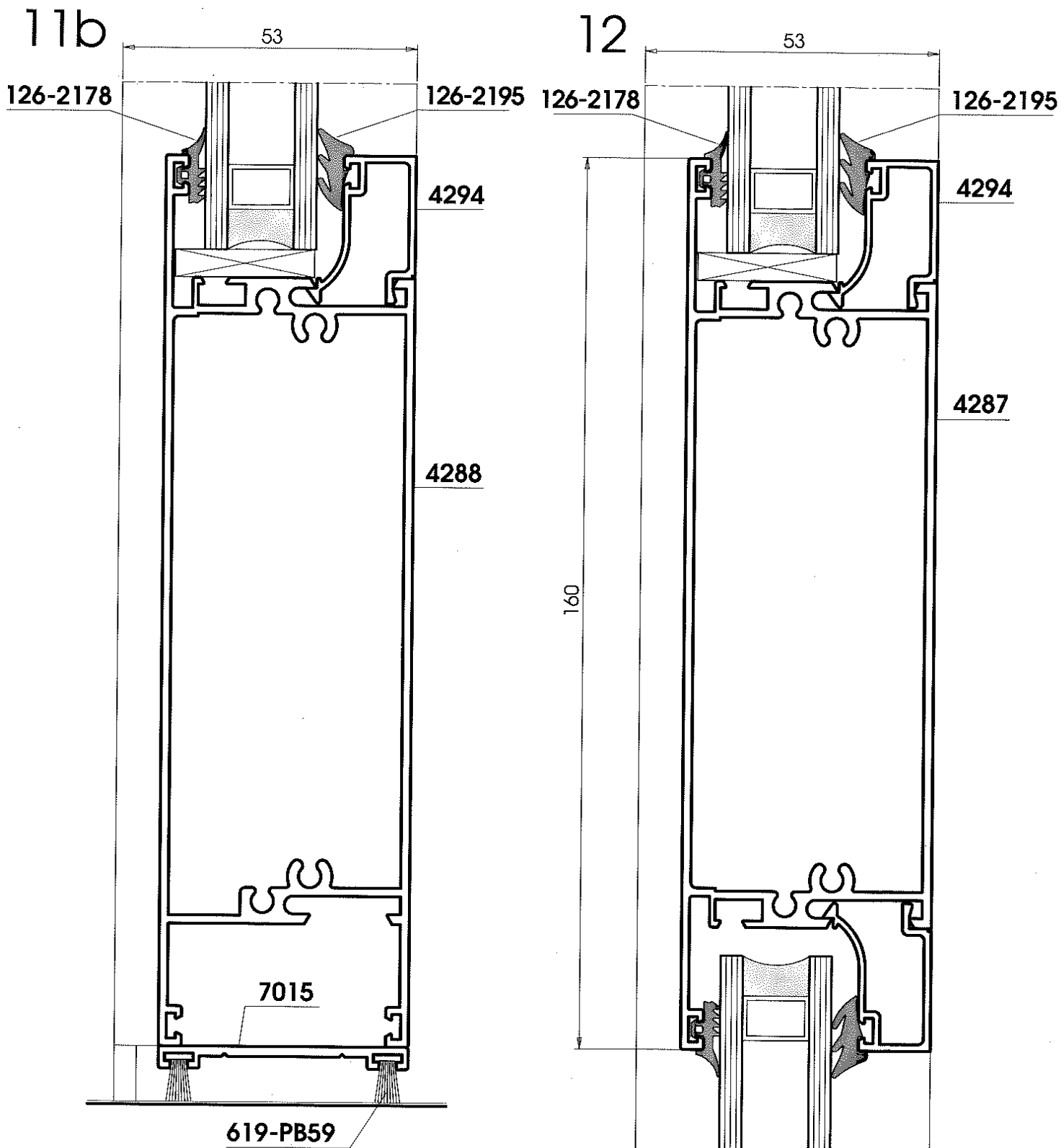
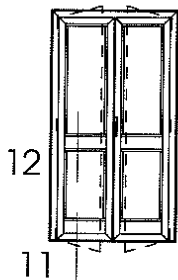

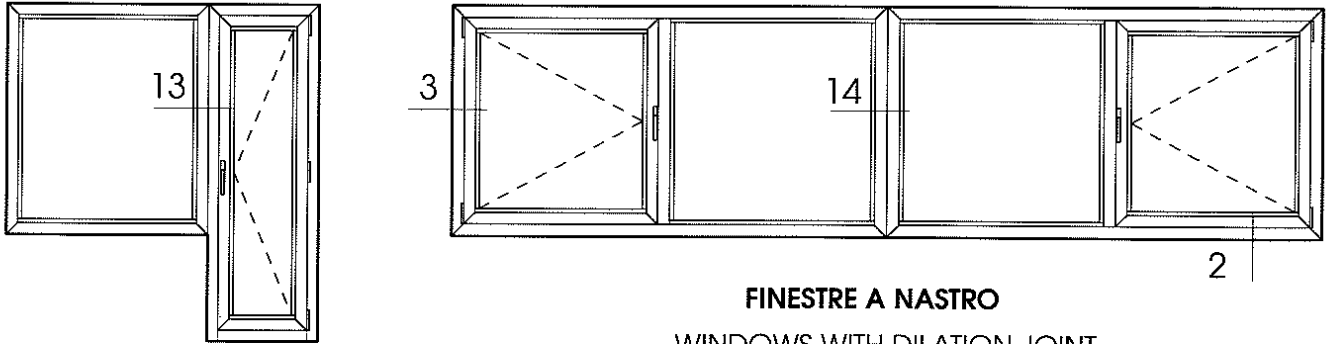

FINESTRE A NASTRO

WINDOWS WITH DILATION JOINT

GIUNZIONE DI DUE SERRAMENTI
JOINT OF TWO WINDOWS FRAMING

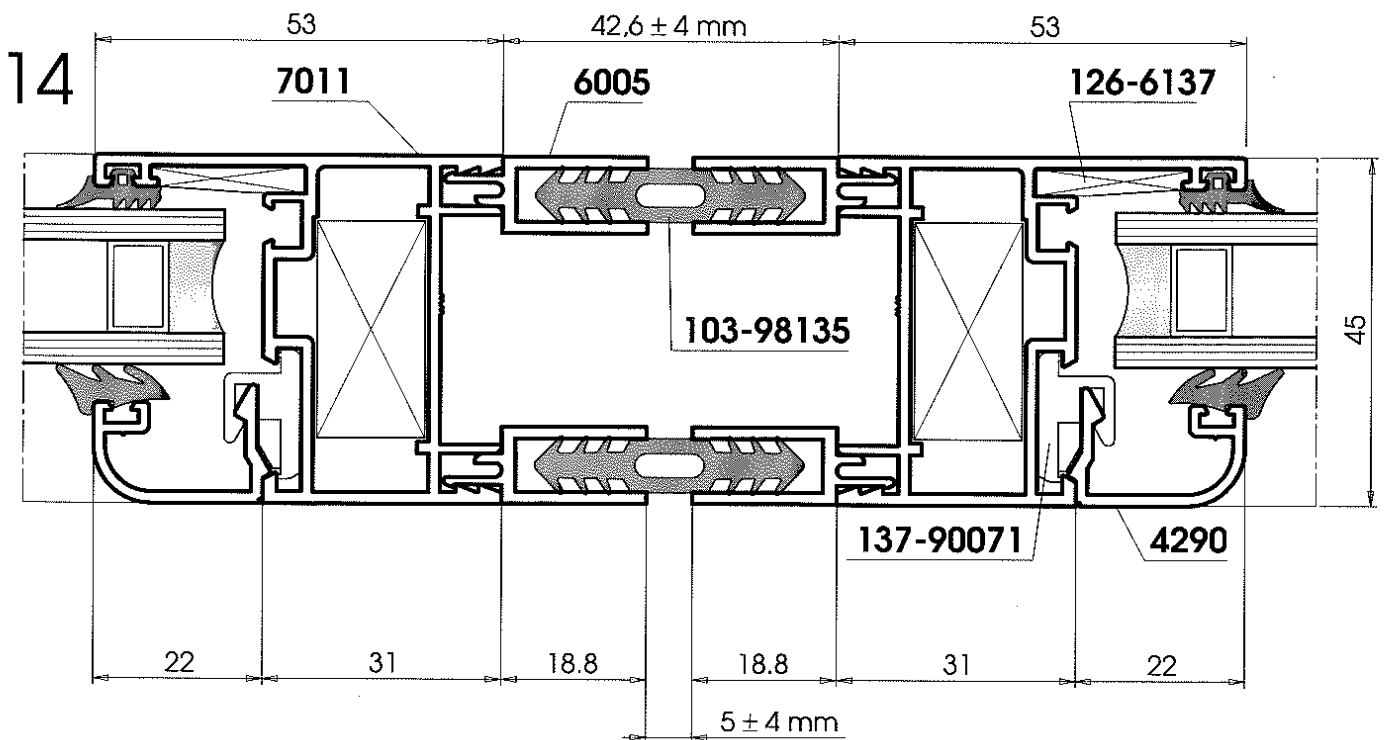
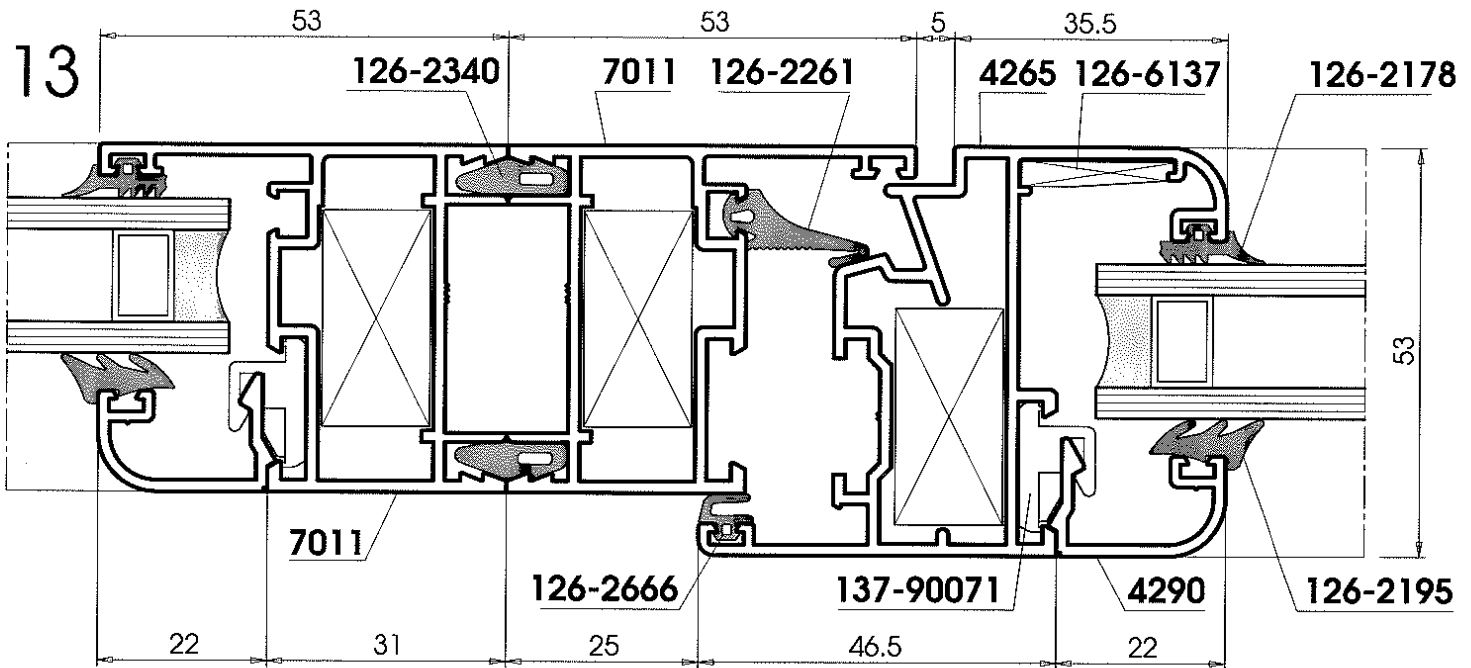

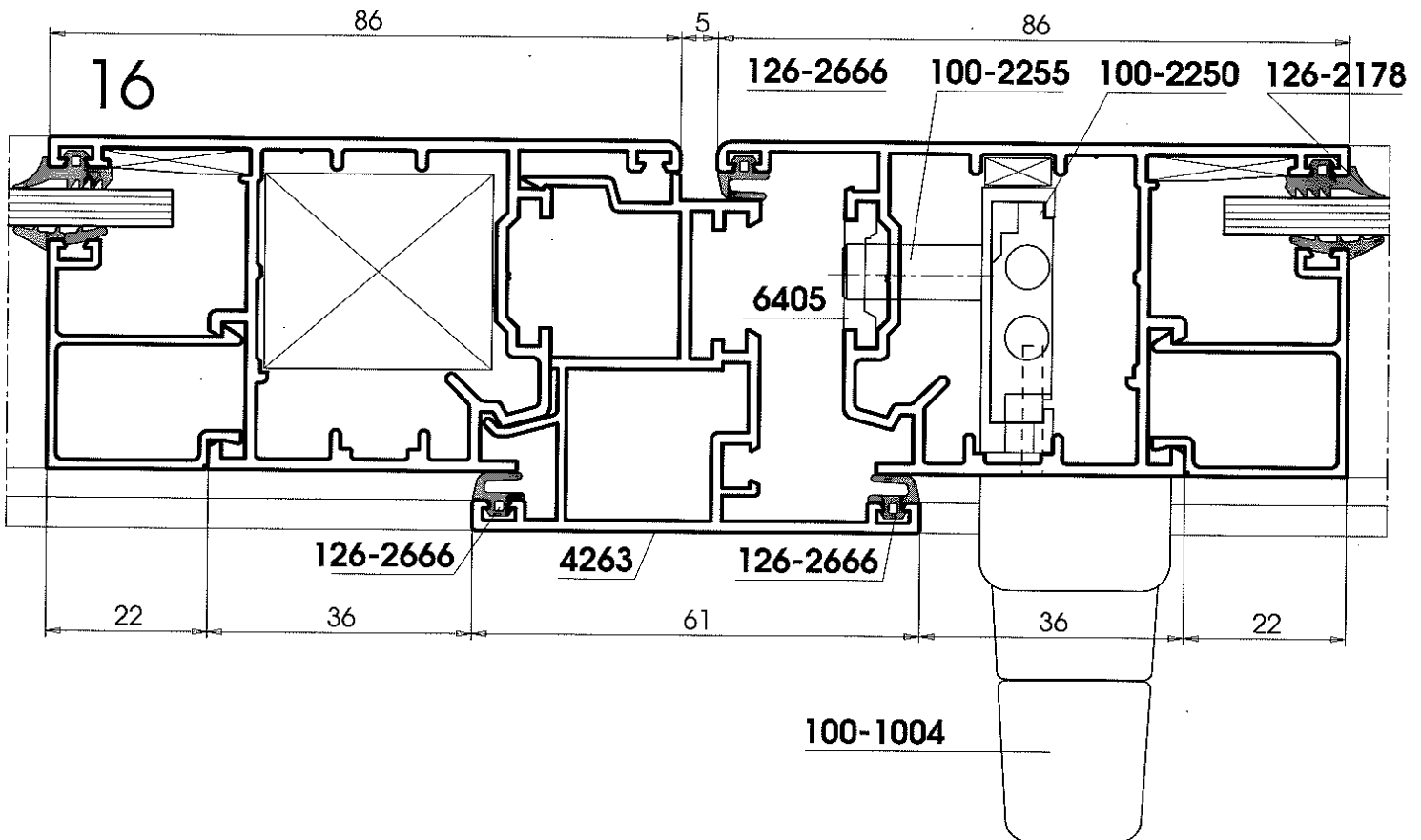
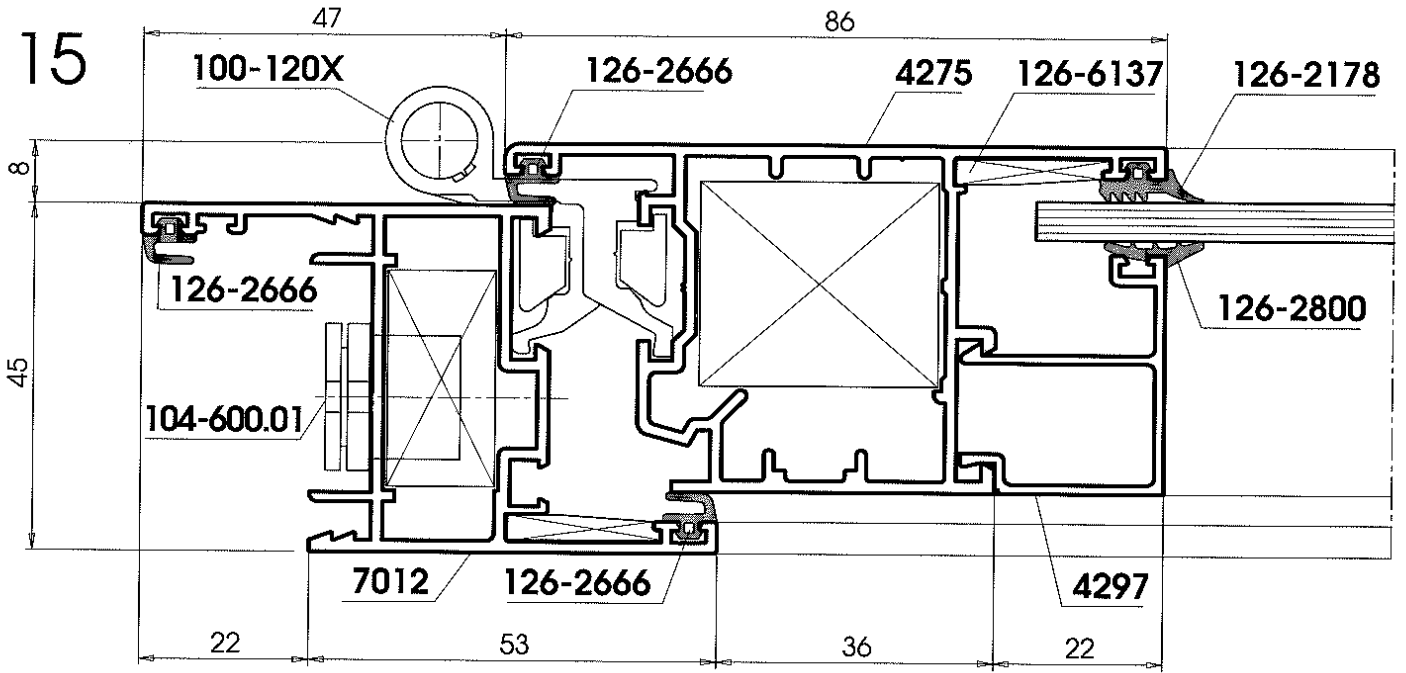
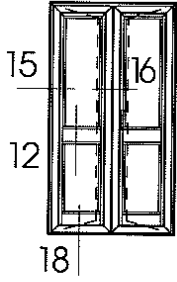

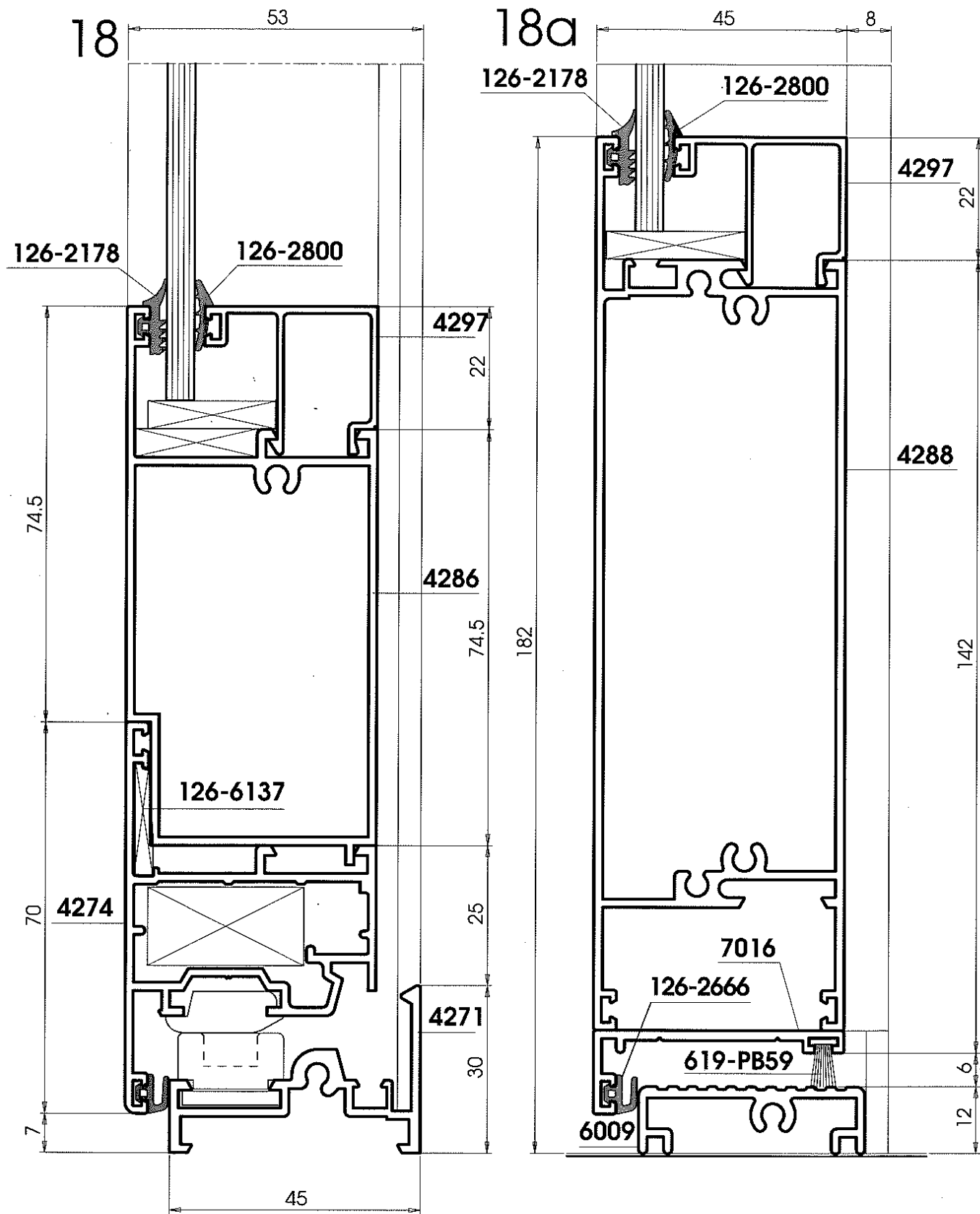

PORTA CON APERTURA INTERNA
DOOR WITH INTERNAL OPENING

58
 SETTEMBRE '96

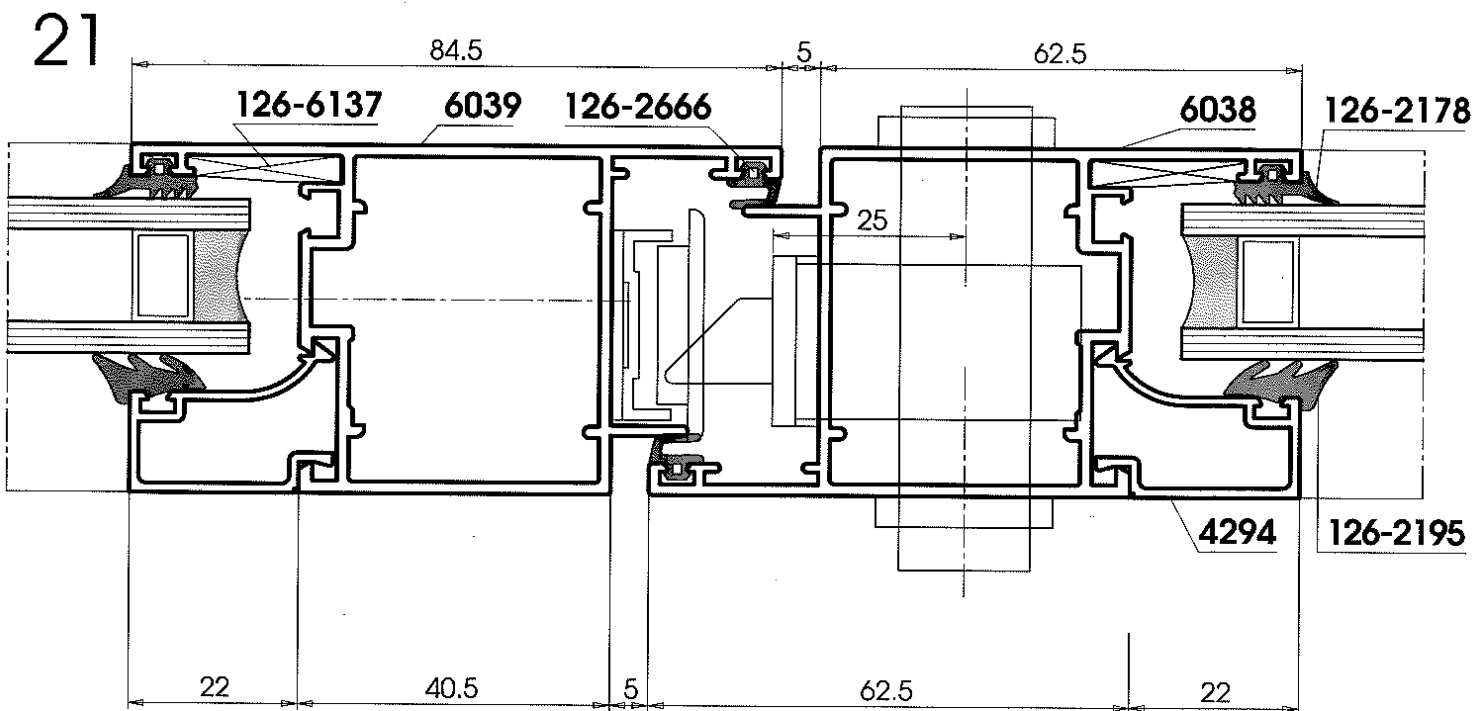
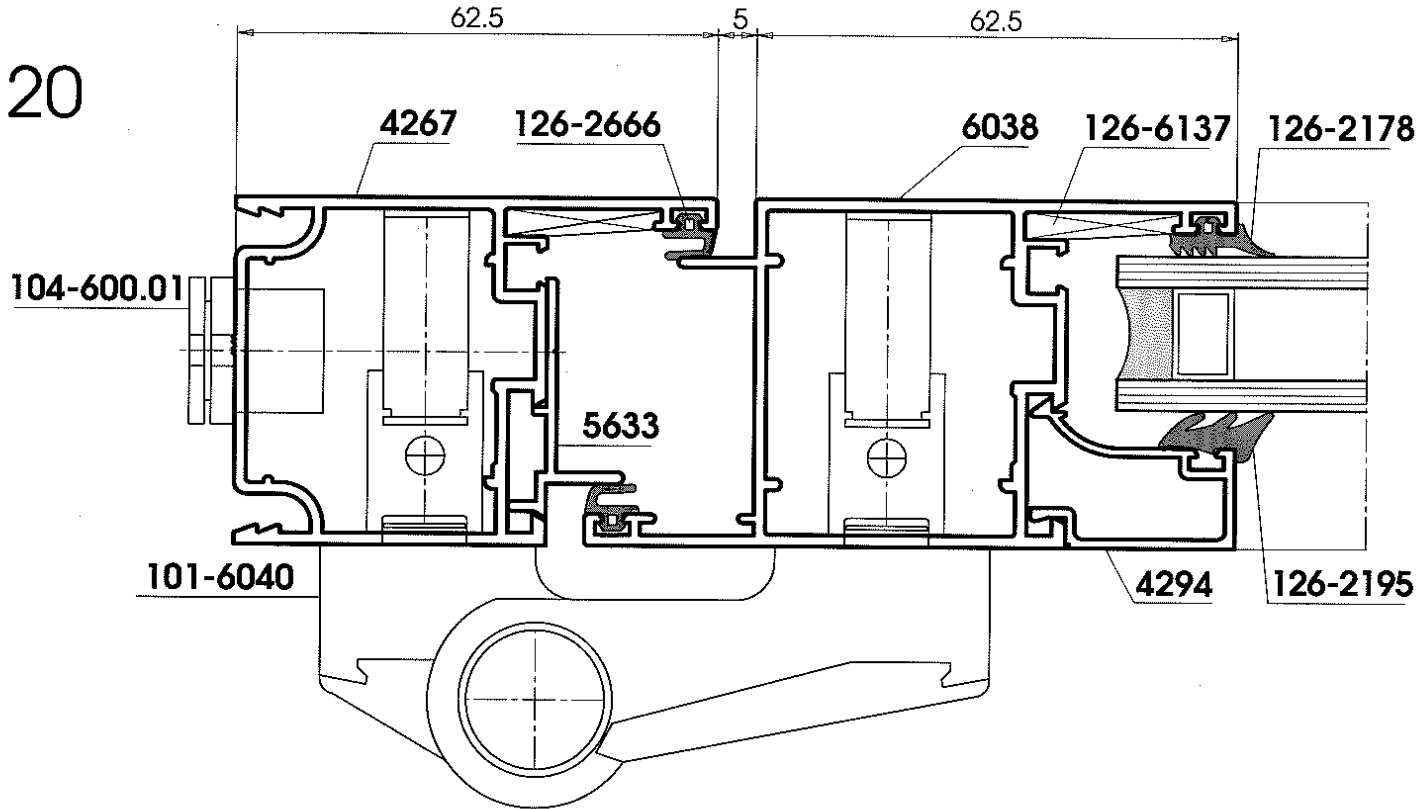
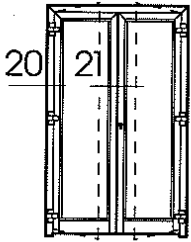

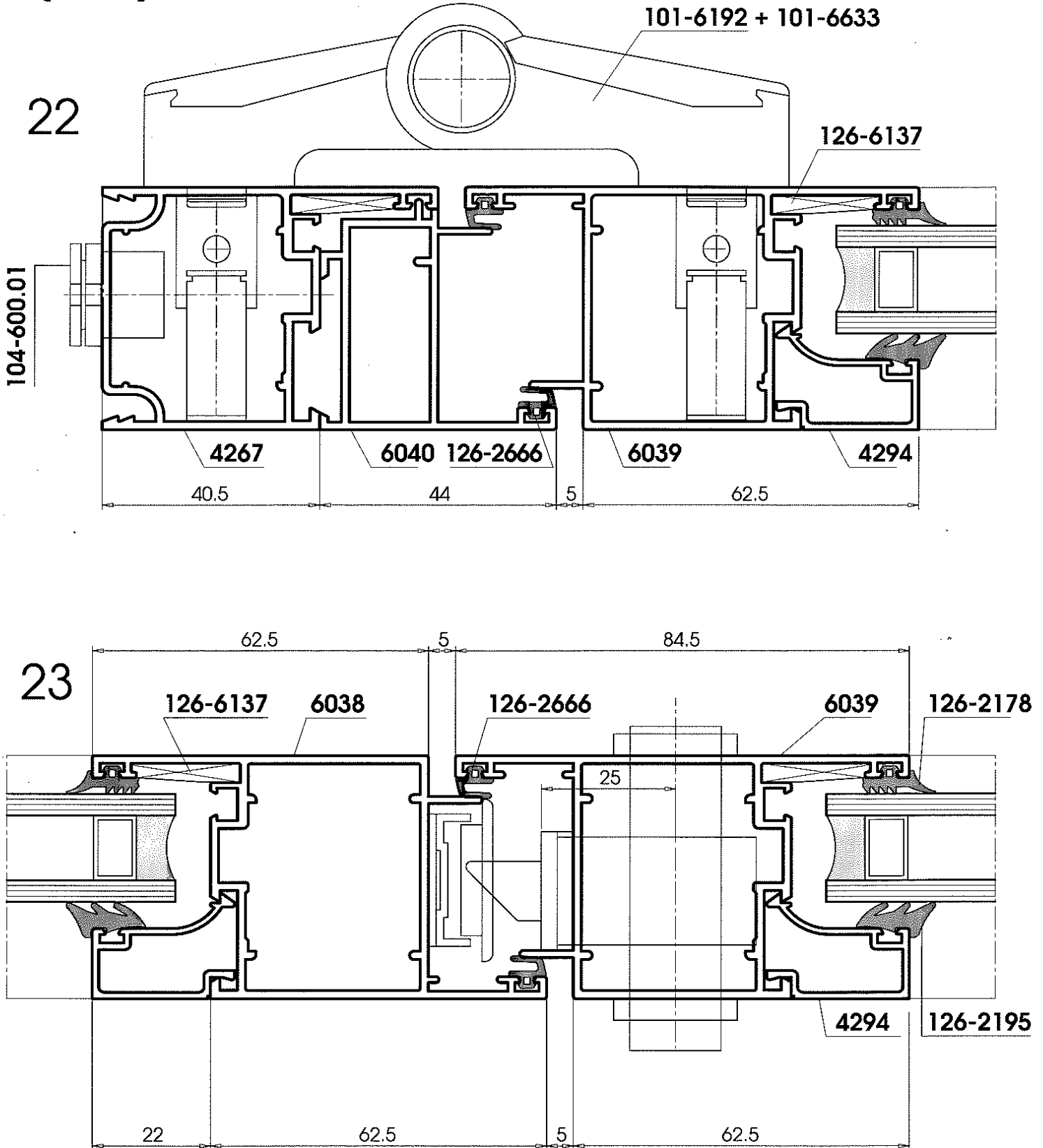
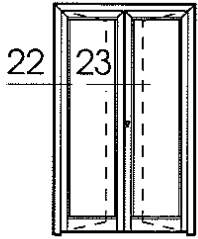

PERSIANA AD UNA ANTA
ONE WING SHUTTER WINDOW

60
SETTEMBRE '96

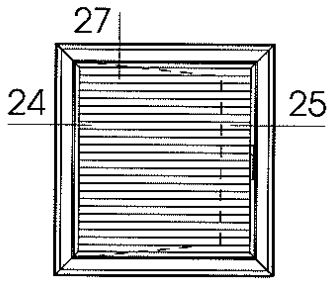

24

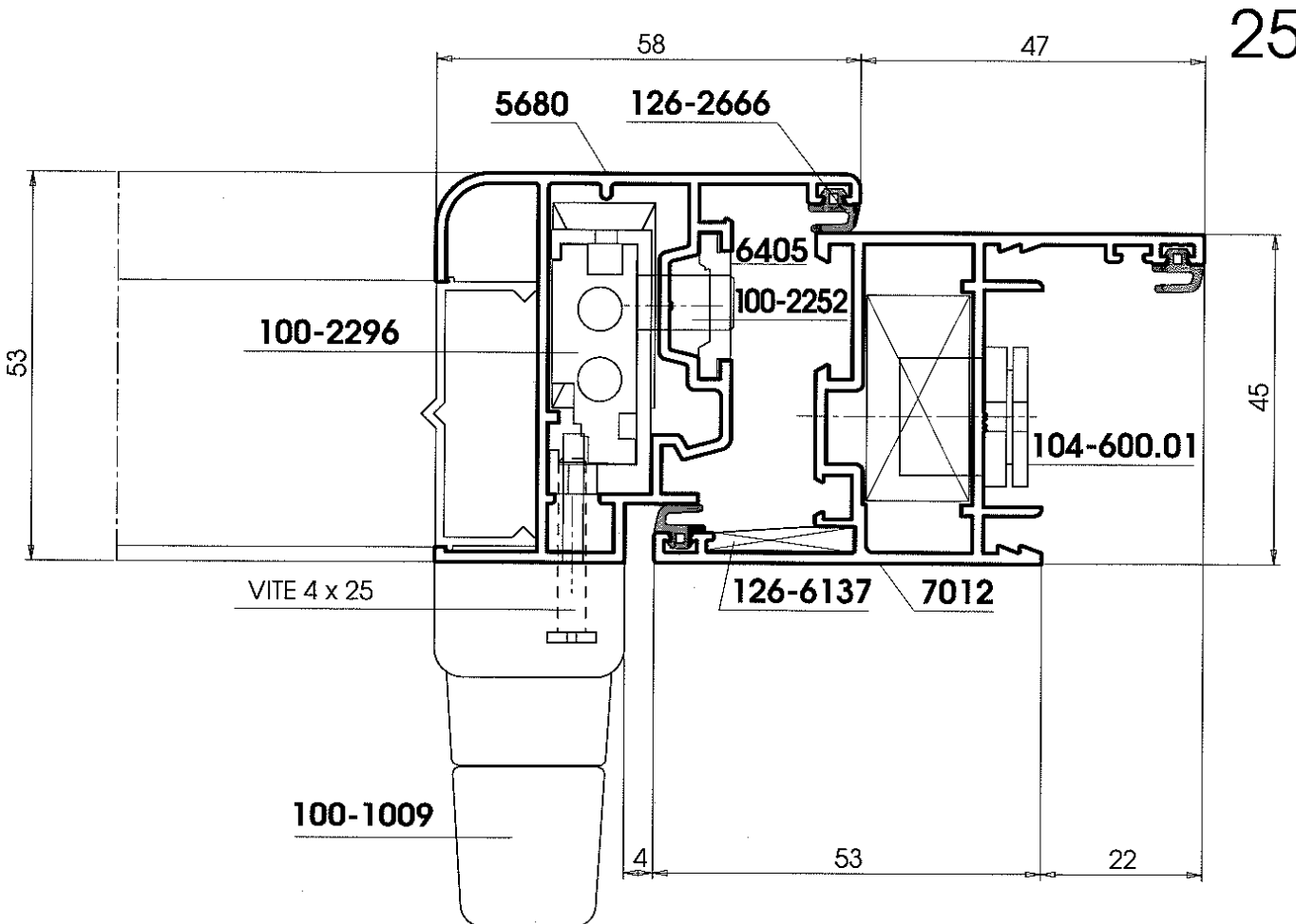
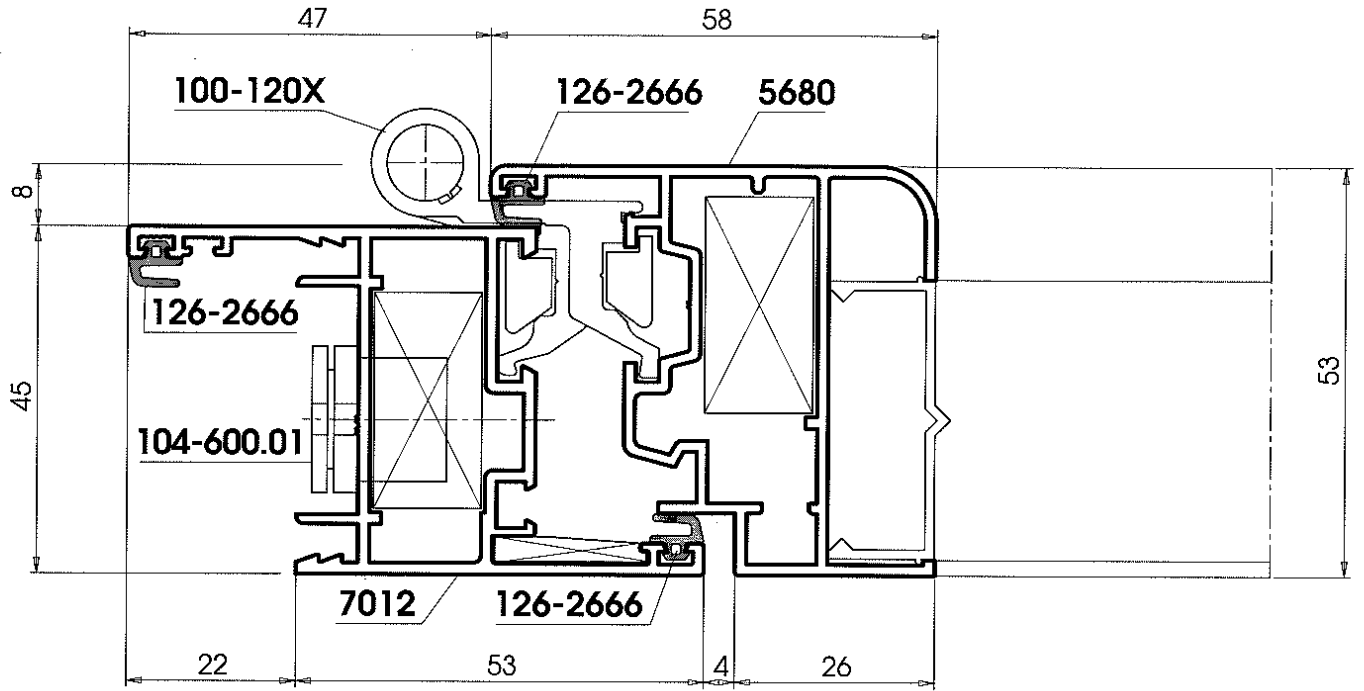

25

PERSIANA A DUE ANTE
TWO WINGS SHUTTER WINDOW

61

SETTEMBRE '96

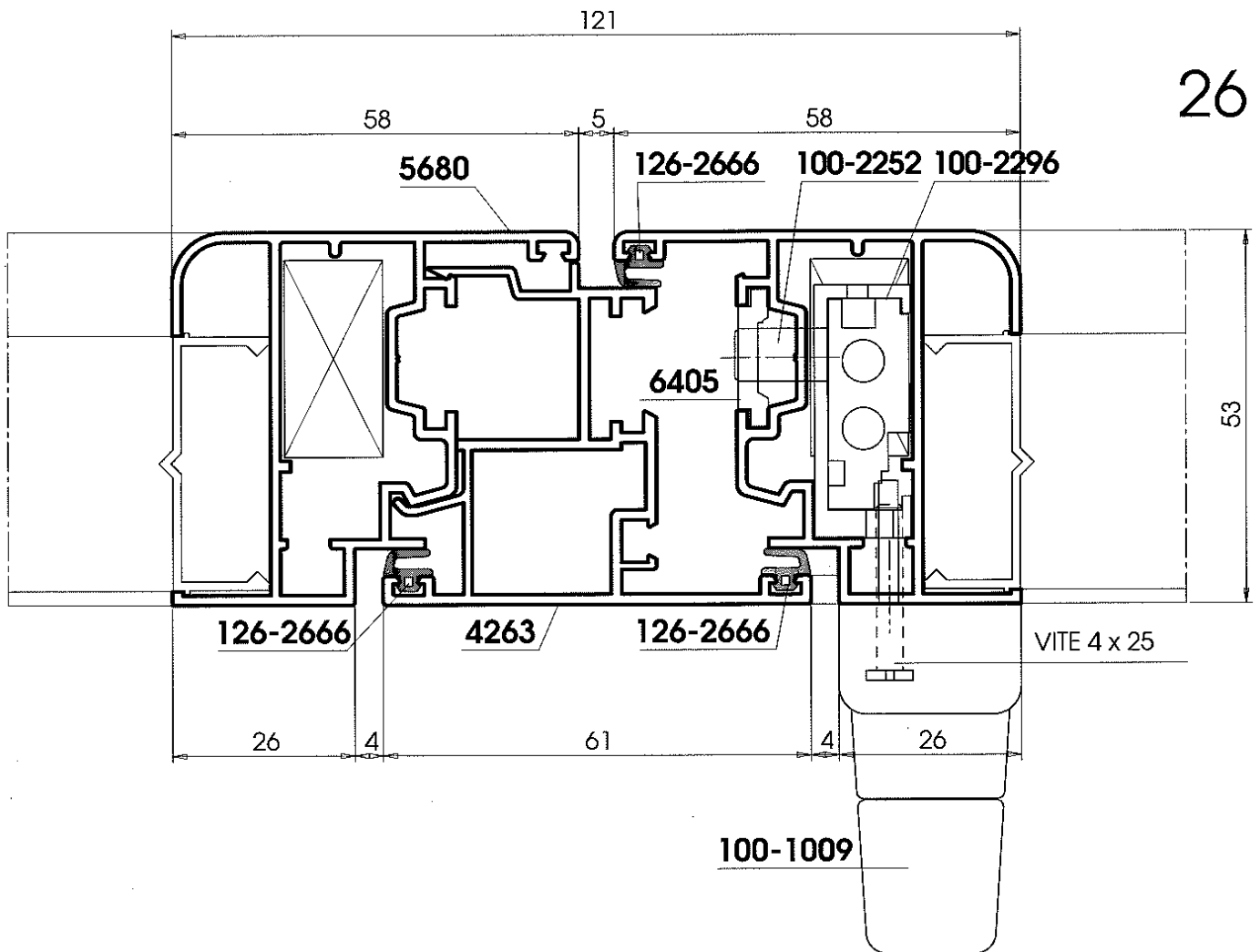
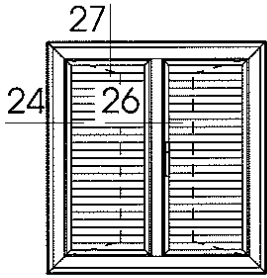

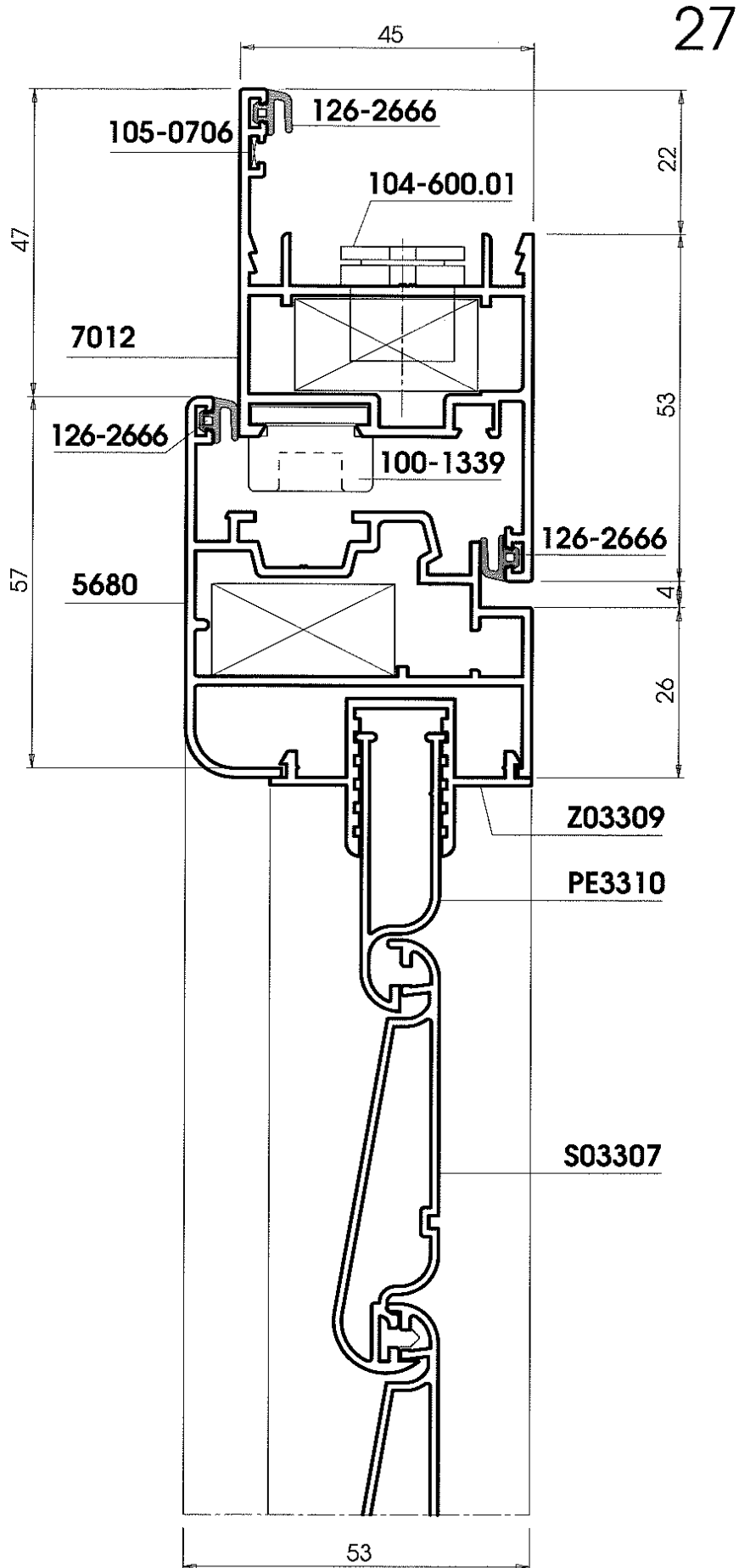
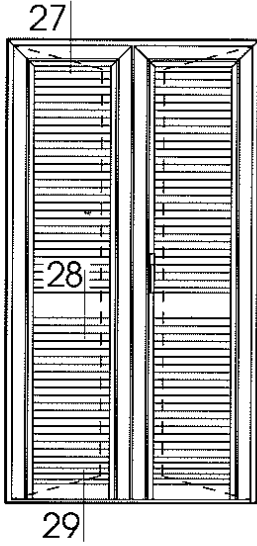

28

29

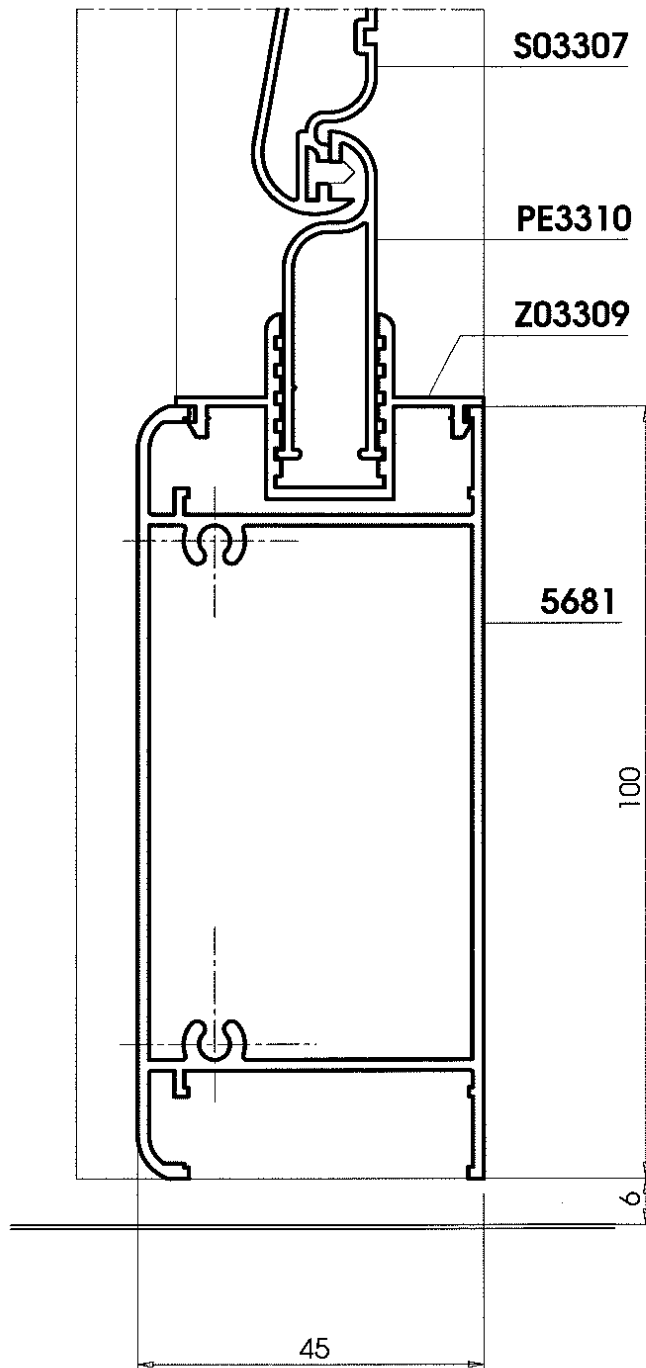
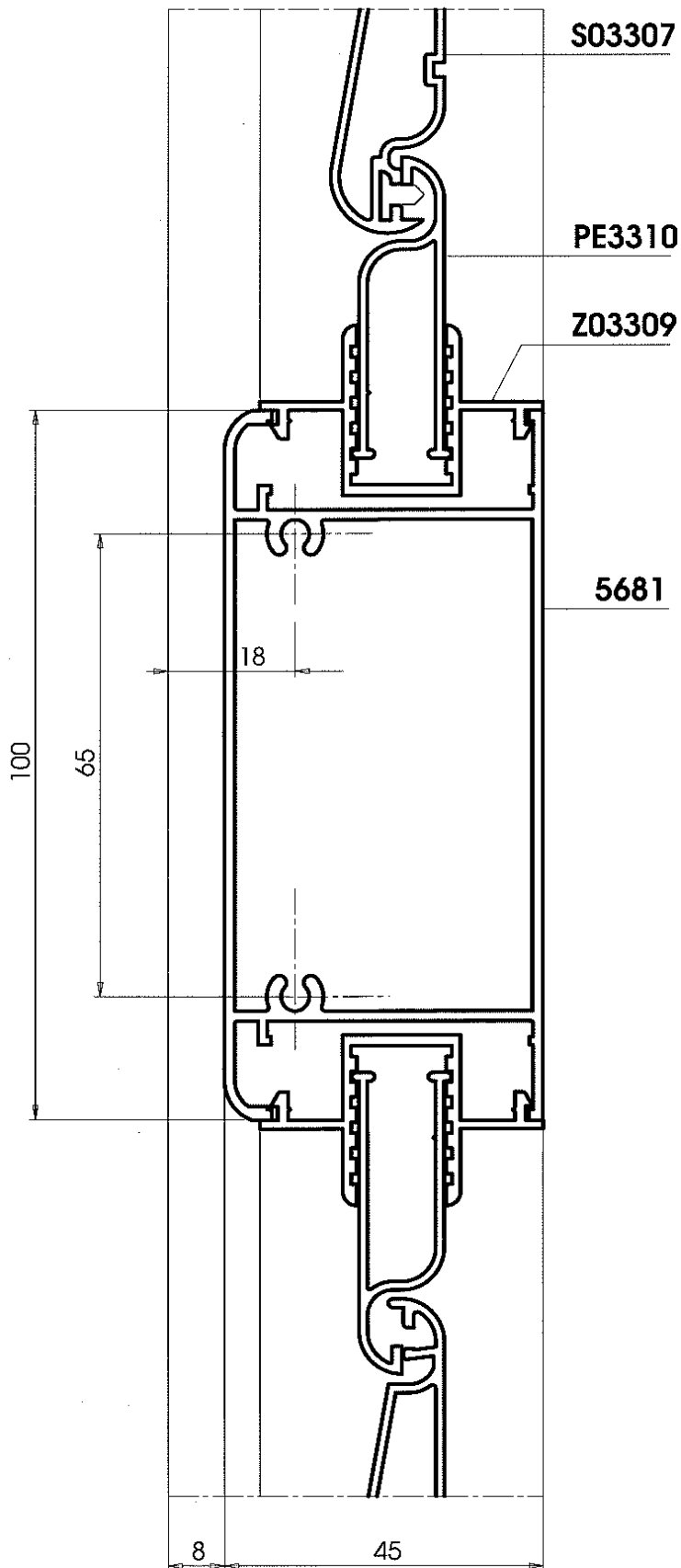

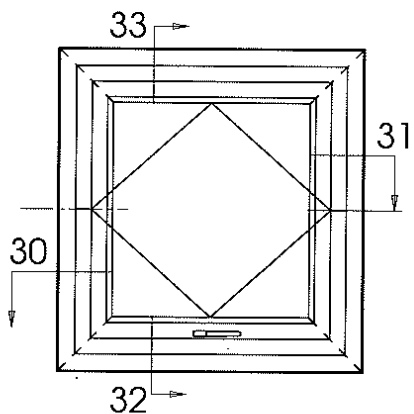

30

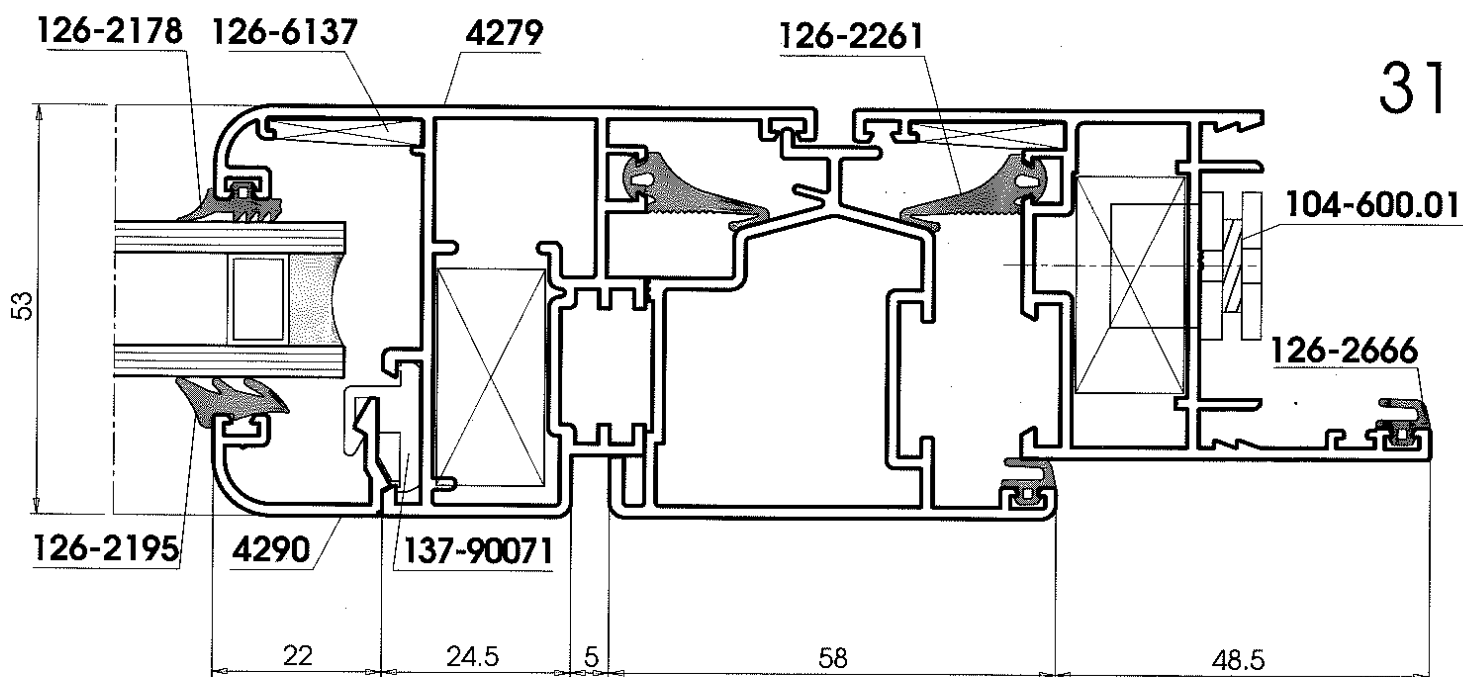
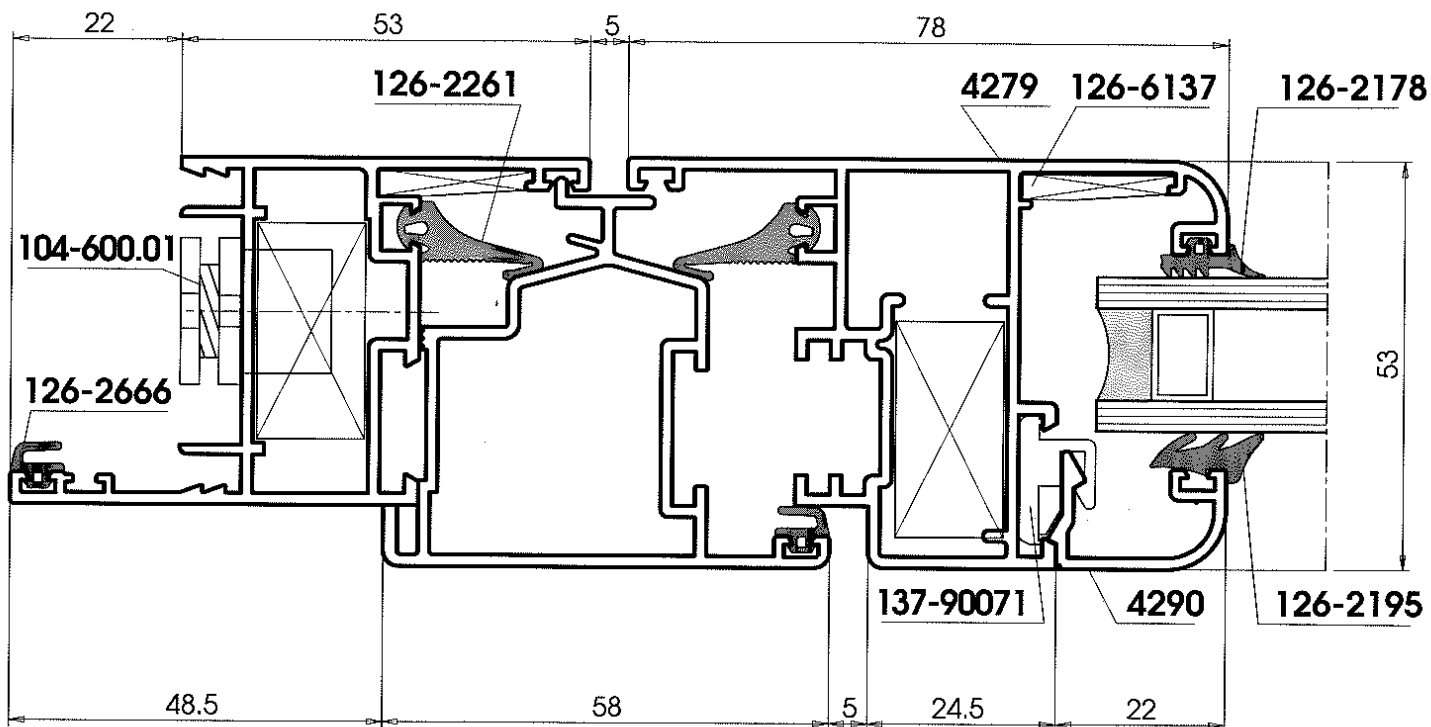

31

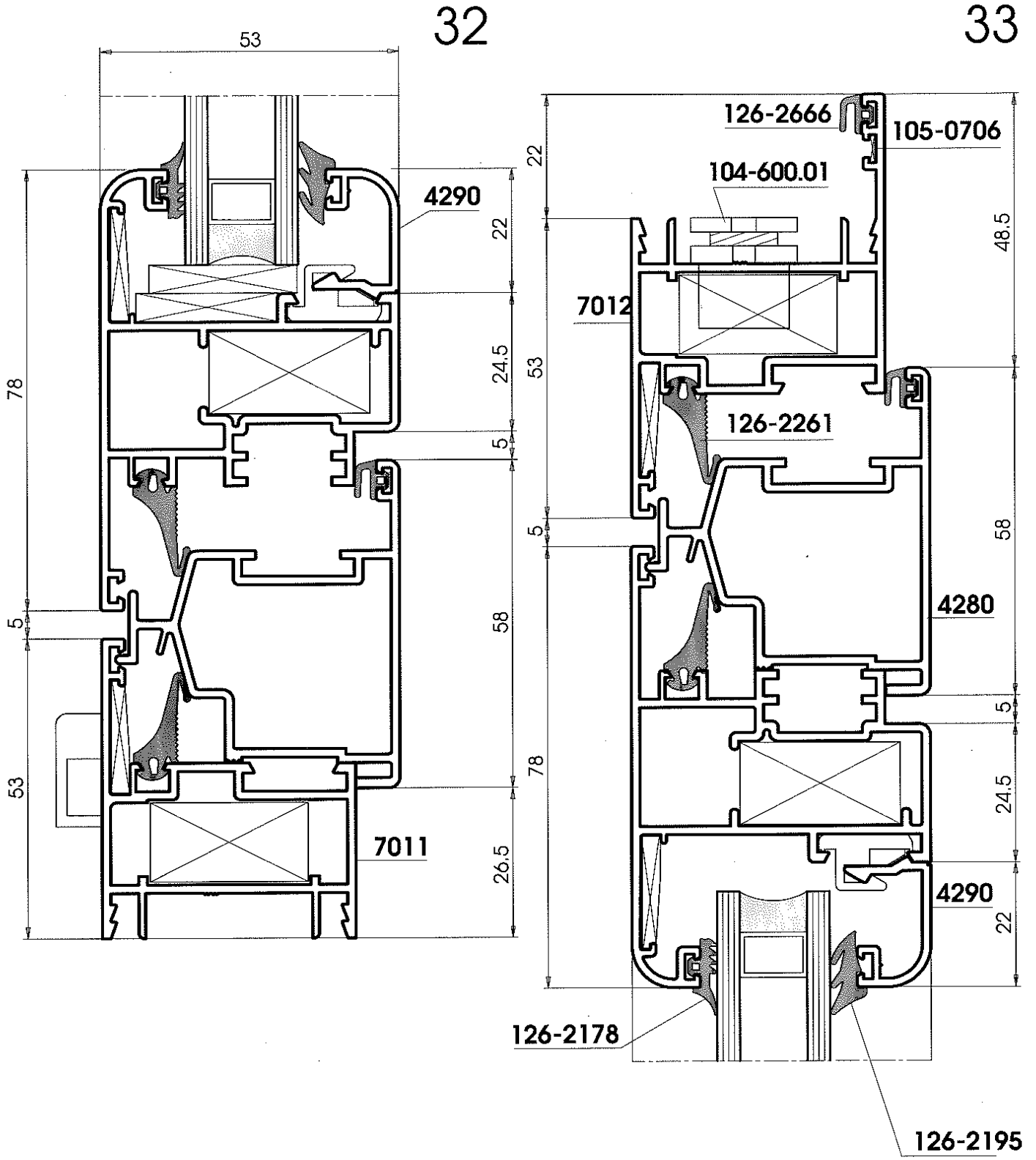

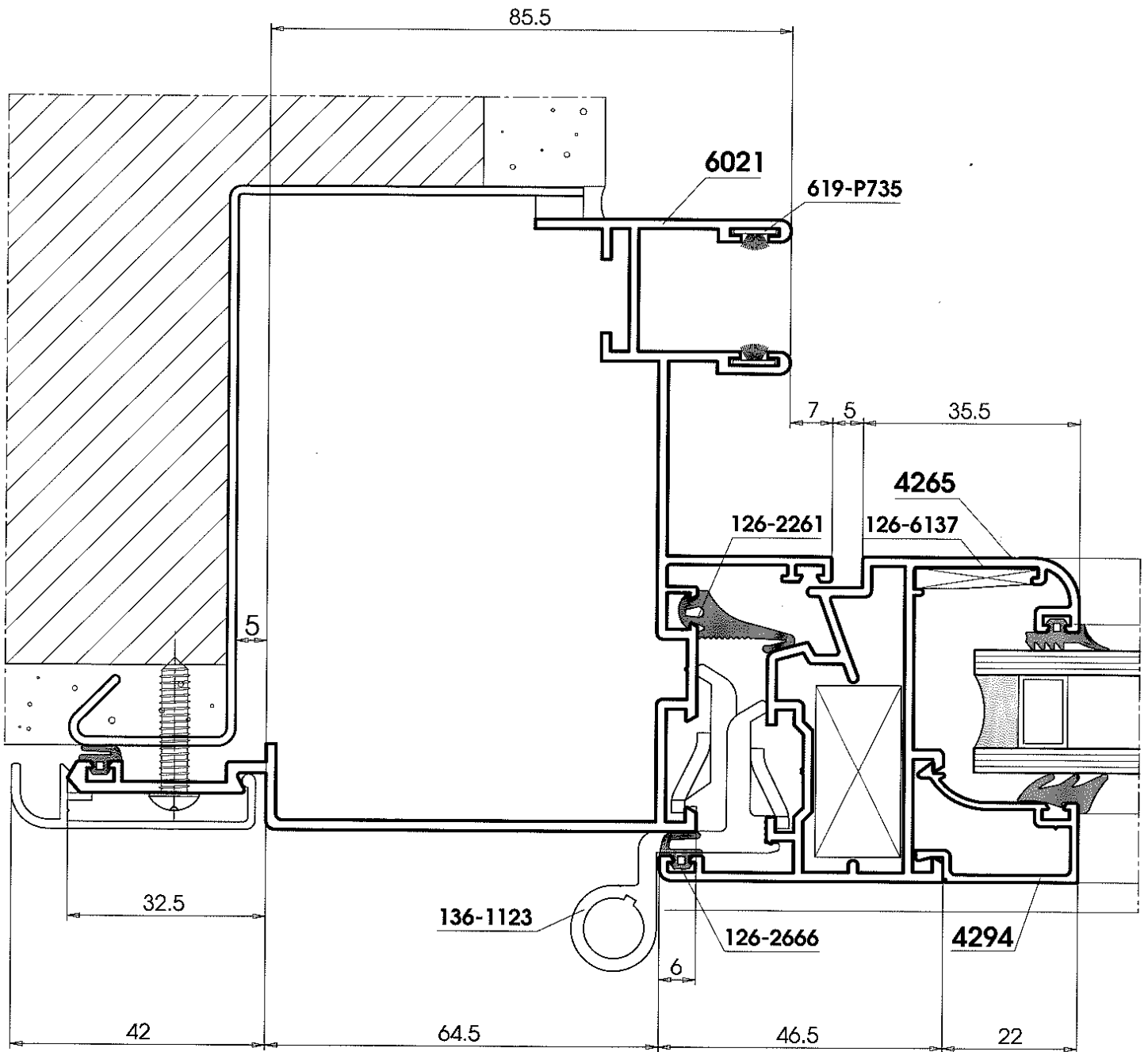
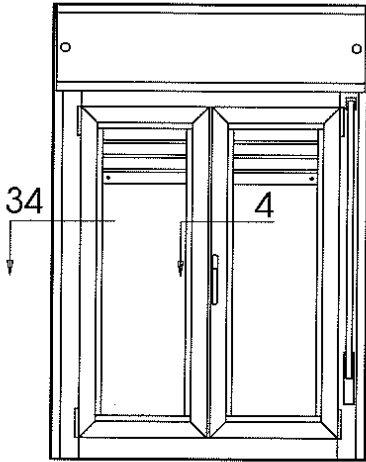

34

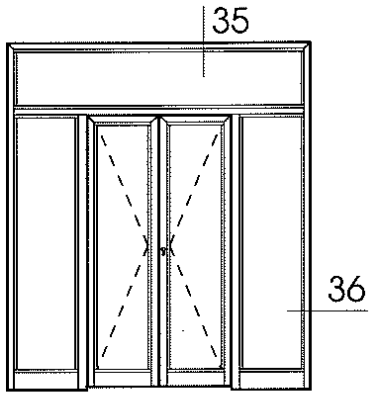

35

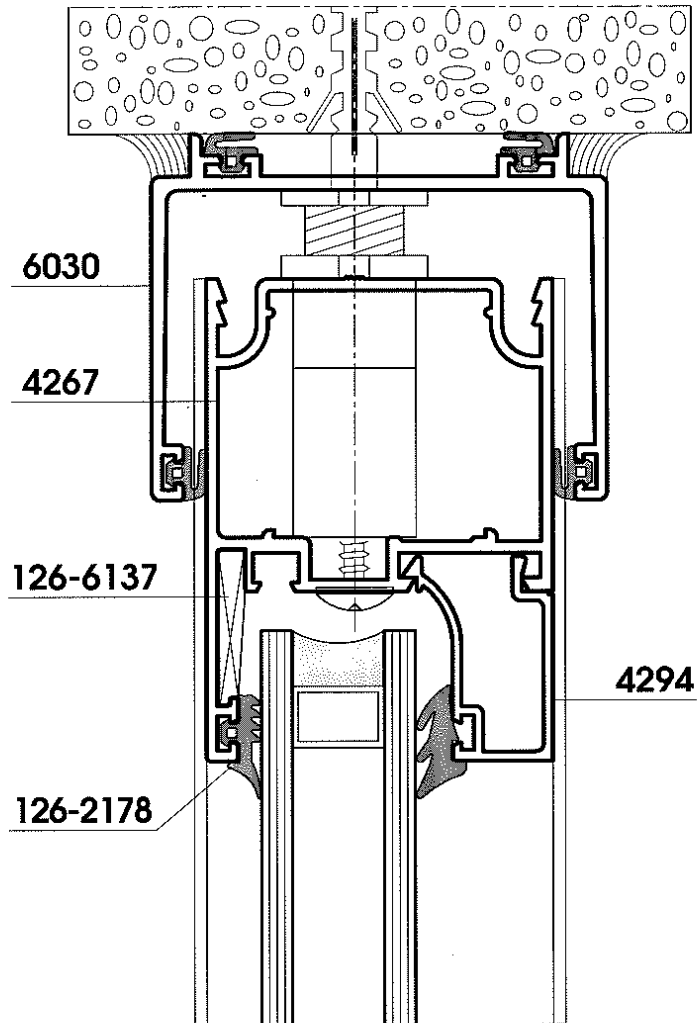

36

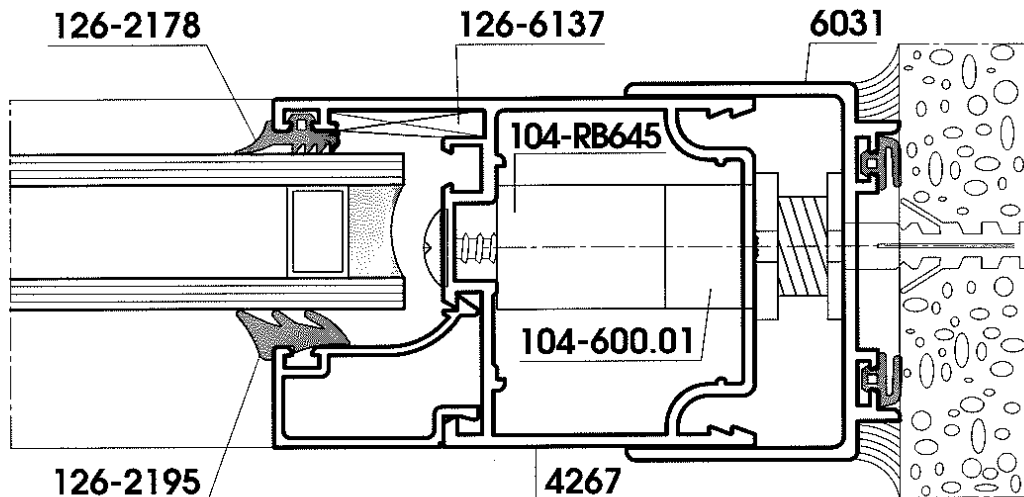

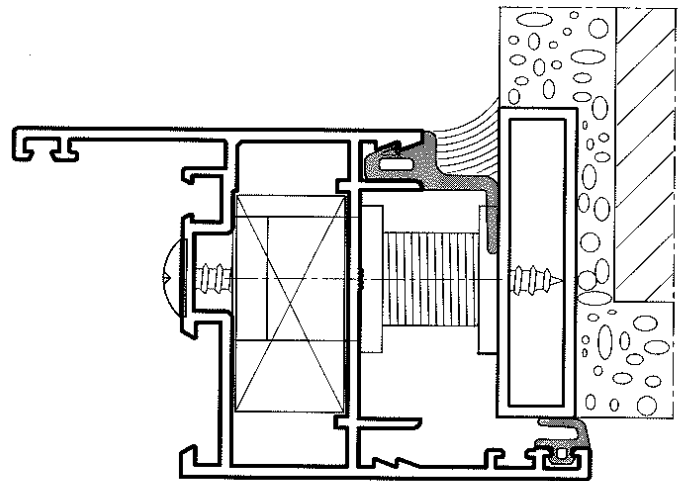
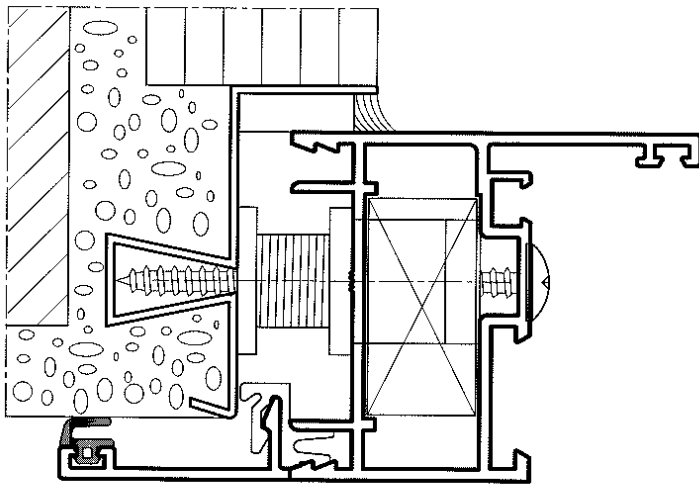
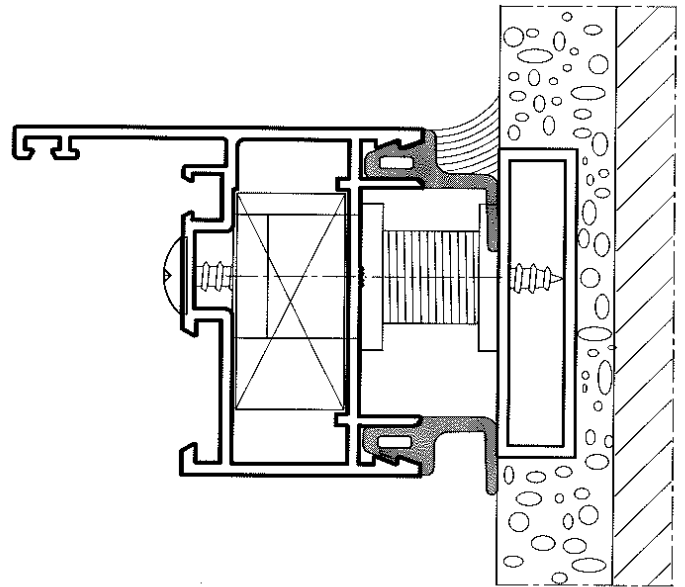
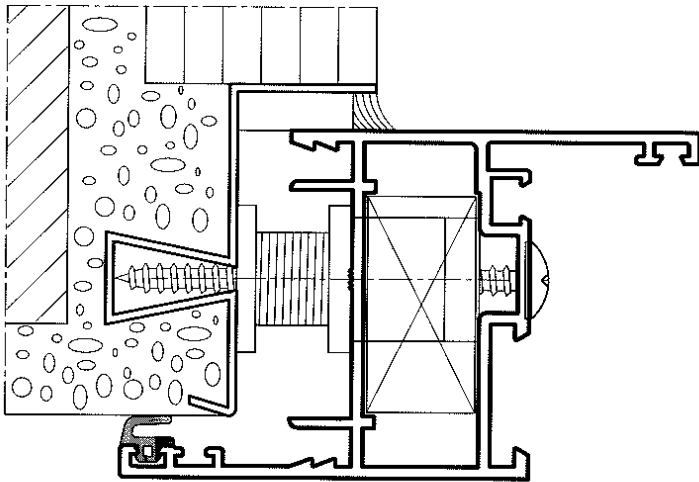
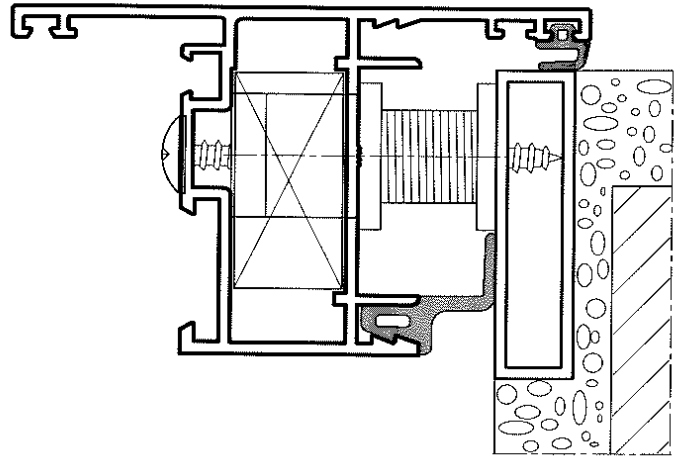
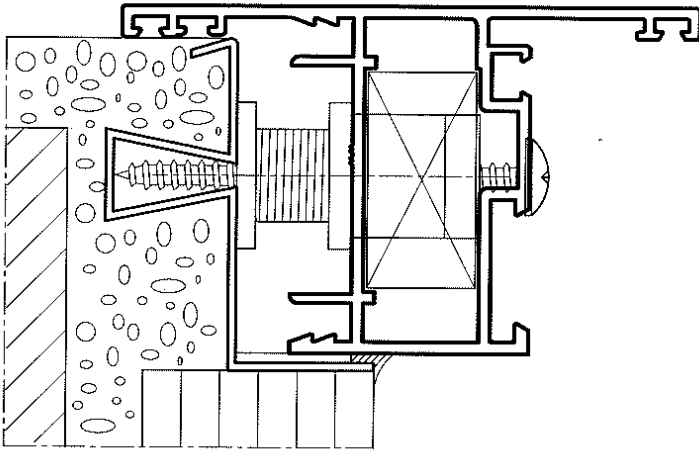

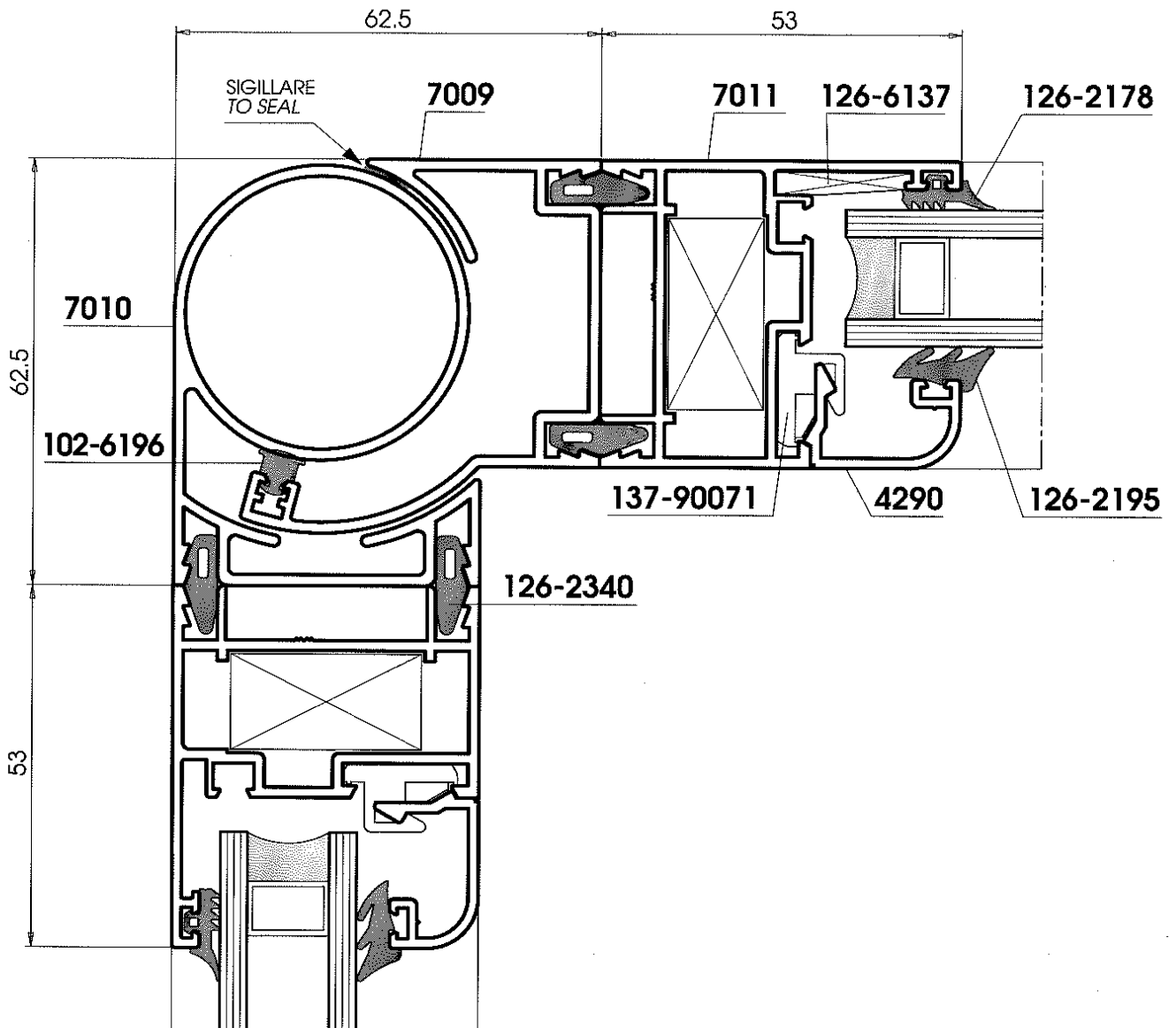

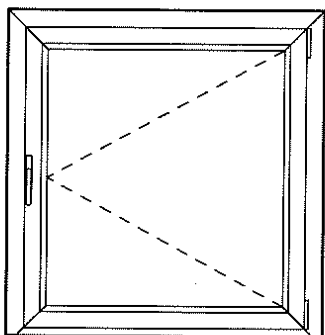







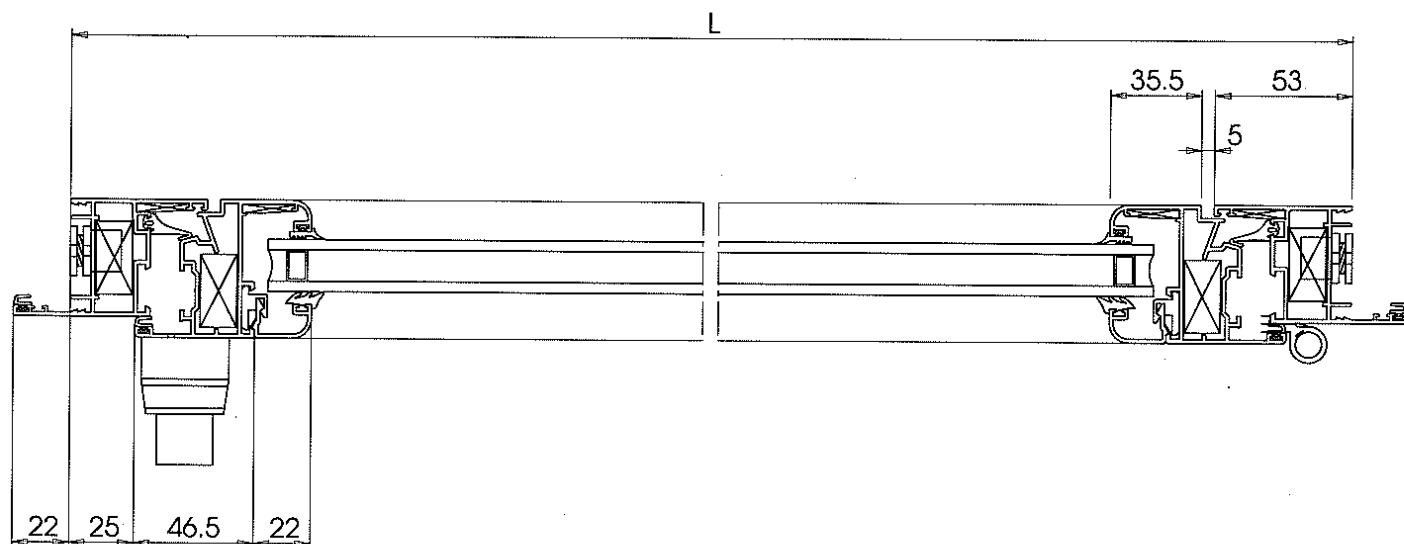
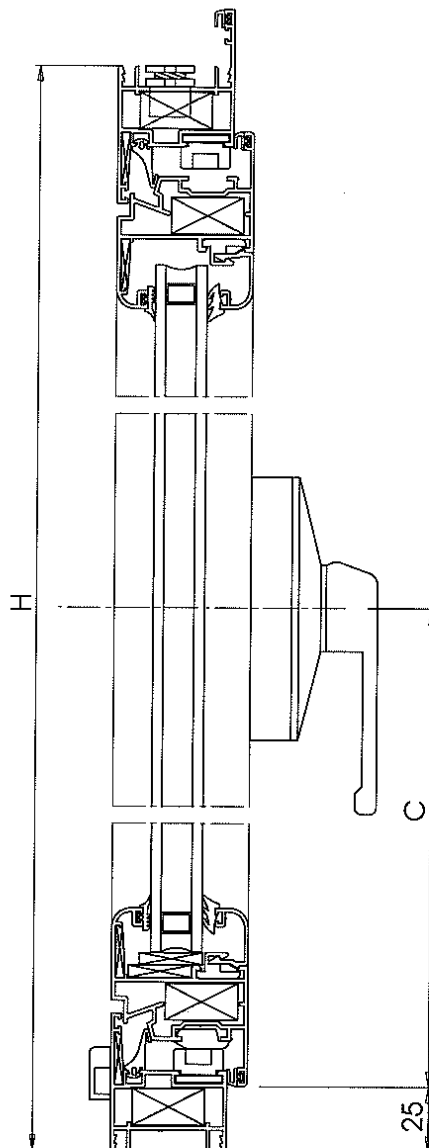

Note - Notes:

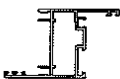
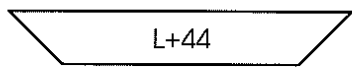
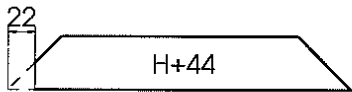
Spessore vetro considerato mm 20
For glass with 20 mm thickness

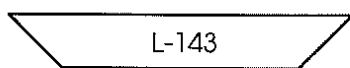
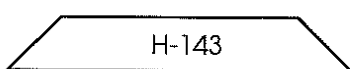
Gioco perimetrale tra profilo
e vetro mm 8 minimo
Space between glass and profile 8 mm minimum

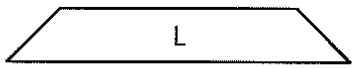
Vetri N° 1 pezzo per anta
Glasses N°1 piece for wing
(L-159) (H-159)

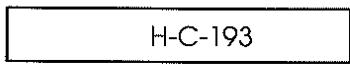
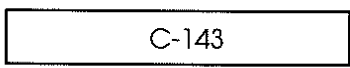

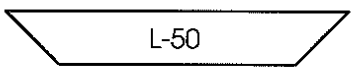
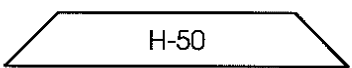
Profilo Profile	N° Pezzi Pcs	Schema di taglio Preparation	Profilo Profile	N° Pezzi Pcs	Schema di taglio Preparation
 7012	1 2	 	 4290	2 2	 
 7011	1		 6405	1 1	 
 4265	2 2	 			

Accessori Accessories			Accessori Accessories			Guarnizioni Gaskets	
Art. Item	Descrizione Description	N°. pezzi Pcs	Art. Item	Descrizione Description	N°. pezzi Pcs	Art. Item	N°. pezzi Pcs
104-600.01	Espansore Adjustable block	7	100-2114	Terminale aste Rod terminal	2	126-2666	3L+4H
* 105-0409	Squadretta a scatto Corner joint	8	100-2328	Drenaggio acqua Water drainage	2	126-2178	2L+2H
126-6137	Squad. allin.to telaio-anta Corner joint frame-wing	8	137-90071	Clip per fermavetri arrotondati Clips for rounded glass beading	12	126-2195	2L+2H
105-0706	Squadretta inox telaio Corner joint frame	2				126-2261	2L+2H
100-0120X	Cerniera "FLASH" Hinge	2				126-4147	4
100-1000	Cremonese "EURO" "EURO" cremonese bolt	1					
100-2387	Blocchetti collegamento Connections blocks	2					
100-1314	Incontro Rest plate	3					
100-2336	Sostegno anta Wing support	1					
			* Var. squadrette a cianfrinare o spinare Version corner joints locked by pin or chamfered				

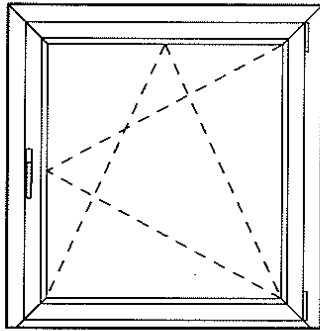







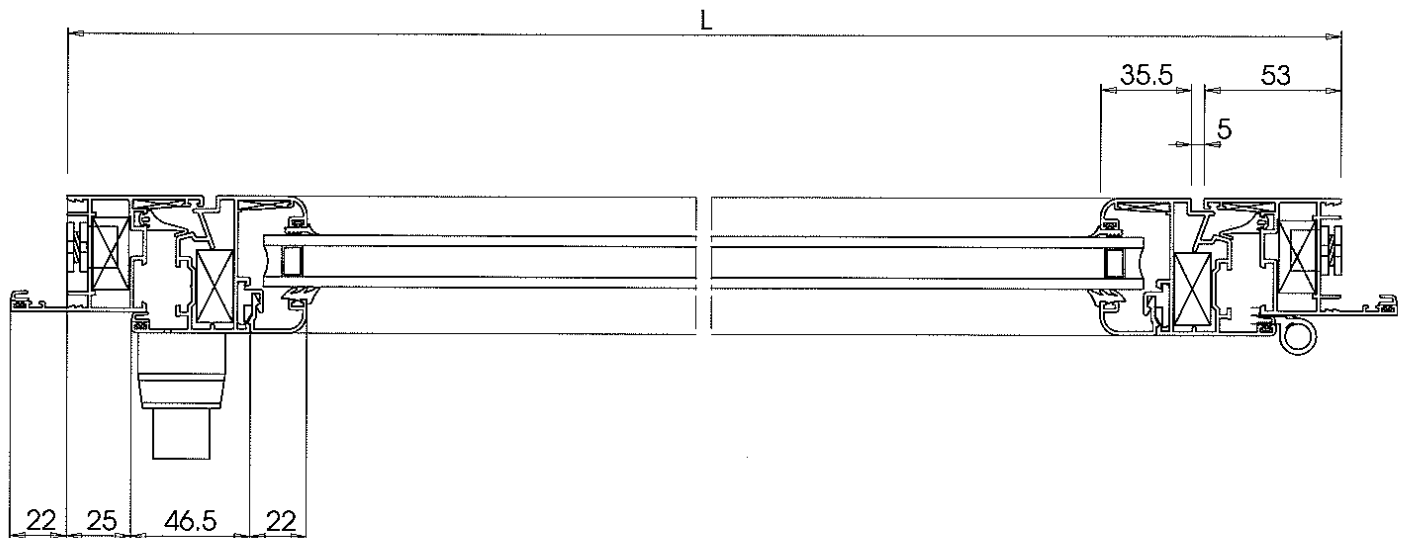
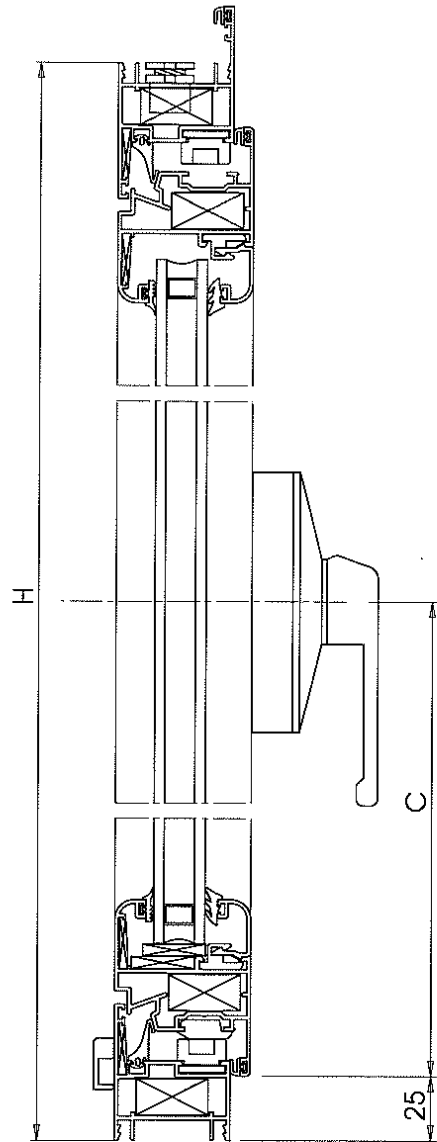

Note - Notes:

Spessore vetro considerato mm 20
 For glass with 20 mm thickness

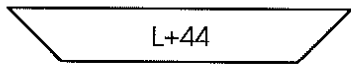
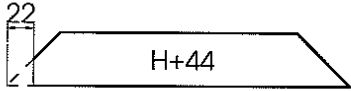
Gioco perimetrale tra profilo
 e vetro mm 8 minimo
 Space between glass and profile 8 mm minimum

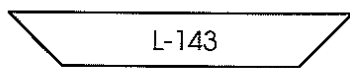
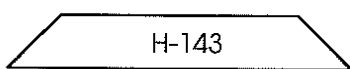
Vetri N° 1 pezzo per anta
 Glasses N°1 piece for wing
 (L-159) (H-159)

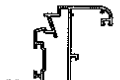
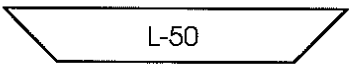
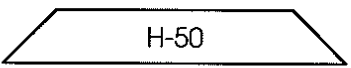

Profilo Profile	N° Pezzi Pcs	Schema di taglio Preparation	Profilo Profile	N° Pezzi Pcs	Schema di taglio Preparation
 7012	1 2	 	 4290	2 2	 
 7011	1		 6405	Vedi istruzioni nel kit See instructions on the kit	
 4265	2 2	 			

Accessori Accessories			Accessori Accessories			Guarnizioni Gaskets	
Art. Item	Descrizione Description	N°. pezzi Pcs	Art. Item	Descrizione Description	N°. pezzi Pcs	Art. Item	N°. pezzi Pcs
104-600.01	Espansore Adjustable block	7	100-2328	Drenaggio acqua Water drainage	2	126-2666	3L+4H
* 105-0409	Squadretta a scatto Corner joint	8	137-90071	Clip per fermavetri arrotondati Clips for rounded glass beading	12	126-2178	2L+2H
126-6137	Squad. allin.to telaio-anta Corner joint frame-wing	8				126-2195	2L+2H
105-0706	Squadretta inox telaio Corner joint frame	2				126-2261	2L+2H
100-4501	Kit base anta/ribalta Kit for tilt-turn	1				126-4147	4
100-1090	Cremonese "EURO" "EURO" cremonese bolt	1					
100-4221	Braccio medio tipo 2 Widdle arm type 2	1					
100-4241	Chiusura suppl. vert. Additional vertical lock	1					
100-4251	Chiusura suppl. oriz. Additional horizontal lock	1					

* Var. squadrette a cianfrinare o spinare
Version corner joints locked by pin or chamfered

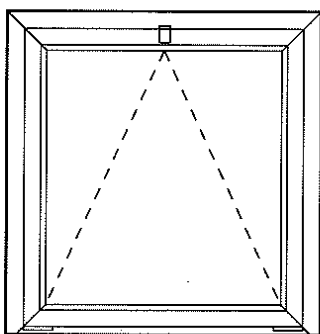





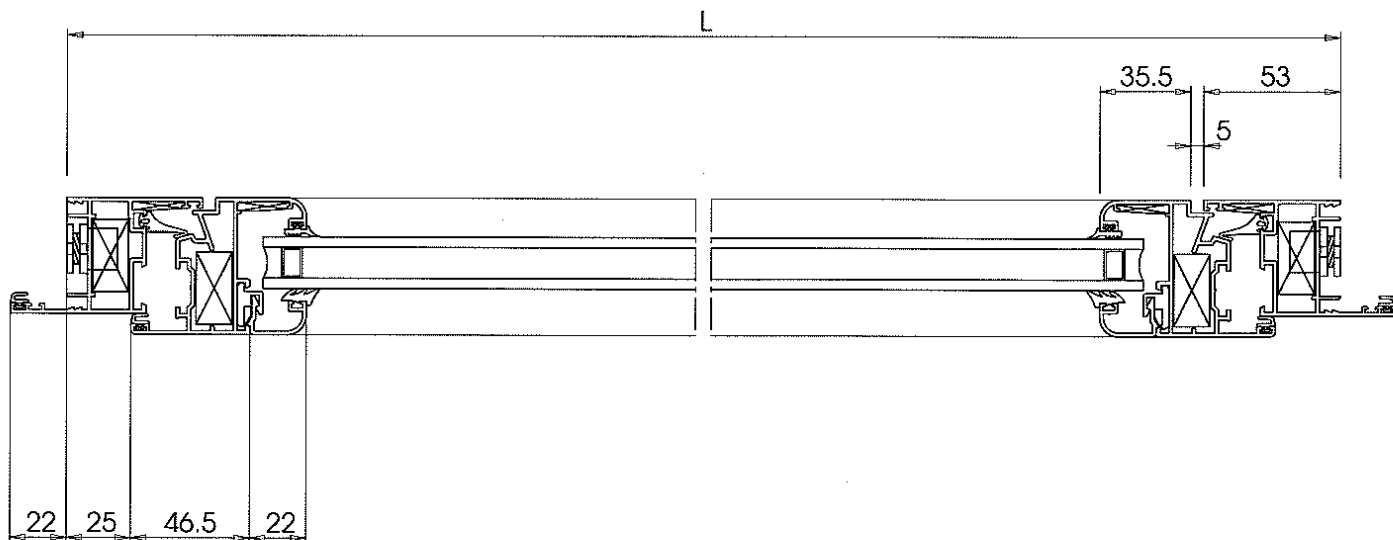
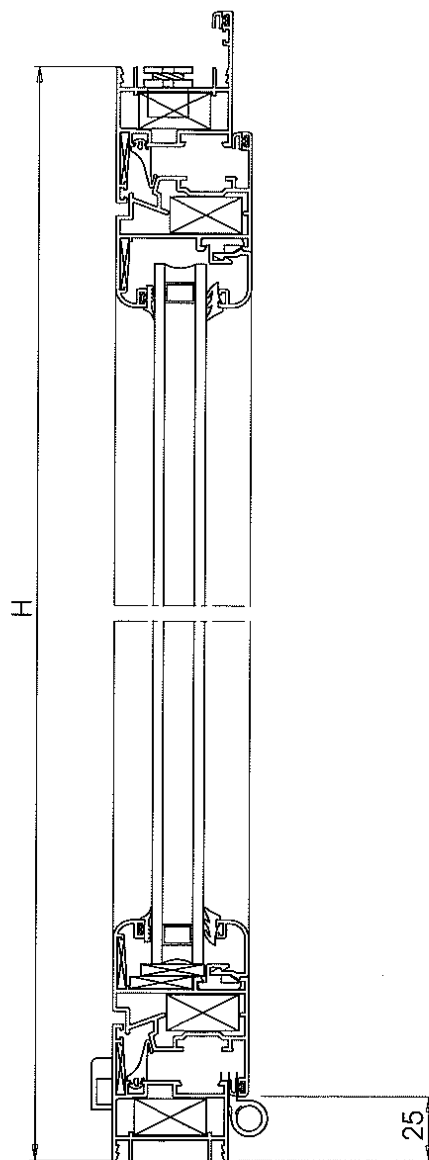

Note - Notes:

Spessore vetro considerato mm 20
For glass with 20 mm thickness

Gioco perimetrale tra profilo
e vetro mm 8 minimo
Space between glass and profile 8 mm minimum

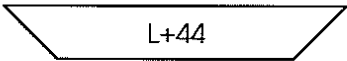
Vetri N° 1 pezzo per anta
Glasses N°1 piece for wing
(L-159) (H-159)

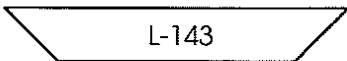
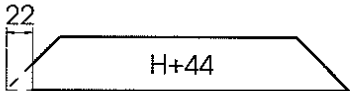
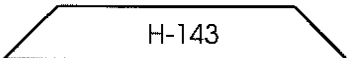

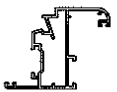
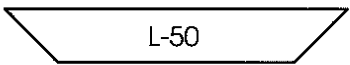
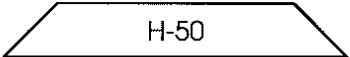
Profilo Profile	N° Pezzi Pcs	Schema di taglio Preparation	Profilo Profile	N° Pezzi Pcs	Schema di taglio Preparation
	1	 L+44		2	 L-143
7012	2	 H+44	4290	2	 H-143
	1	 L			
7011					
	2	 L-50			
4265	2	 H-50			

Accessori Accessories			Accessori Accessories			Guarnizioni Gaskets	
Art. Item	Descrizione Description	N° pezzi Pcs	Art. Item	Descrizione Description	N° pezzi Pcs	Art. Item	N° pezzi Pcs
104-600.01	Espansore Adjustable block	7	137-90071	Clij per femavevri arrotondati Clips for rounded glass beading	12	126-2666	3L+4H
* 105-0409	Squadretta a scatto Corner joint	8				126-2178	2L+2H
126-6137	Squad. allin.to telaio-anta Corner joint frame-wing	8				126-2195	2L+2H
105-0706	Squadretta inox telaio Corner joint inox frame	2				126-2261	2L+2H
100-120X	Cerniera "FLASH" "FLASH" hinge	2				126-4147	4
100-2040	Braccio lungo "RALLENTY" "RALLENTY" Long arm	1					
100-1701	Cricchetto "GRISBI" Spring	1					
100-2328	Drenaggio acqua Water drainage	2					
			* Var. squadrette a cianfrinare o spinare Version corner joints locked by pin or chamfered				

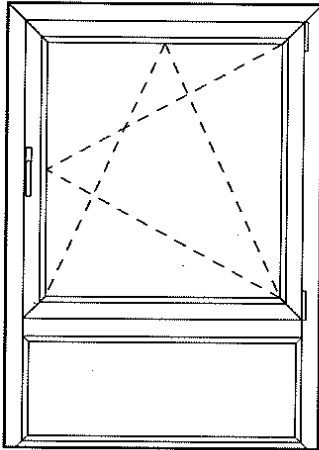

Note - Notes:





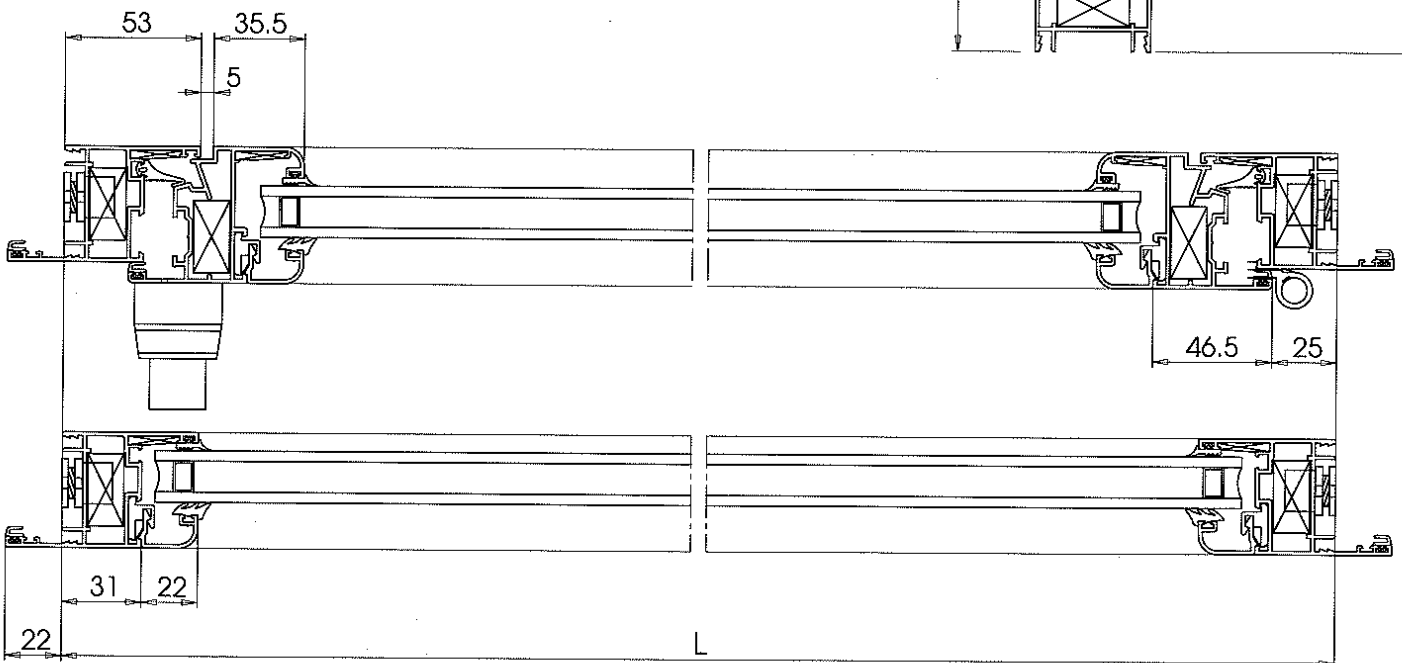
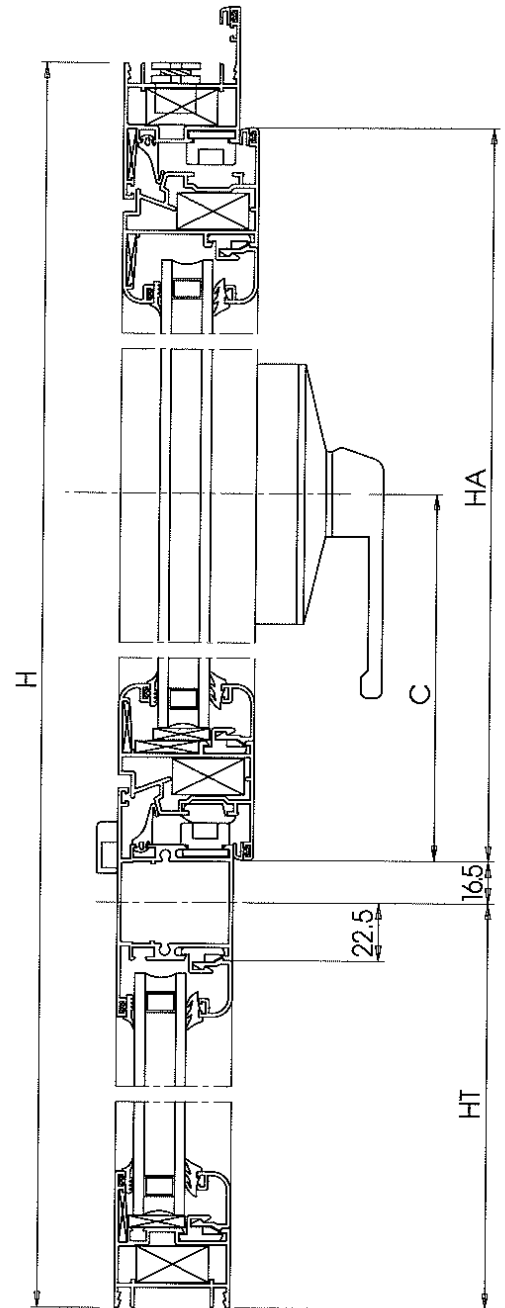

Spessore vetro considerato mm 20
 For glass with 20 mm thickness

Gioco perimetrale tra profilo
 e vetro mm 8 minimo
 Space between glass and profile 8 mm minimum

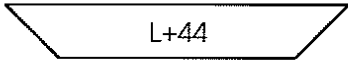
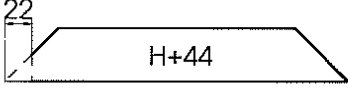
Vetri N° 1 pezzo per anta
 Glasses N°1 piece for wing
 (L-159) (H-HT-150.5)

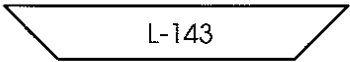
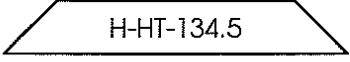
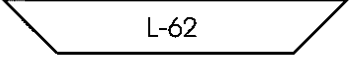
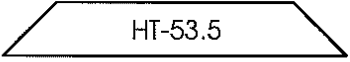
Vetri N° 1 pezzo per parti fisse
 Glasses N°1 piece for fixed frame
 (L-78) (HT-69.5)

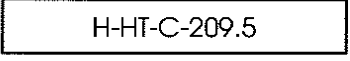
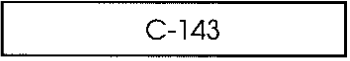
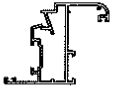
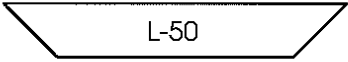
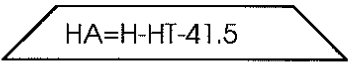
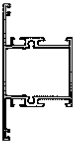
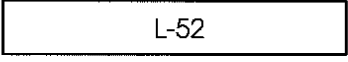

Profilo Profile	N° Pezzi Pcs	Schema di taglio Preparation	Profilo Profile	N° Pezzi Pcs	Schema di taglio Preparation
 7012	1 2	 	 4290	2 2 2	   
 7011	1		 6405	2 2	 
 4265	2 2	 	 4285	1	

Accessori Accessories			Accessori Accessories			Guarnizioni Gaskets	
Art. Item	Descrizione Description	N°. pezzi Pcs	Art. Item	Descrizione Description	N°. pezzi Pcs	Art. Item	N°. pezzi Pcs
104-600.01	Espansore Adjustable block	7	100-2328	Drenaggio acqua Water drainage	4	126-2666	3L+4H
* 105-0409	Squadretta a scatto Corner joint	8	137-90071	Clip per fermavetri arrotondati Clips for rounded glass beading	20	126-2178	4L+2H
126-6137	Squad. allin.to telaio-anta Corner joint frame-wing	8				126-2195	4L+2H
105-0706	Squadretta inox telaio Corner joint frame	2				126-2261	2L+2H
100-4501	Kit base anta/ribalta Kit for tilt-turn	1				126-4147	4
100-1090	Cremonese "EURO" "EURO" cremonese bolt	1					
100-4221	Braccio medio tipo 2 Middle arm type 2	1					
100-4241	Chiusura suppl. vert. Additional vertical lock	1					
100-4251	Chiusura suppl. orizz. Additional horizontal lock	1					
			* Var. squadrette a cianfrinare o spinare Version corner joints locked by pin or chamfered				

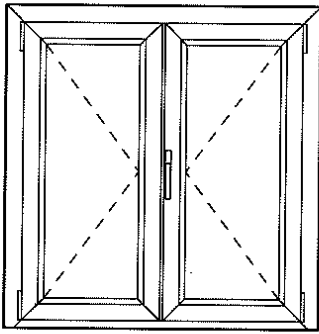









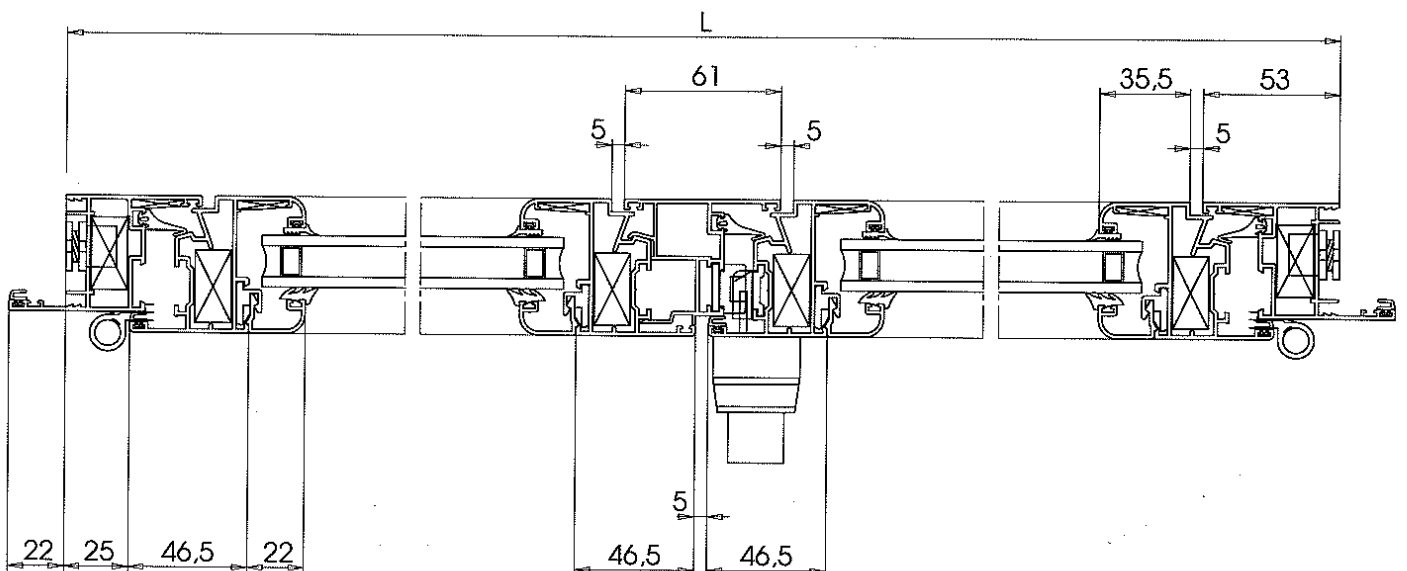
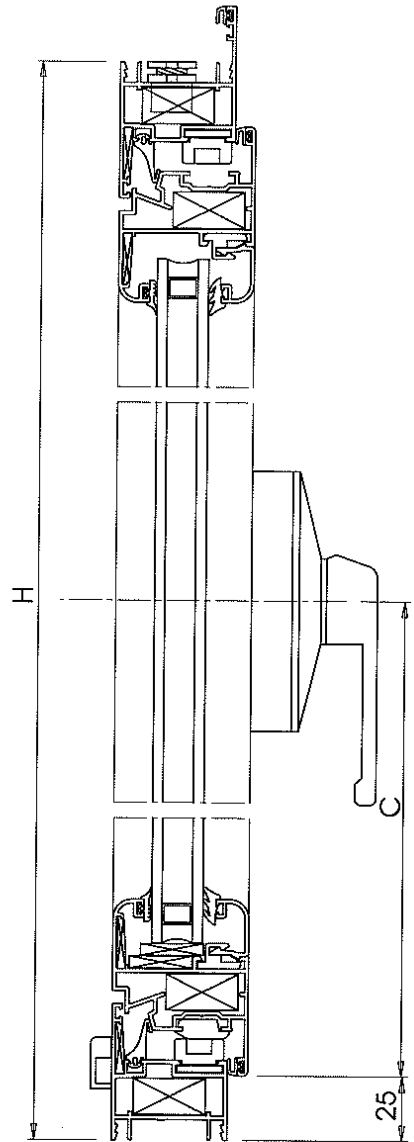

Note - Notes:

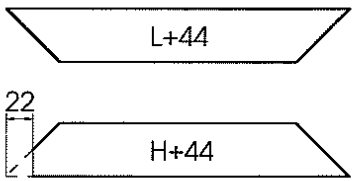
Spessore vetro considerato mm 20
 For glass with 20 mm thickness

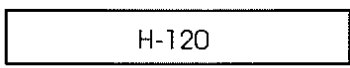
Gioco perimetrale tra profilo
 e vetro mm 8 minimo
 Space between glass and profile 8 mm minimum

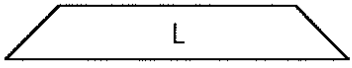
Vetri N° 2 pezzi
 Glasses N°2 pieces
 ((L - 273)/2) (H-159)

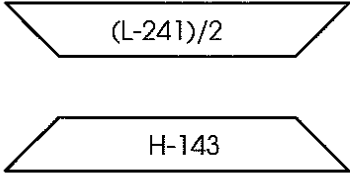
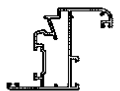
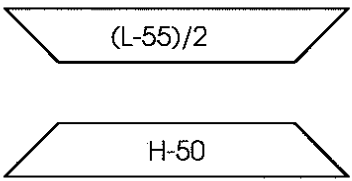

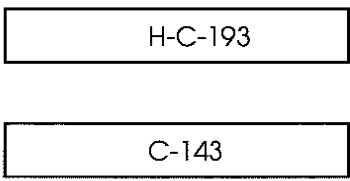
Profilo Profile	N° Pezzi Pcs	Schema di taglio Preparation	Profilo Profile	N° Pezzi Pcs	Schema di taglio Preparation
 7012	1 2		 4263	1	
 7011	1		 4290	4 4	
 4265	4 4		 6405	1 1	

Accessori Accessories			Accessori Accessories			Guarnizioni Gaskets	
Art. Item	Descrizione Description	N° pezzi Pcs	Art. Item	Descrizione Description	N° pezzi Pcs	Art. Item	N° pezzi Pcs
104-600.01	Espansore Adjustable block	8	100-2336	Sostegno anta Wing support	2	126-2666	3L+5H
* 105-0409	Squadretta a scatto Corner joint	12	100-1339	Incontro doppio Double rest plate	2	126-2178	2L+4H
126-6137	Squad. allin.to telaio-anta Corner joint frame-wing	12	100-2114	Terminale aste Rod terminal	2	126-2195	2L+4H
105-0706	Squadretta inox telaio Corner joint frame	2	100-2111	Catenaccio "GIAP" "GIAP" latch	2	126-2261	2L+3H
137-93497	Tappi riporto centrale Seal plug on central prof.	1	100-2328	Drenaggio acqua Water drainage	3	126-4147	4
100-0120X	Cerniera "FLASH" Hinge	4	137-90071	Clip per fermavetri arrotondati Clips for rounded glass beading	20		
100-1000	Cremonese "EURO" "EURO" cremone bolt	1					
100-2387	Blocchetti collegamento Connections blocks	1					
100-1314	Incontro 3° chiusura Rest plate for 3rd stop	1					

* Var. squadrette a cianfrinare o spinare
Version corner joints locked by pin or chamfered

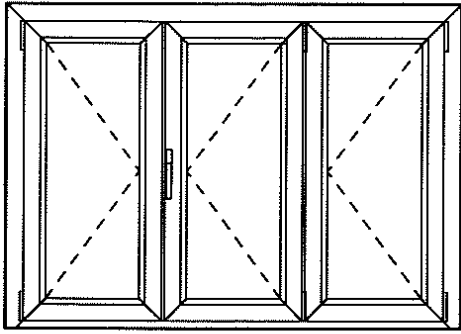









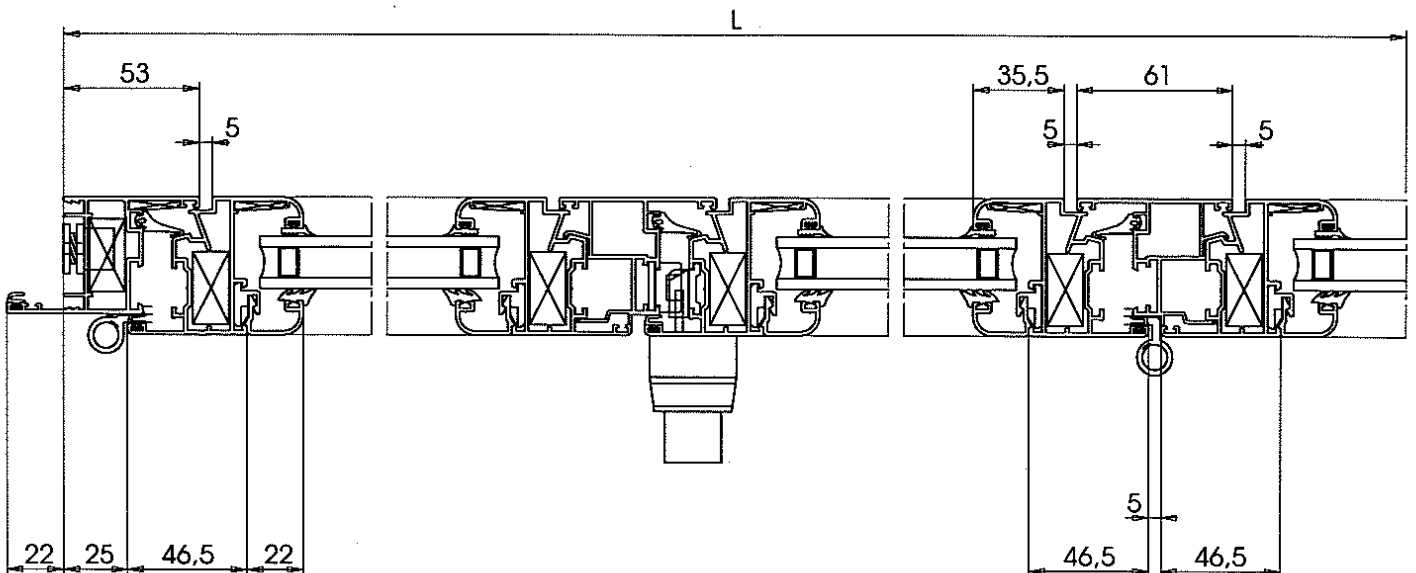
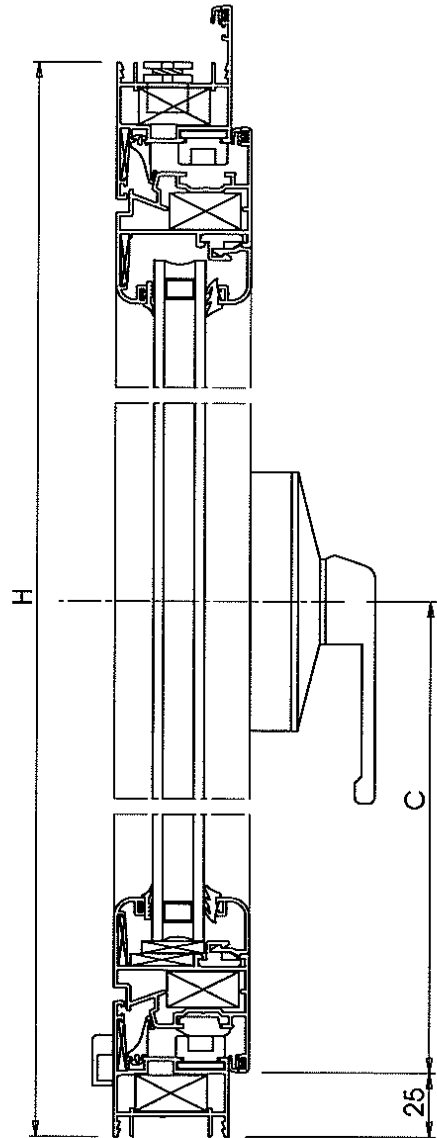

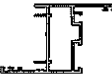
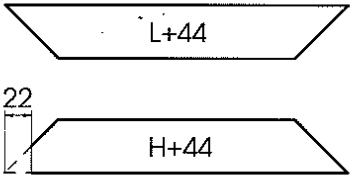
Note - Notes:

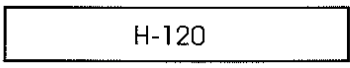
Spessore vetro considerato mm 20
 For glass with 20 mm thickness

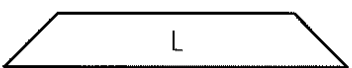
Gioco perimetrale tra profilo
 e vetro mm 8 minimo
 Space between glass and profile 8 mm minimum

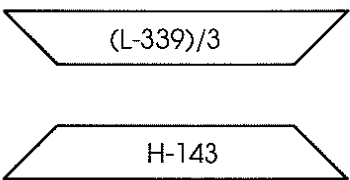
Vetri N° 1 pezzo per anta
 Glasses N°1 piece for wing
 [(L-387)/3] (H-159)

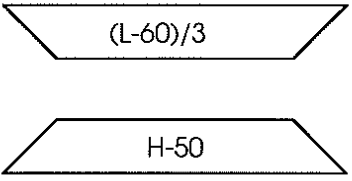

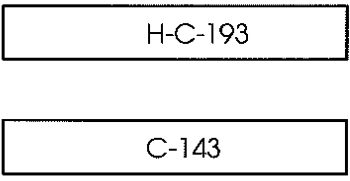
Profilo Profile	N° Pezzi Pcs	Schema di taglio Preparation	Profilo Profile	N° Pezzi Pcs	Schema di taglio Preparation
 7012	1 2		 4263	2	
 7011	1		 4290	6 6	
 4265	6 6		 6405	1 1	

Accessori

Accessories

Art. Item	Descrizione Description	N°. pezzi Pcs
104-600.01	Espansore Adjustable block	9
* 105-0409	Squadretta a scatto Corner joint	16
126-6137	Squad. allin.to telaio-anta Corner joint frame-wing	16
105-0706	Squadretta inox telaio Corner joint frame	2
137-93497	Tappi riporto centrale Seal plug on central prof.	2
100-0120X	Cerniera "FLASH" Hinge	4
100-0143X	Cerniera "FLASH" per 3° anta Hinge for third wing	2
100-1000	Cremonese "EURO" "EURO" cremonese bolt	1
100-2387	Blocchetti collegamento Connections blocks	1

Accessori

Accessories

Art. Item	Descrizione Description	N°. pezzi Pcs
100-1314	Incontro 3° chiusura Rest plate for 3rd stop	1
100-2336	Sostegno anta Wing support	3
100-1339	Incontro doppio Double rest plate	4
100-2114	Terminale aste Rod terminal	2
100-2111	Catenaccio "GIAP" "GIAP" latch	4
100-2328	Drenaggio acqua Water drainage	4
137-90071	Clip per fermavetri arrotondati Clips for rounded glass beading	30

* Var. squadrette a cianfrinare o spinare
Version corner joints locked by pin or chamfered

Guarnizioni

Gaskets

Art. Item	N°. pezzi Pcs
126-2666	3L+6H
126-2178	2L+6H
126-2195	2L+6H
126-2261	2L+4H
126-4147	4

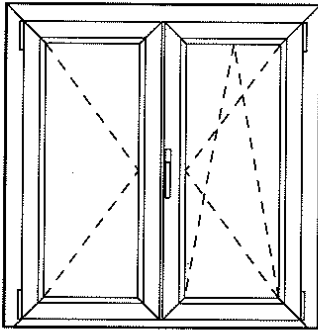

Note - Notes:





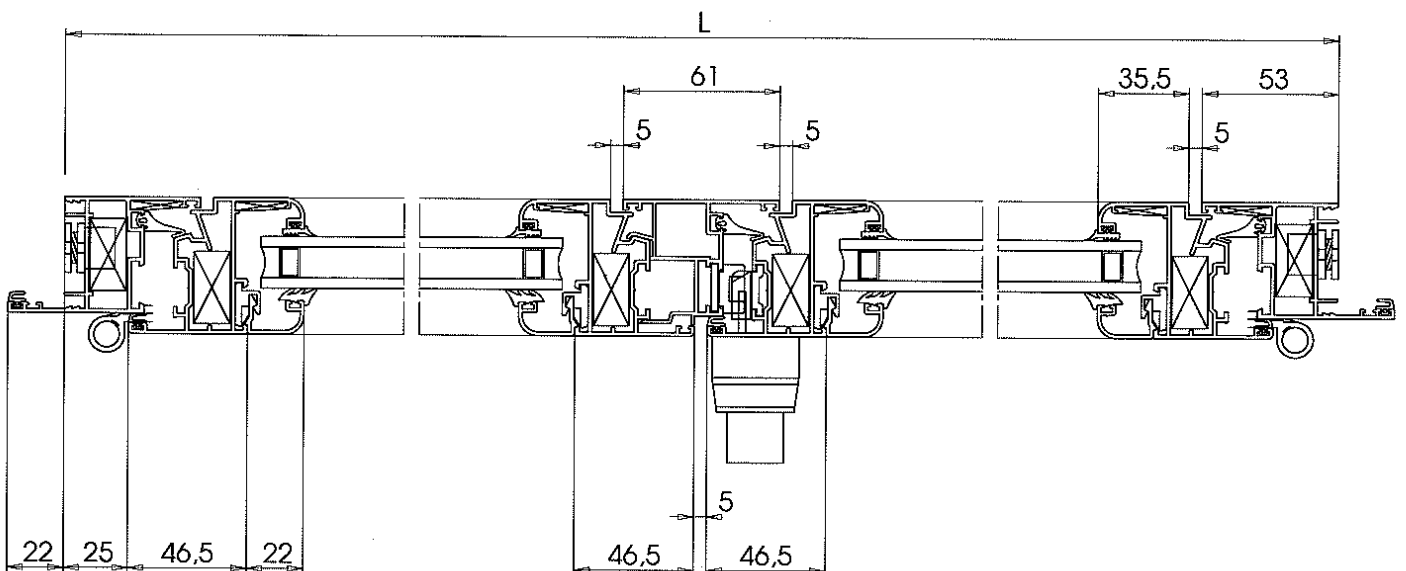
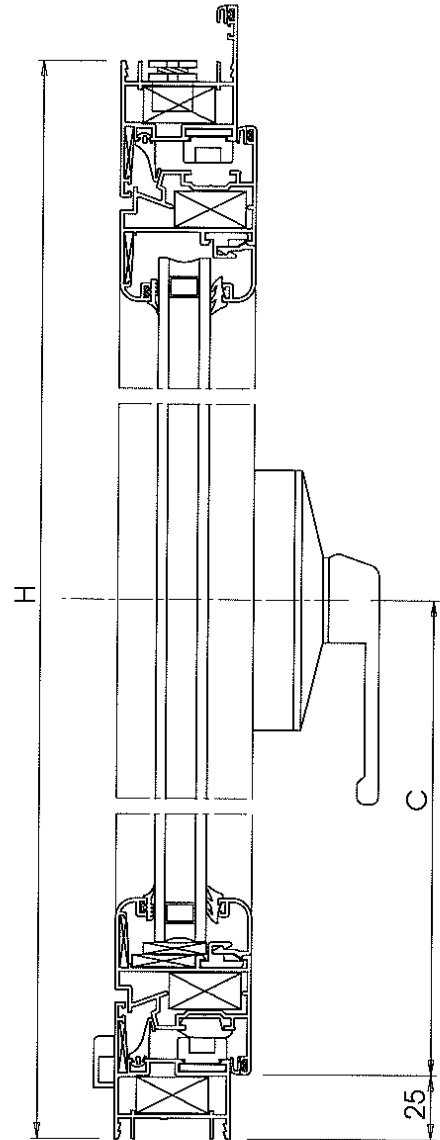

Spessore vetro considerato mm 20
 For glass with 20 mm thickness

Gioco perimetrale tra profilo
 e vetro mm 8 minimo
 Space between glass and profile 8 mm minimum

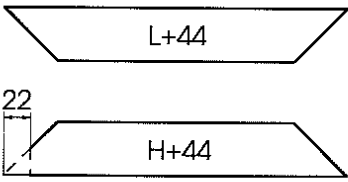
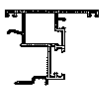
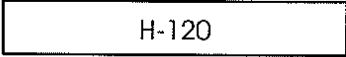
Vetri N° 2 pezzi
 Glasses N°2 pieces

$$((L - 273)/2) (H-159)$$

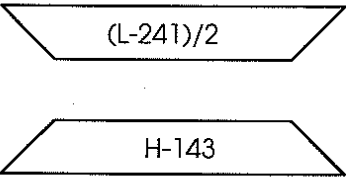
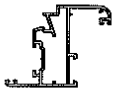
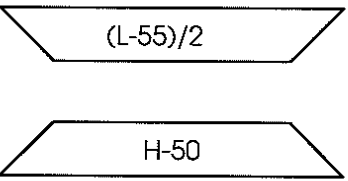

Profilo Profile	N° Pezzi Pcs	Schema di taglio Preparation	Profilo Profile	N° Pezzi Pcs	Schema di taglio Preparation
 7012	1 2		 4263	1	
 7011	1		 4290	4 4	
 4265	4 4		 6405	Vedi istruzioni nel kit See instructions on the kit	

Accessori Accessories			Accessori Accessories			Guarnizioni Gaskets	
Art. Item	Descrizione Description	N°. pezzi Pcs	Art. Item	Descrizione Description	N°. pezzi Pcs	Art. Item	N°. pezzi Pcs
104-600.01	Espansore Adjustable block	8	100-2336	Sostegno anta Wing support	1	126-2666	3L+5H
* 105-0409	Squadretta a scatto Corner joint	12	100-1339	Incontro doppio Double rest plate	1	126-2178	2L+4H
126-6137	Squad. allin.to telaio-anta Corner joint frame-wing	12	100-1314	Incontro Rest plate	1	126-2195	2L+4H
105-0706	Squadretta inox telaio Corner joint frame	2	100-2328	Drenaggio acqua Water drainage	3	126-2261	2L+3H
137-93497	Tappi riporto centrale Seal plug on central prof.	1	137-90071	Clip per fermavetri arrotondati Clips for rounded glass beading	20	126-4147	4
100-4501	Kit base anta/ribalta Kit for tilt-turn	1	100-0120	Cerniera "FLASH" Hinge	2		
100-1090	Cremonese "EURO" "EURO" cremonese bolt	1					
100-4221	Braccio medio tipo 2 Middle arm type 2	1					
100-4261	Kit chiusura doppia anta Kit lock for double wing	1					

* Var. squadrette a cianfrinare o spinare
Version corner joints locked by pin or chamfered

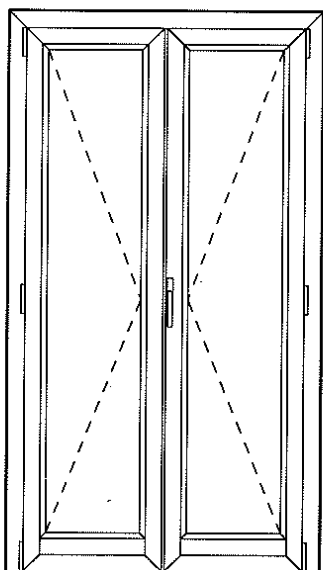









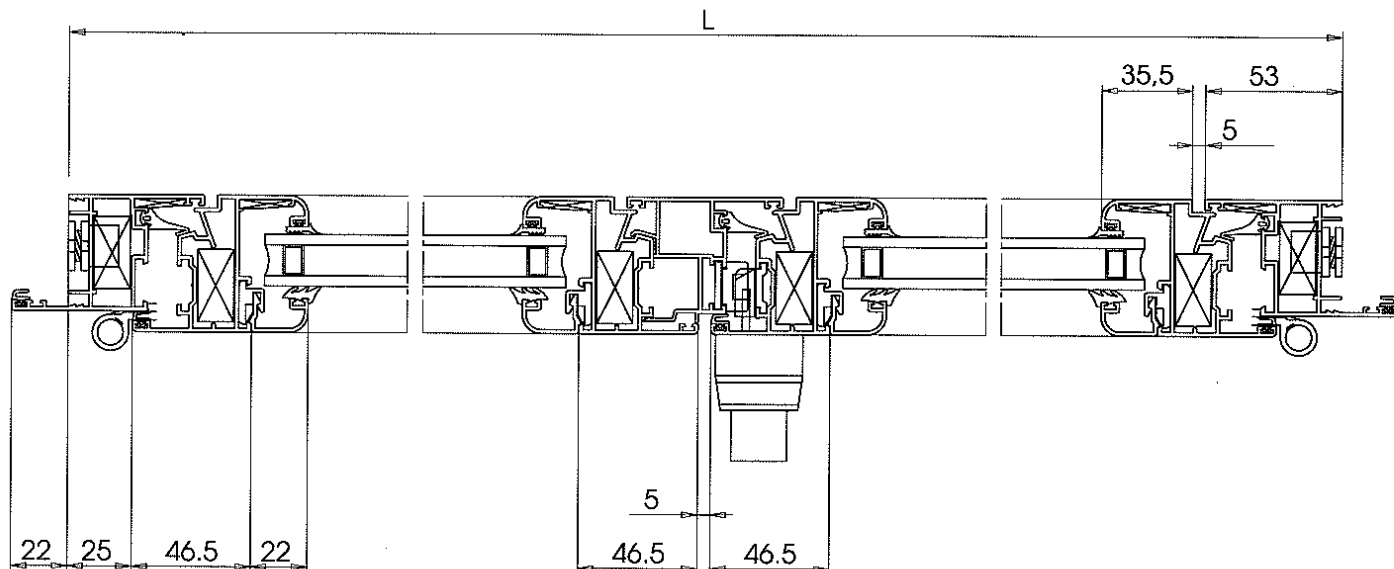
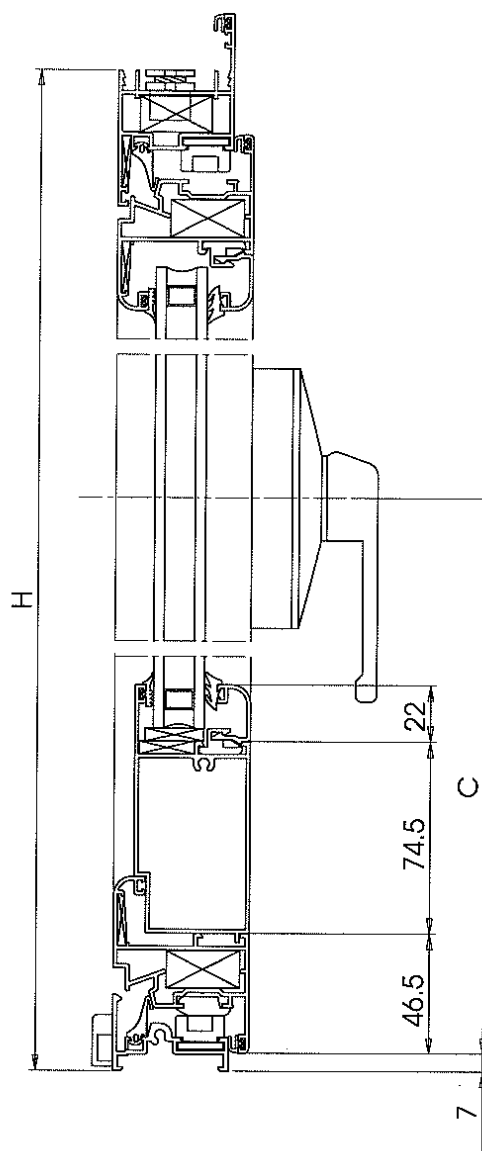

Note - Notes:

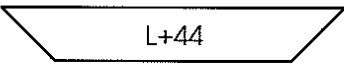
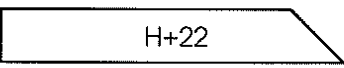
Spessore vetro considerato mm 20
For glass with 20 mm thickness

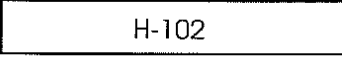
Gioco perimetrale tra profilo
e vetro mm 8 minimo
Space between glass and profile 8 mm minimum

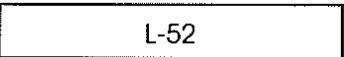
Vetri N° 2 pezzi
Glasses N°2 pieces
 $((L - 273)/2)$ (H-215.5)

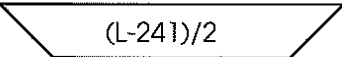
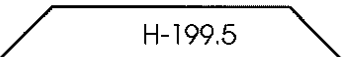
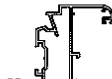
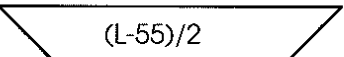
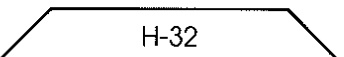

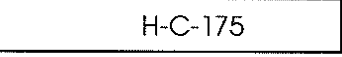
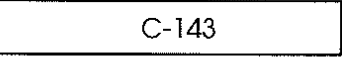
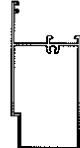
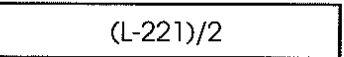
Profilo Profile	N° Pezzi Pcs	Schema di taglio Preparation	Profilo Profile	N° Pezzi Pcs	Schema di taglio Preparation
 7012	1 2	 L+44  H+22	 4263	1	 H-102
 4271	1	 L-52	 4290	4 4	 (L-241)/2  H-199.5
 4265	4 4	 (L-55)/2  H-32	 6405	1 1	 H-C-175  C-143
 4286	2	 (L-221)/2			

Accessori
Accessories

Art. Item	Descrizione Description	N° pezzi Pcs
104-600.01	Espansore Adjustable block	10
* 105-0409	Squadretta a scatto Corner joint	10
126-6137	Squad. allin.to telaio-anta Corner joint frame-wing	10
105-0706	Squadretta inox telaio Corner joint frame	2
137-93497	Tappi riporto centrale Seal plug on central prof.	1
100-0120X	Cerniera "FLASH" Hinge	6
100-1000	Cremonese "EURO" "EURO" cremone bolt	1
100-2387	Blocchetti collegamento Connections blocks	1
100-1314	Incontro 3° chiusura Rest plate for 3rd stop	1

Accessori
Accessories

Art. Item	Descrizione Description	N° pezzi Pcs
100-2336	Sostegno anta Wing support	2
100-1339	Incontro doppio Double rest plate	2
100-2114	Terminale aste Rod terminal	2
100-2111	Catenaccio "GIAP" "GIAP" latch	2
100-2328	Drenaggio acqua Water drainage	3
137-90071	Clip per fermavetri arrotondati Clips for rounded glass beading	24

Guarnizioni
Gaskets

Art. Item	N° pezzi Pcs
126-2666	3L+5H
126-2178	2L+4H
126-2195	2L+4H
126-2261	2L+3H
126-4147	4

* Var. squadrette a cianfrinare o spinare
Version corner joints locked by pin or chamfered

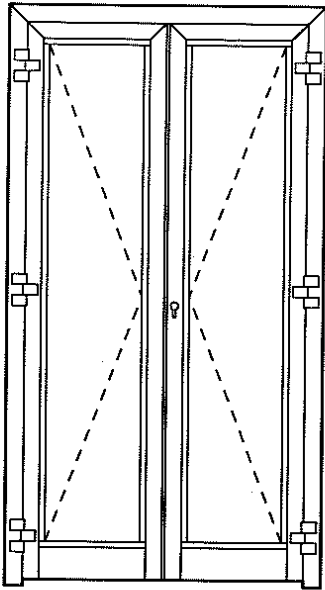







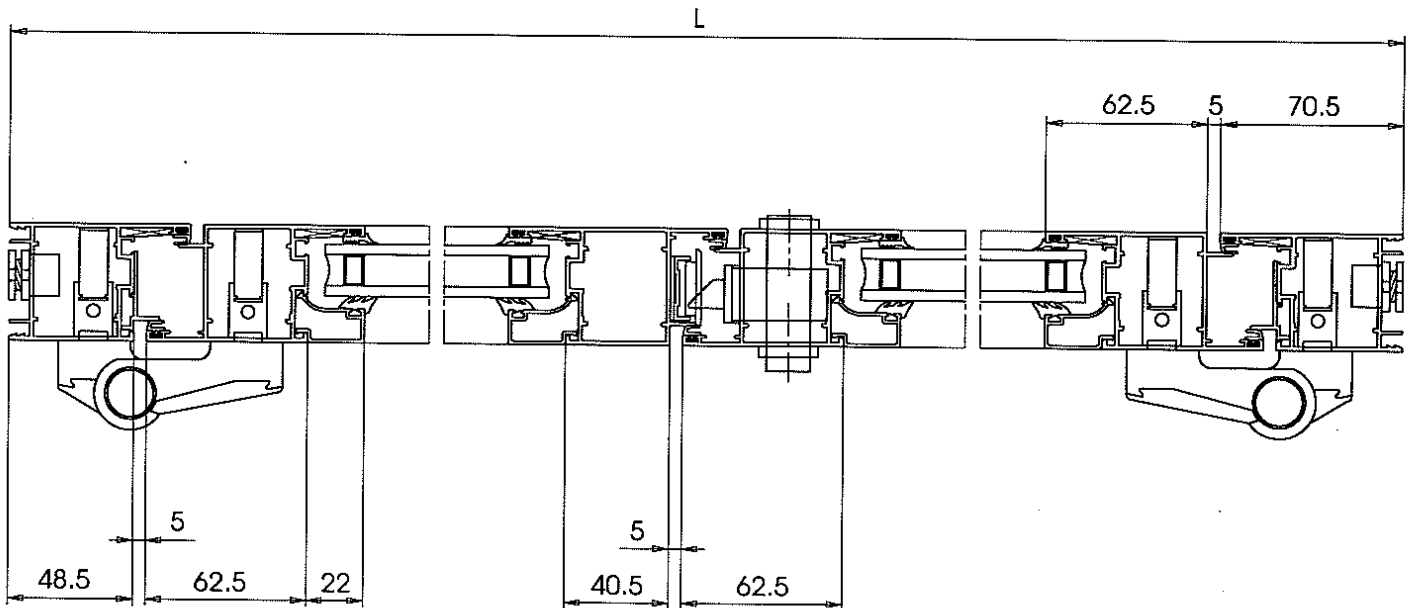
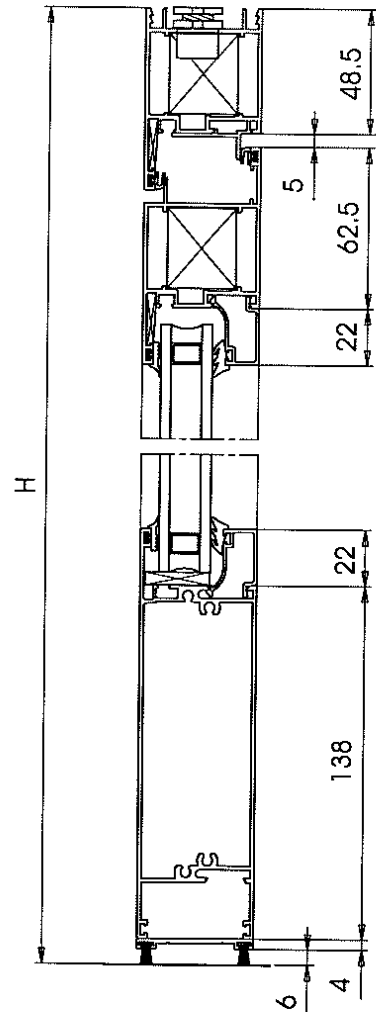

Note - Notes:

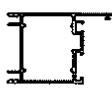
Spessore vetro considerato mm 20
 For glass with 20 mm thickness

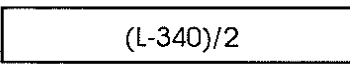
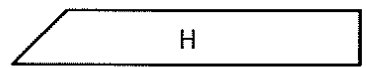
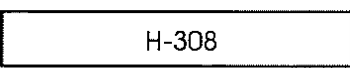
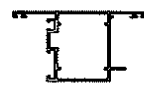
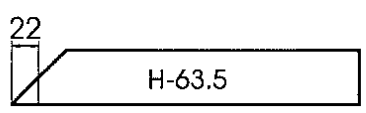
Gioco perimetrale tra profilo
 e vetro mm 5 minimo
 Space between glass and profile 5 mm minimum

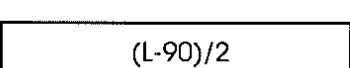
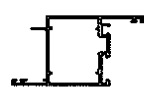
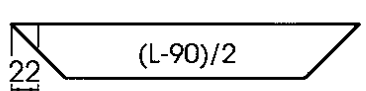
Vetri N° 2 pezzi
 Glasses N°2 pieces
 (L - 360)/2 (H-274)

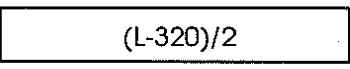
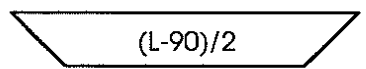
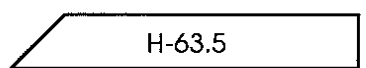

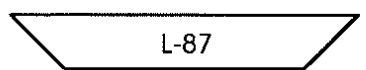
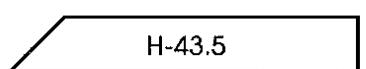
Profilo Profile	N° Pezzi Pcs	Schema di taglio Preparation	Profilo Profile	N° Pezzi Pcs	Schema di taglio Preparation
 9035	1	 L	 4294	4	 (L-340)/2
	2	 H		4	 H-308
 6039	1	 H-63.5	 7015	2	 (L-90)/2
 6038	1	 (L-90)/2	 4288	2	 (L-320)/2
	1	 (L-90)/2			
	3	 H-63.5			
 5633	1	 L-87			
	2	 H-43.5			

Accessori Accessories			Accessori Accessories			Guarnizioni Gaskets	
Art. Item	Descrizione Description	N° pezzi Pcs	Art. Item	Descrizione Description	N° pezzi Pcs	Art. Item	N° pezzi Pcs
104-600.01	Espansore Adjustable block	8				126-2666	2L+6H
* 110-3578	Squadretta Corner	6				126-2178	2L+4H
210-T2974	Spina Pin	12				126-2195	2L+4H
126-6137	Squad. allin.to telaio-anta Corner joint frame-wing	6				619-PB59	2L
126-6117	Tappi d'inv. centrale Seal plug on central profile	1					
101-6045	Cerniera "LOIRA" Hinge "LOIRA"	6					
100-1325	Incontro catenaccio Rest plate latch	1					
100-2170	Catenaccio Latch	2					
100-2159	Boccola per soglia Door sill bush	1					
			* Var. squadrette a cianfrinare Version corner joints chamfered				

PORTA A DUE ANTE-APERTURA ESTERNA
TWO WING DOOR-EXTERNAL OPENING

90

GENNAIO 2000

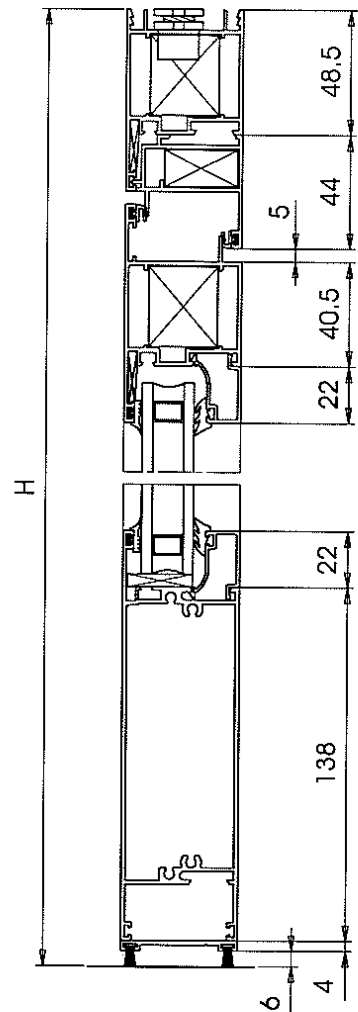
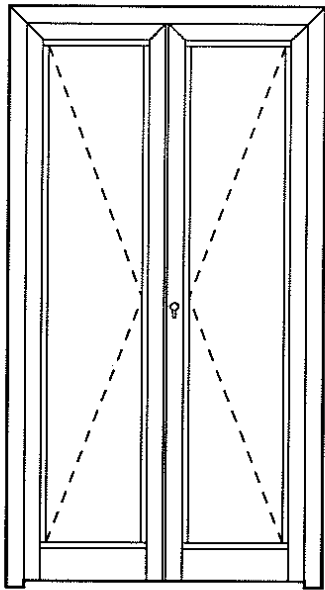





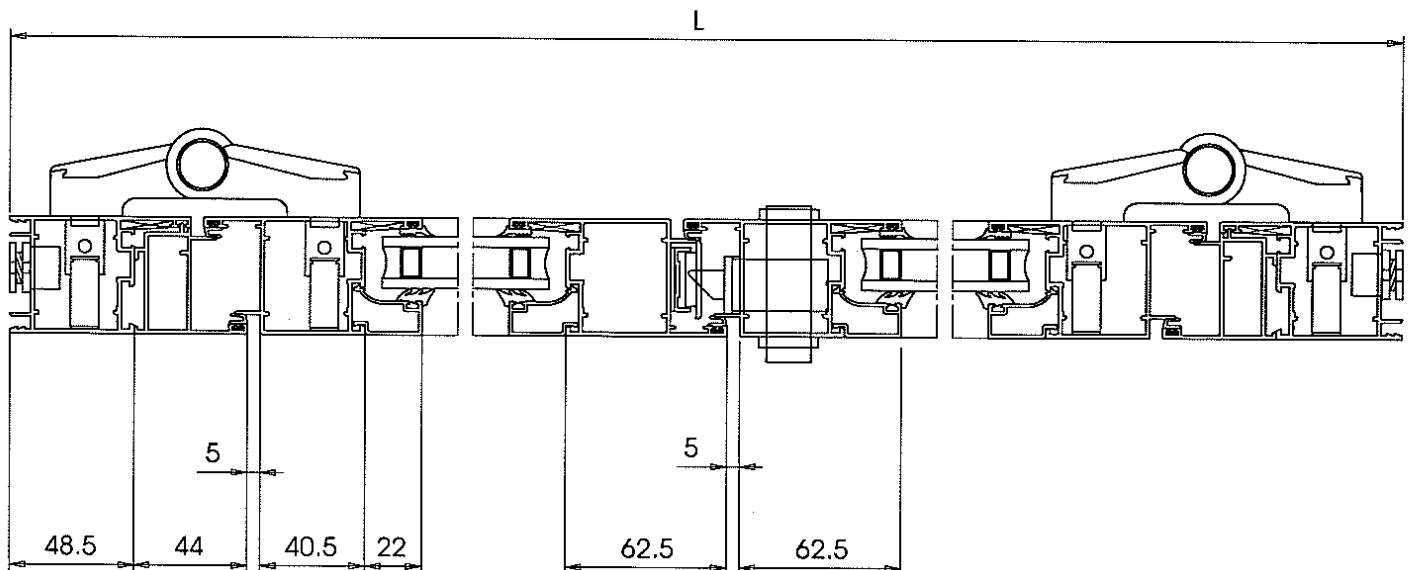

Note - Notes:

Spessore vetro considerato mm 20
 For glass with 20 mm thickness

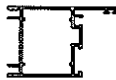
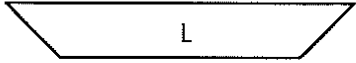
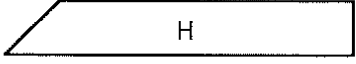
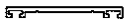
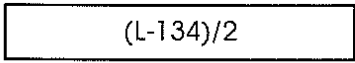
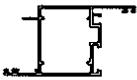
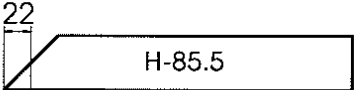
Gioco perimetrale tra profilo
 e vetro mm 5 minimo
 Space between glass and profile 5 mm minimum

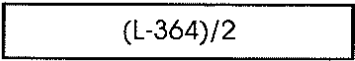
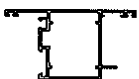
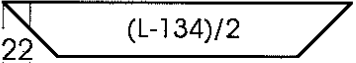
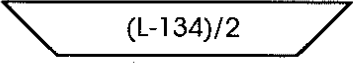
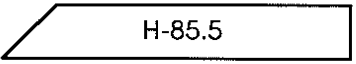
Vetri N° 2 pezzi
 Glasses N°2 pieces
 (L-404)/2 (H-296)

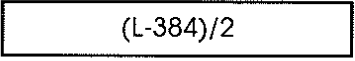
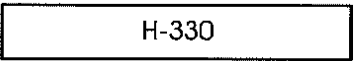

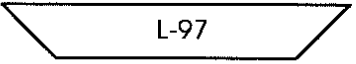
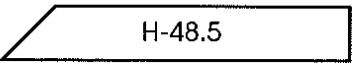
Profilo Profile	N° Pezzi Pcs	Schema di taglio Preparation	Profilo Profile	N° Pezzi Pcs	Schema di taglio Preparation
 9035	1 2	 L  H	 7015	2	 (L-134)/2
 6038	1	 H-85.5	 4288	2	 (L-364)/2
 6039	1 1 3	 (L-134)/2  (L-134)/2  H-85.5	 4294	4 4	 (L-384)/2  H-330
 6040	1 2	 L-97  H-48.5			

Accessori Accessories			Accessori Accessories			Guarnizioni Gaskets	
Art. Item	Descrizione Description	N° pezzi Pcs	Art. Item	Descrizione Description	N° pezzi Pcs	Art. Item	N° pezzi Pcs
104-600.01	Espansore Adjustable block	10	100-2159	Boccola per soglia Door sill bush	1	126-2666	2L+6H
110-3578	Squadretta Corner	6				126-2178	2L+4H
210-T2974	Spina Pin	12				126-2195	2L+4H
* 105-0409	Squadretta a scatto Corner joint	2				619-PB59	2L
126-6137	Squad. allin.to telaio-anta Corner joint frame-wing	6					
126-6117	Tappi d'inv. centrale Seal plug on central profile	1					
101-6197	Cerniera "LOIRA" Hinge "LOIRA"	6					
100-1325	Incontro catenaccio Rest plate latch	1					
100-2170	Catenaccio Latch	2					

* Var. squadrette a cianfrinare o spinare
Version corner joints locked by pin or chamfered

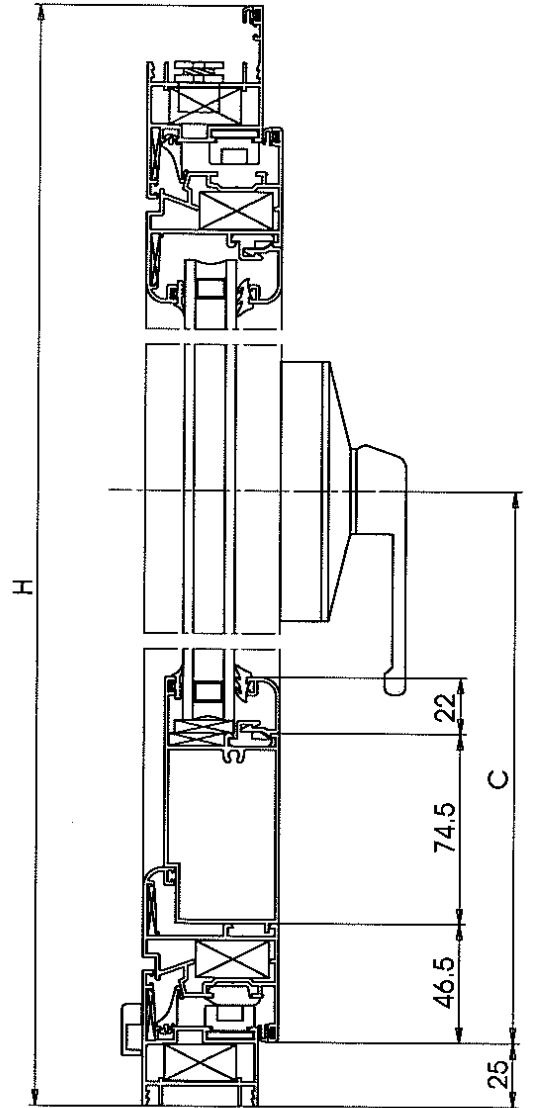
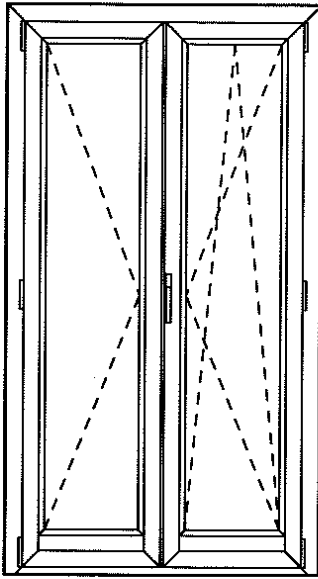









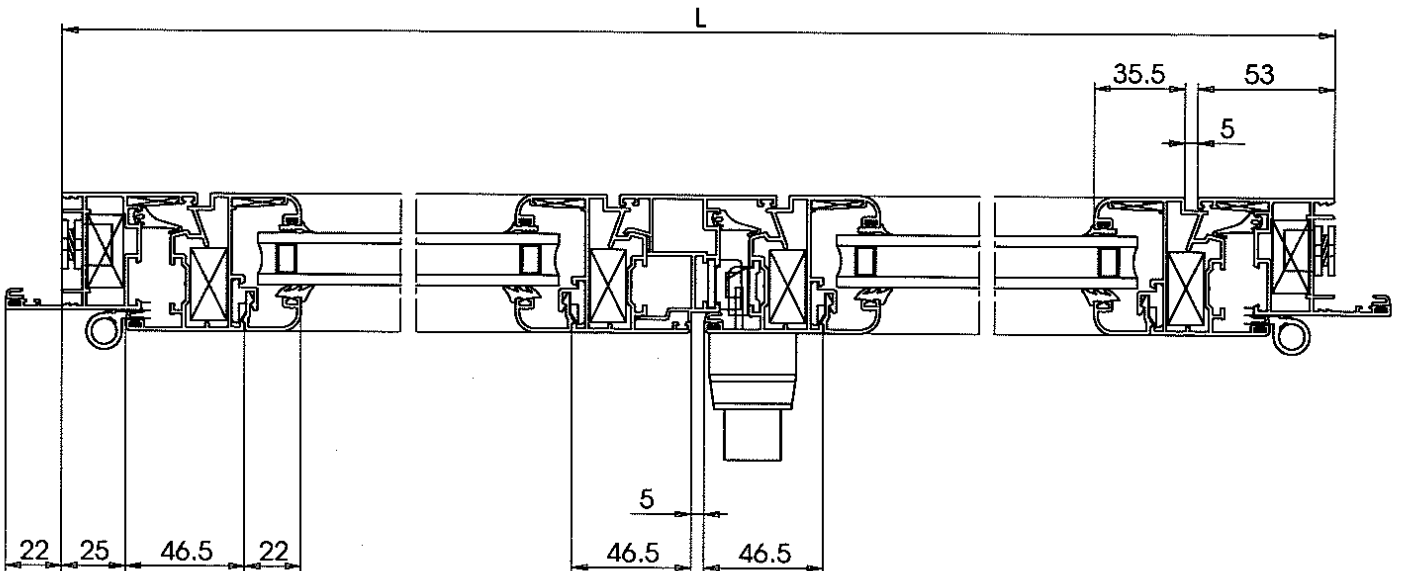

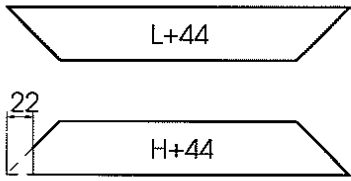

Note - Notes:

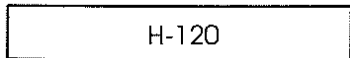
Spessore vetro considerato mm 20
 For glass with 20 mm thickness

Gioco perimetrale tra profilo
 e vetro mm 8 minimo
 Space between glass and profile 8 mm minimum

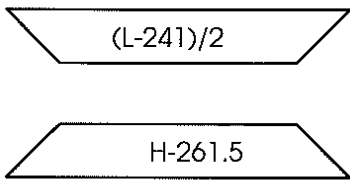
Vetri N° 2 pezzi
 Glasses N°2 pieces
 $[(L - 273)/2]$ (H-233.5)

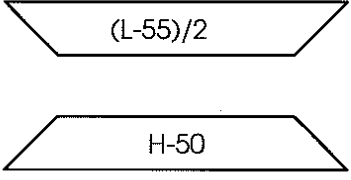

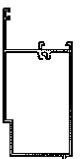
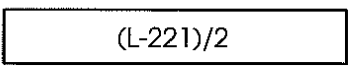
Profilo Profile	N° Pezzi Pcs	Schema di taglio Preparation	Profilo Profile	N° Pezzi Pcs	Schema di taglio Preparation
 7012	1 2		 4263	1	
 7011	1		 4290	4 4	
 4265	4 4		 6405	Vedi istruzioni nel kit See instruction on the kit	
 4286	2				

Accessori Accessories			Accessori Accessories			Guarnizioni Gaskets	
Art. Item	Descrizione Description	N°. pezzi Pcs	Art. Item	Descrizione Description	N°. pezzi Pcs	Art. Item	N°. pezzi Pcs
104-600.01	Espansore Adjustable block	10	100-4261	Kit chiusura doppia anta Kit lock for double wing	1	126-2666	3L+5H
* 105-0409	Squadretta a scatto Corner joint	12	100-2336	Sostegno anta Wing support	1	126-2178	2L+4H
126-6137	Squad. allin.to telaio-anta Corner joint frame-wing	12	100-1339	Incontro doppio Double rest plate	1	126-2195	2L+4H
105-0706	Squadretta inox telaio Corner joint frame	2	100-1314	Incontro Rest plate	1	126-2261	2L+3H
137-93497	Tappi riporto centrale Seal plug on central prof.	1	100-2328	Drenaggio acqua Water drainage	3	126-4147	2L
100-4501	Kit base anta/ribalta Kit for tilt-turn	1	137-90071	Clip per fermavetri arrotondati Clips for rounded glass beading	24		
100-1090	Cremonese "EURO" "EURO" cremone	1					
100-4221	Braccio medio tipo 2 Middle arm type 2	1					
100-4241	Chiusura suppl. vert. Additional vertical lock	1					

* Var. squadrette a cianfrinare o spinare
Version corner joints locked by pin or chamfered

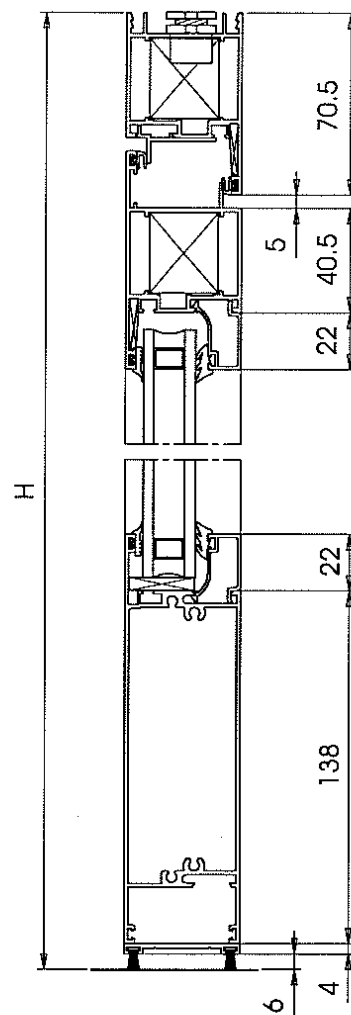
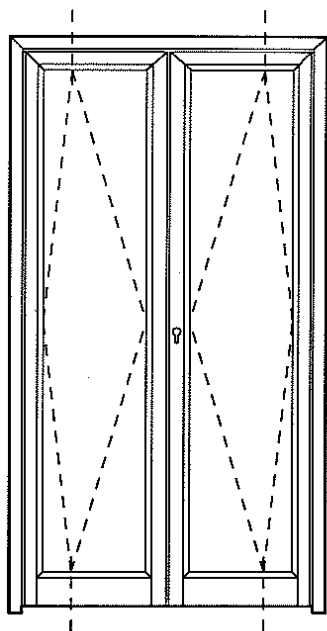







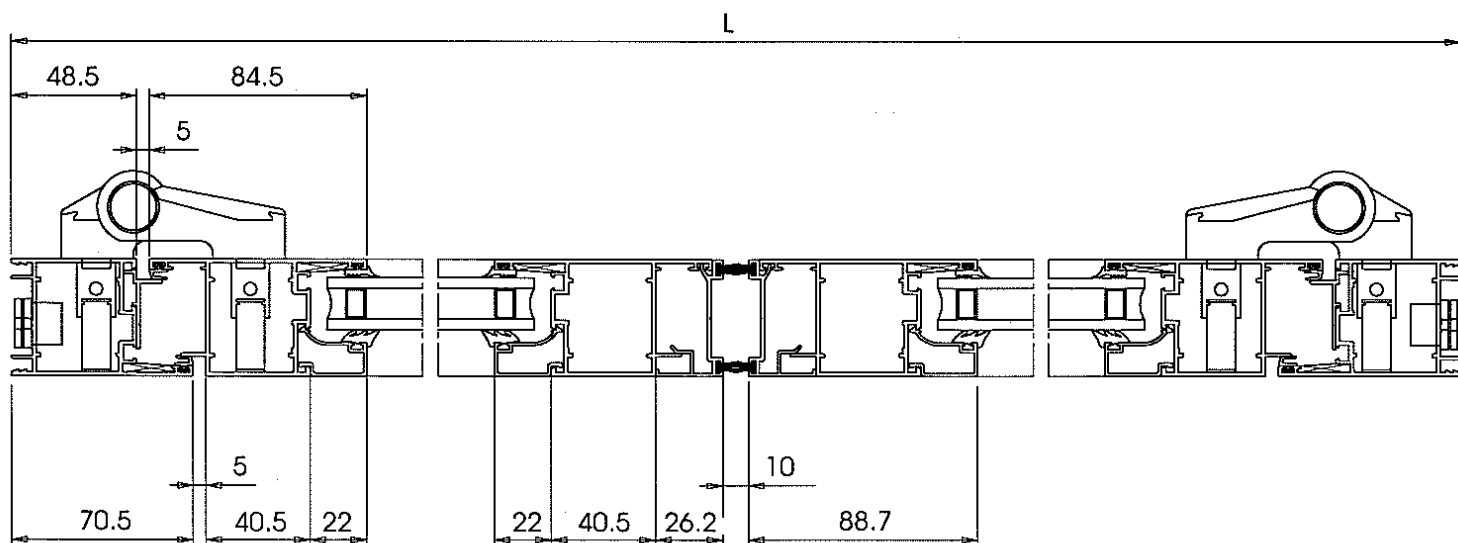

Note - Notes:

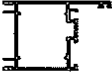
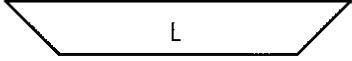
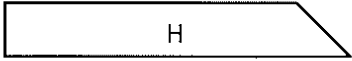
Spessore vetro considerato mm 20
For glass with 20 mm thickness

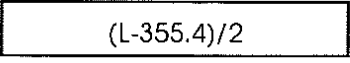
Gioco perimetrale tra profilo
e vetro mm 5 minimo
Space between glass and profile 5 mm minimo

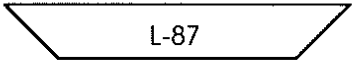
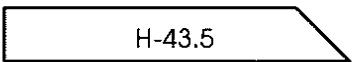
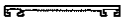
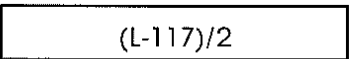
Vetri N° 2 pezzi
Glasses N°2 pieces
 $(L - 395.5)/2$ (H-274)

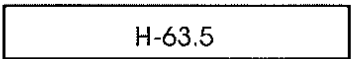

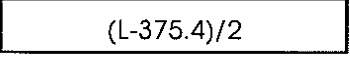
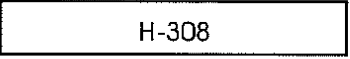
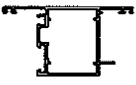
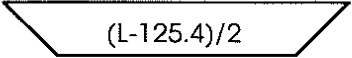
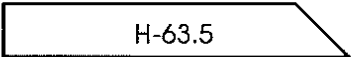
Profilo Profile	N° Pezzi Pcs	Schema di taglio Preparation	Profilo Profile	N° Pezzi Pcs	Schema di taglio Preparation
 9035	1 2	 L  H	 4288	2	 vedi lavorazioni sul catalogo
 5633	1 2	 L-87  H-43.5	 7015	2	 vedi lavorazioni sul catalogo
 7019	2	 H-63.5	 4294	4 4	  H-308
 6039	2 4	 (L-125.4)/2  H-63.5			

Accessori Accessories			Accessori Accessories			Guarnizioni Gaskets	
Art. Item	Descrizione Description	N° pezzi Pcs	Art. Item	Descrizione Description	N° pezzi Pcs	Art. Item	N° pezzi Pcs
104-600.01	Espansore Adjustable block	10				126-2666	2L+4H
* 110-3578	Squadretta Corner	6				126-2178	2L+4H
210-T2974	Spina Pin	12				126-2195	2L+4H
126-6137	Squad. allin.to telaio-anta Corner joint frame-wing	6				619-PB59	2L+4H
100-1325	Incontro catenaccio Rest plate latch	1					
100-2170	Catenaccio Latch	2					
100-2159	Boccola per soglia Door sill bush	1					
101-6045	Cerniera "LOIRA" Hinge "LOIRA"	6					

* Var. squadrette a cianfrinare o spinare
Version corner joints locked by pin or chamfered

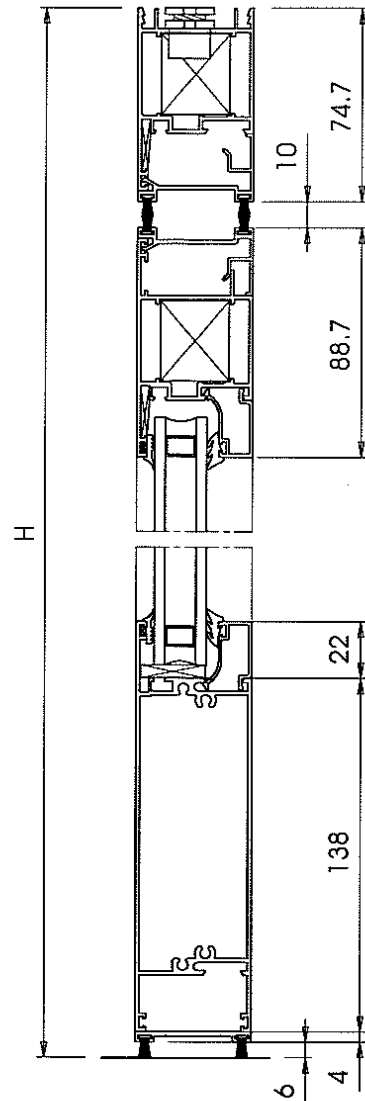
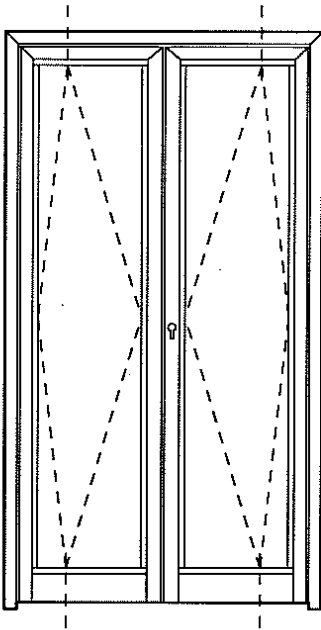





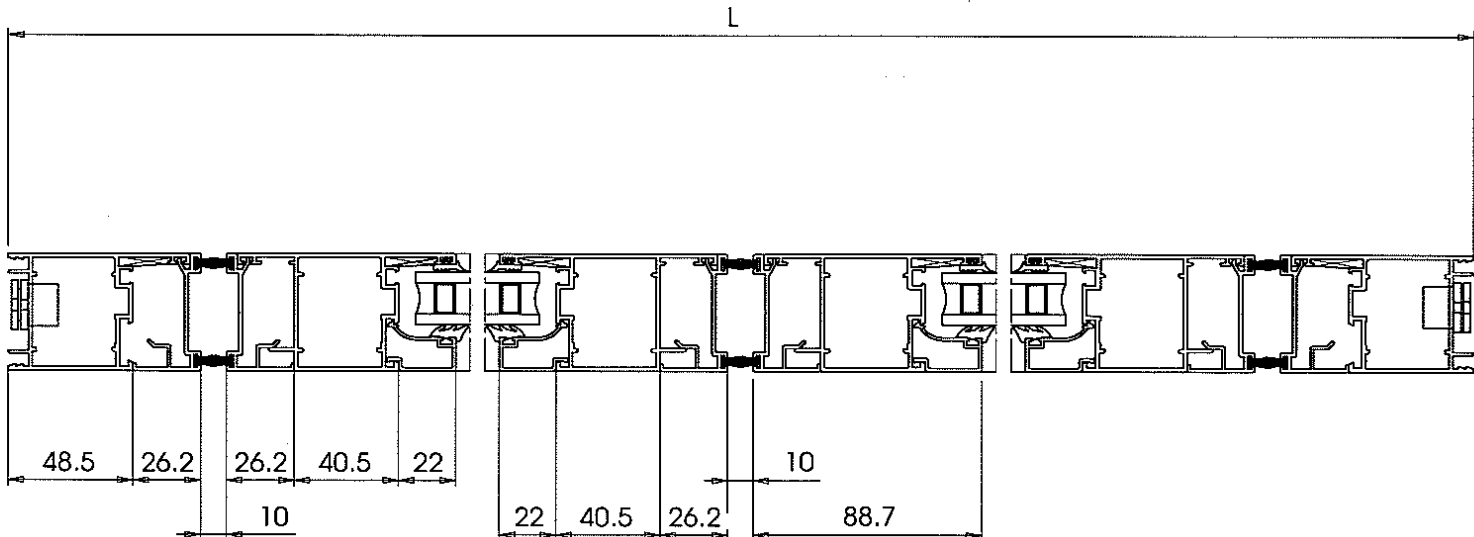

Note - Notes:

Spessore vetro considerato mm 20
 For glass with 20 mm thickness

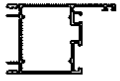
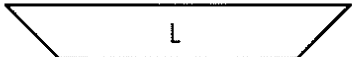
Gioco perimetrale tra profilo
 e vetro mm 5 minimo
 Space between glass and profile 5 mm minimum

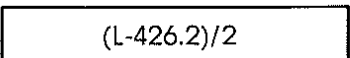
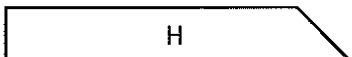
Vetri N° 2 pezzi
 Glasses N°2 pieces
 (L - 466)/2 (H-309.5)

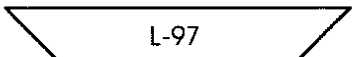
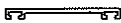
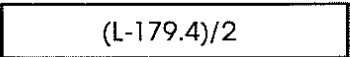
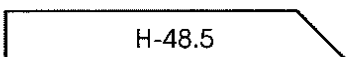
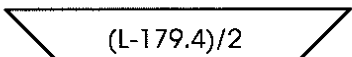

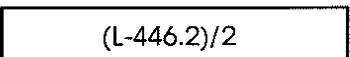
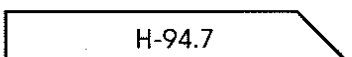
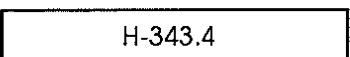
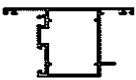
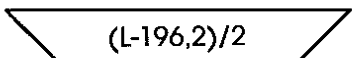
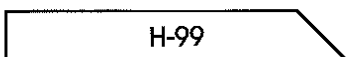
Profilo Profile	N° Pezzi Pcs	Schema di taglio Preparation	Profilo Profile	N° Pezzi Pcs	Schema di taglio Preparation
 9035	1	 L	 4288	2	 (L-426.2)/2 vedi lavorazioni sul catalogo
	2	 H			
 7019	1	 L-97	 7015	2	 (L-179.4)/2 vedi lavorazioni sul catalogo
	2	 H-48.5			
	2	 (L-179.4)/2	 4294	4	 (L-446.2)/2
	4	 H-94.7		4	 H-343.4
 6039	2	 (L-196.2)/2			
	4	 H-99			

Accessori Accessories			Accessori Accessories			Guarnizioni Gaskets	
Art. Item	Descrizione Description	N° pezzi Pcs	Art. Item	Descrizione Description	N° pezzi Pcs	Art. Item	N° pezzi Pcs
104-600.01	Espansore Adjustable block	10				126-2178	2L+4H
* 110-3578	Squadretta Corner	6				126-2195	2L+4H
210-T2974	Spina Pin	12				619-PB59	6L 12H
126-6137	Squad. allin.to telaio-anta Corner joint frame-wing	6					
100-1325	Incontro catenaccio Rest plate latch	1					
100-2170	Catenaccio Latch	2					
100-2159	Boccola per soglia Door sill bush	1					

* Var. squadrette a clanfrinare
* Version corner joints chamfered

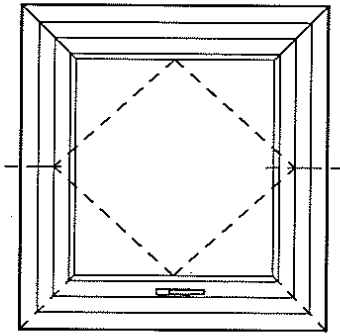









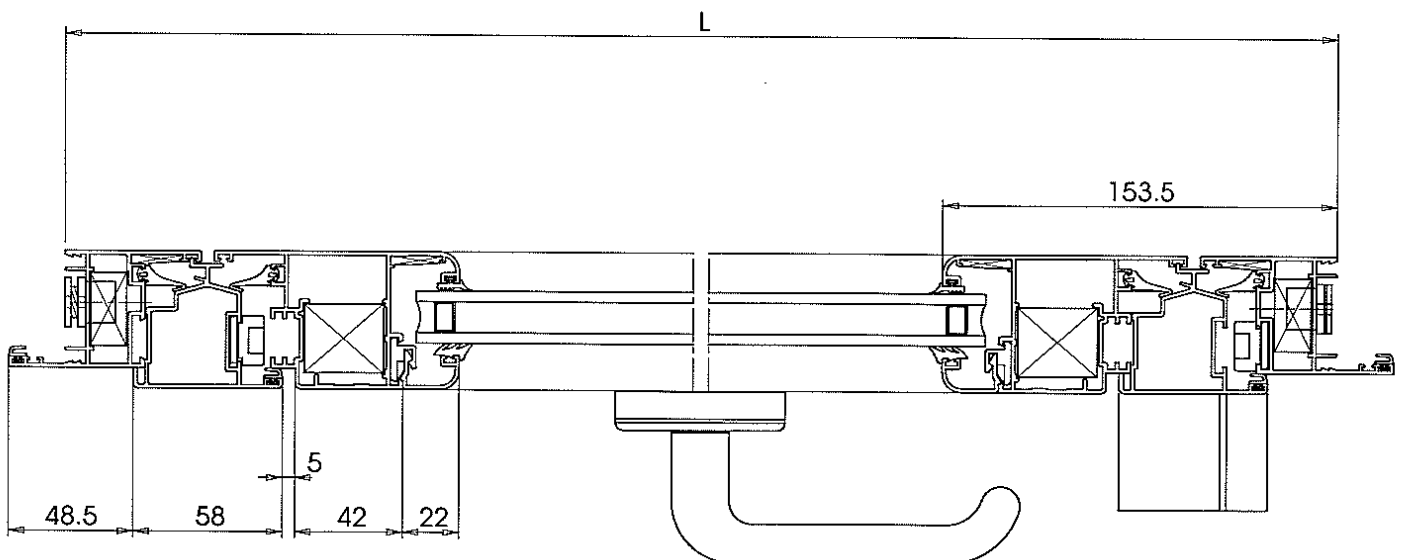
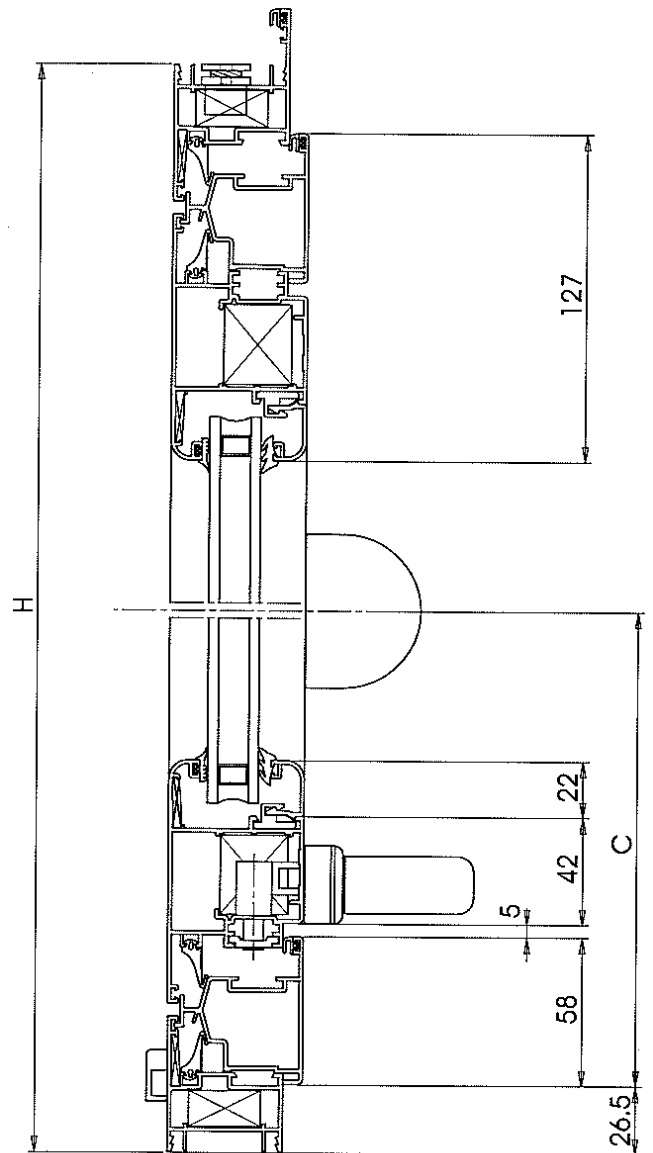

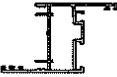
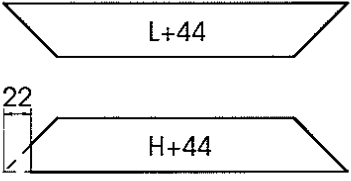
Note - Notes:

Spessore vetro considerato mm 20
 For glass with 20 mm thickness

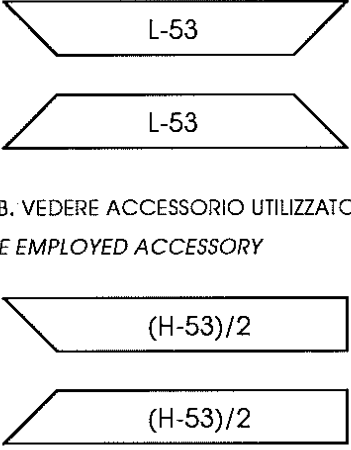
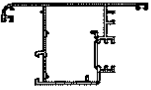
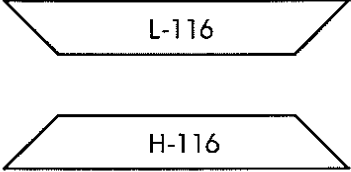
Gioco perimetrale tra profilo
 e vetro mm 8 minimo
 Space between glass and profile 8 mm minimum

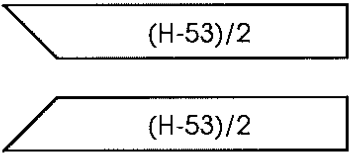
Vetri N° 1 pezzo per anta
 Glasses N°1 piece for wing
 (L-279) (H-279)

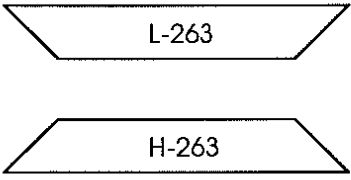

Profilo Profile	N° Pezzi Pcs	Schema di taglio Preparation	Profilo Profile	N° Pezzi Pcs	Schema di taglio Preparation
 7012	1 2		 7011	1	
 4280	1 1 2 2	 N.B. VEDERE ACCESSORIO UTILIZZATO SEE EMPLOYED ACCESSORY	 4281	2 2	
 4290	2 2		 4290	2 2	
 6405	1				

Accessori Accessories			Accessori Accessories			Guarnizioni Gaskets	
Art. Item	Descrizione Description	N°. pezzi Pcs	Art. Item	Descrizione Description	N°. pezzi Pcs	Art. Item	N°. pezzi Pcs
104-600.01	Espansore Adjustable block	7	100-2328	Drenaggio acqua Water drainage	2	126-2666	3L+4H
* 105-0409	Squadretta a scatto Corner joint	4	100-1314	Incontro Rest plate	2	126-2178	2L+2H
110-3578	Squadretta Corner joint	4	100-2114	Terminale aste Rod terminal	2	126-2195	2L+2H
210-T2974	Spina Pin	8	137-90071	Clip per fermavetri arrotondati Clips for rounded glass beading	12	126-2261	4L+4H
126-6137	Squad. allin.to telaio-anta Corner joint frame-wing	8	100-2252	Perno di trascinamento per art. 100-1025 Trailing pin for item 100-1025	2	126-4147	4
105-0706	Squadretta inox telaio Corner joint frame	2					
100-1458	Frizione per bilico Friction joint for pivot	1					
100-1025	Movim. bidirez.x bilico Bidirectional int. for pivot	1					
100-2460	Martellina "MASTERMAR" "MASTERMAR" handle	1					

* Var. squadrette a cianfrinare o spinare
Version corner joints locked by pin or chamfered

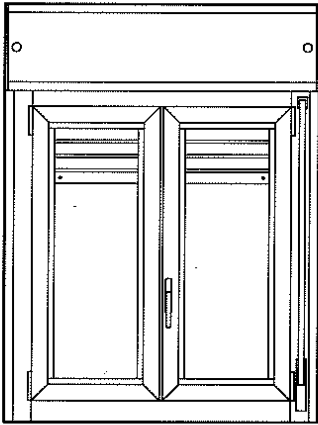

Note - Notes:

Spessore vetro considerato mm 20
For glass with 20 mm thickness







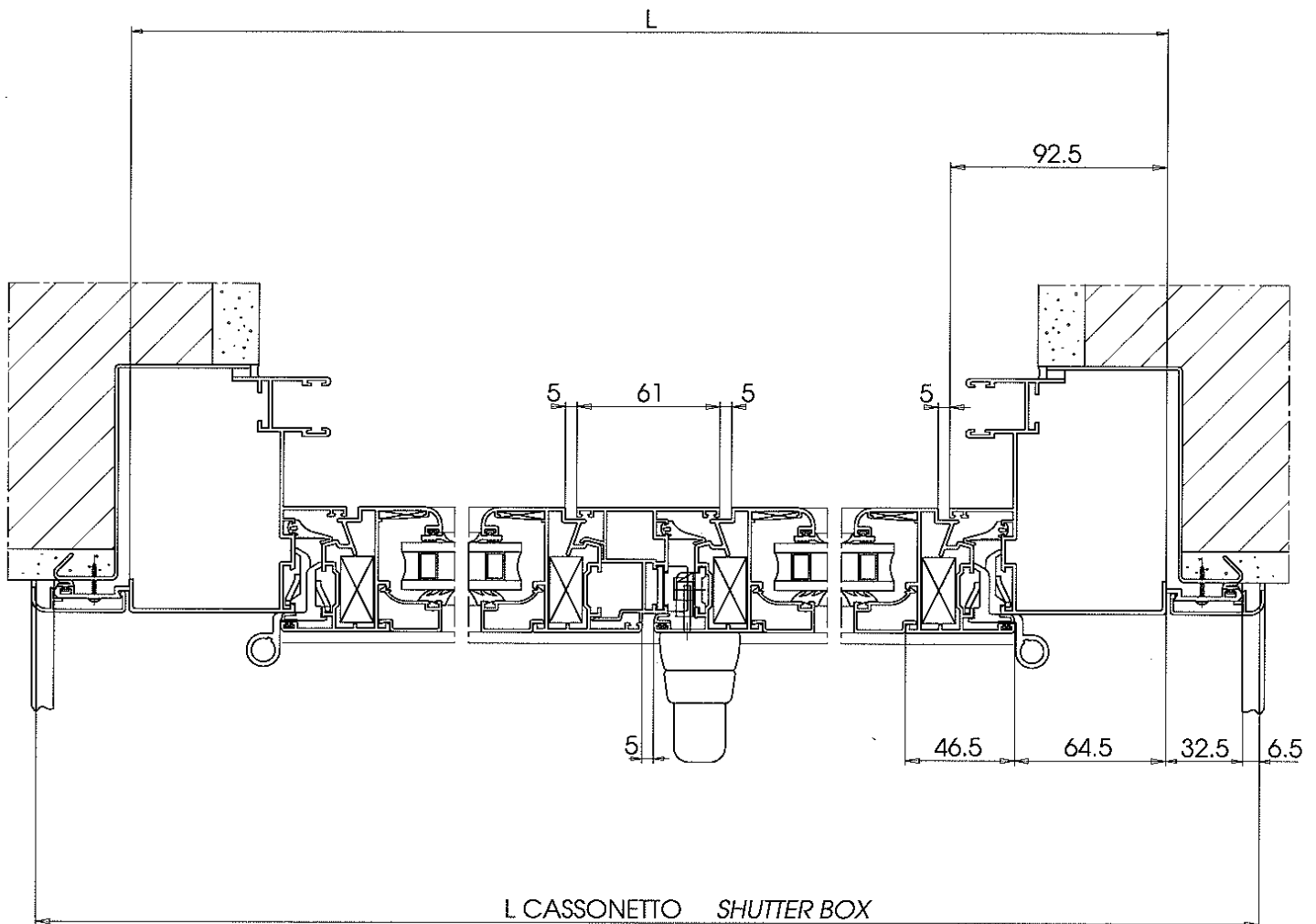

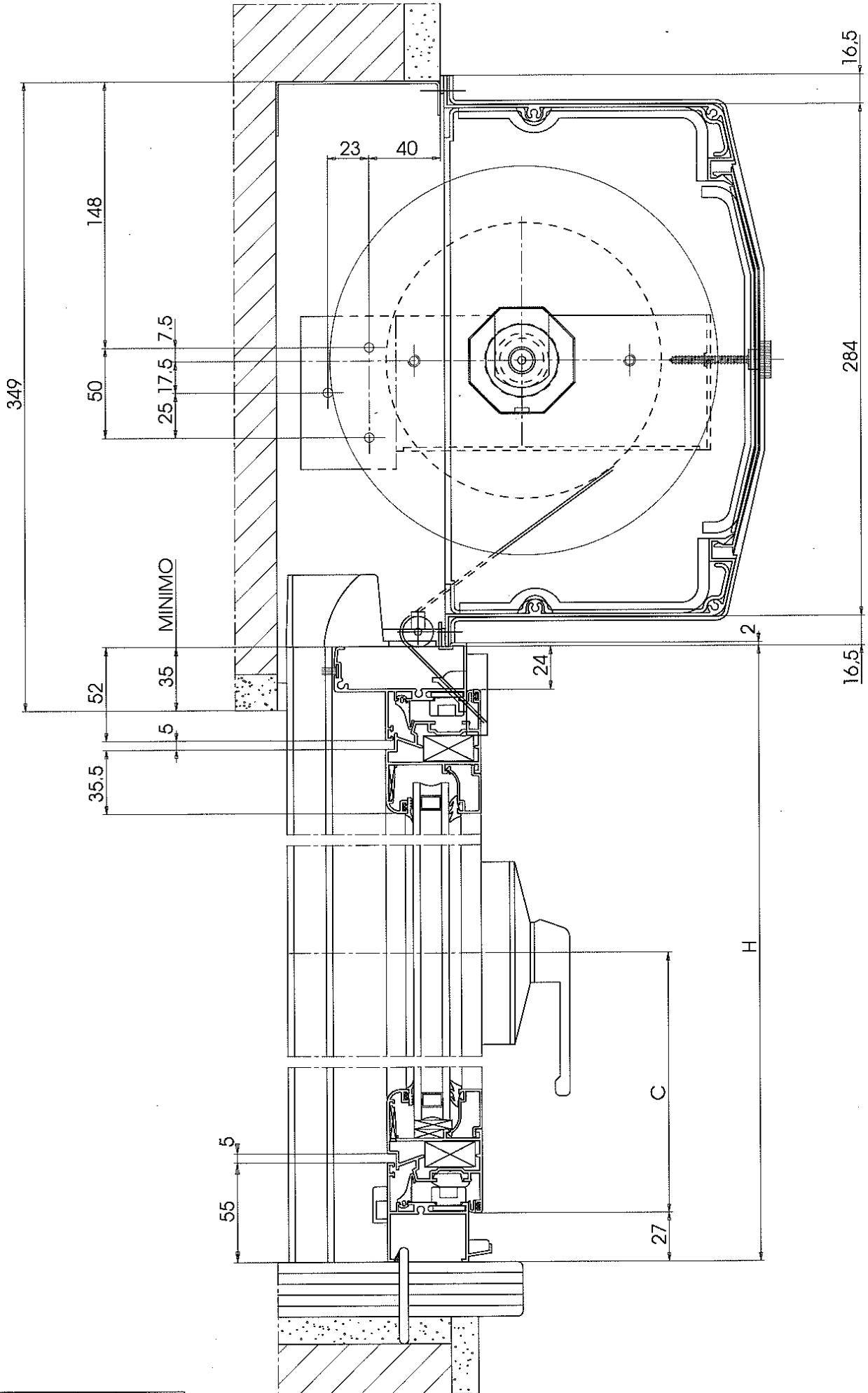

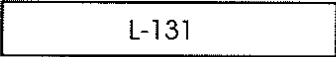
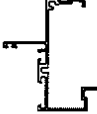
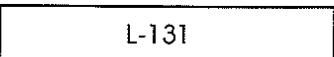

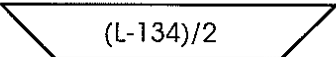
Gioco perimetrale tra profilo
e vetro mm 5 minimo
Space between glass and profile 5 mm minimum

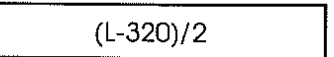
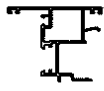
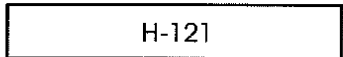
Vetri N° 2 pezzi
Glasses N°2 pieces

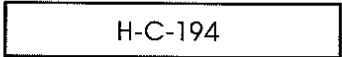
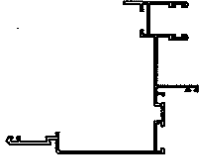
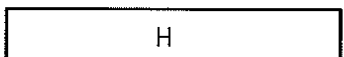
(L - 340)/2 (H - 134)

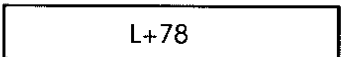

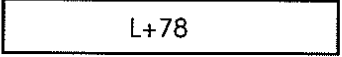

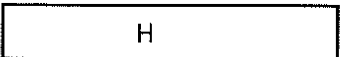
Profilo Profile	N° Pezzi Pcs	Schema di taglio Preparation	Profilo Profile	N° Pezzi Pcs	Schema di taglio Preparation
 6023	1	 L-131	 6022	1	 L-131
 4265	4	 (L-134)/2	 4294	4	 (L-320)/2
 4263	1	 H-121	 6405	1	 H-C-194
 6021	2	 H	 6013	2	 L+78
			 6014	1	 L+78
			 6024	2	 H

Accessori
Accessories

Art. Item	Descrizione Description	N°.pezzi Pcs
* 105-0409	Squadretta a scatto Corner joint	8
126-6137	Squad. allin.to anta Corner joint wing	8
136-1123	Cerniera speciale Special hinge	4
100-1000	Cremonese "EURO" "EURO" cremonese bolt	1
100-2387	Blocchetti colleg. Connection blocks	1
137-93497	Tappo riparto centrale Plug for central profile	1
100-1314	Incontro Rest plate	1
100-1339	Incontro doppio Double rest plate	2
100-2336	Sostegno anta Wing support	2
100-2111	Catenaccio "GIAP" "GIAP" latch	2

Accessori
Accessories

Art. Item	Descrizione Description	N°.pezzi Pcs
100-2114	Terminale aste Rod terminal	2
100-2328	Drenaggio acqua Water drainage	3
131-8973	Tappi cassonetto Plug for monoblock	1cp
131-8998	Mensole orizzontali Horizontal shelves	1cp
131-RA546	Avvolgitore Winder	1
131-PR9064	Inviti tapparella Plug for shutter	1cp
131-RA442	Pomolini con vite Knobs with screw	1cp
131-RA552	Cuscinetto a sfera Ball bearing	2
131-RA548	Cassetta per avvolgitore Winder housing	1

* Var. squadrette a cianfrinare o spinare
Version corner joints locked by pin or chamfered

Guarnizioni
Gaskets

Art. Item	N°.pezzi Pcs
126-2666	2L 5H
126-2178	2L 4H
126-2195	2L 4H
126-2261	2L 3H
126-4147	4

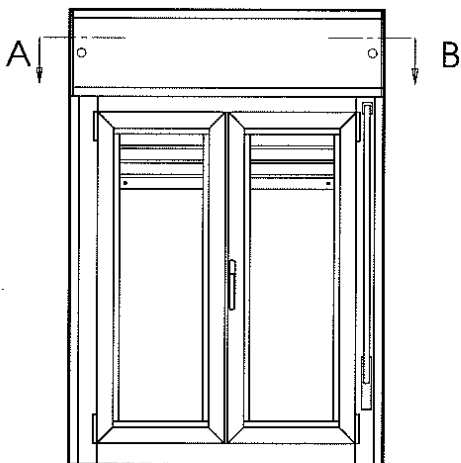
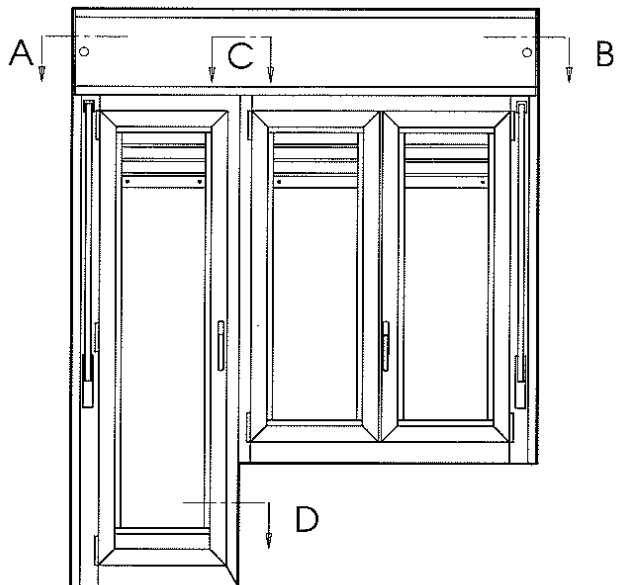

Art. 6A6.6813

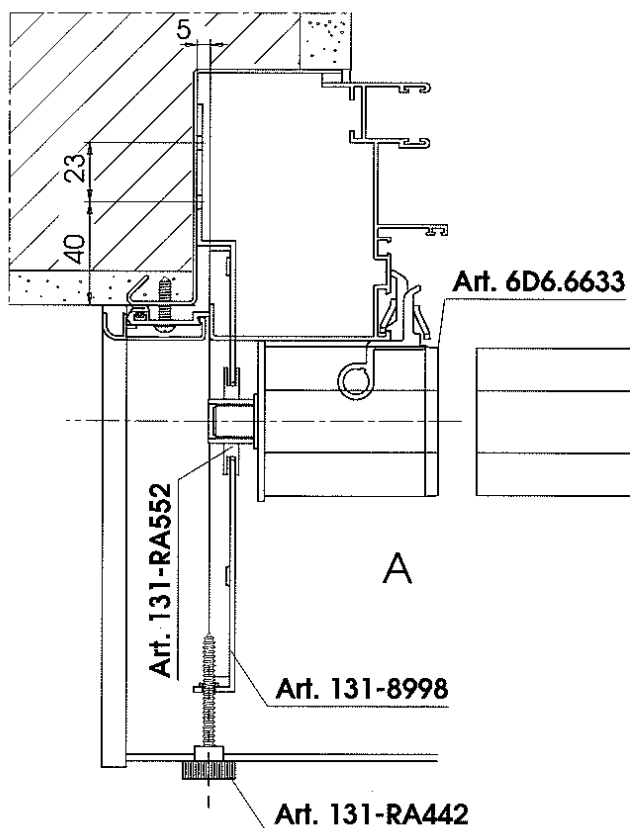
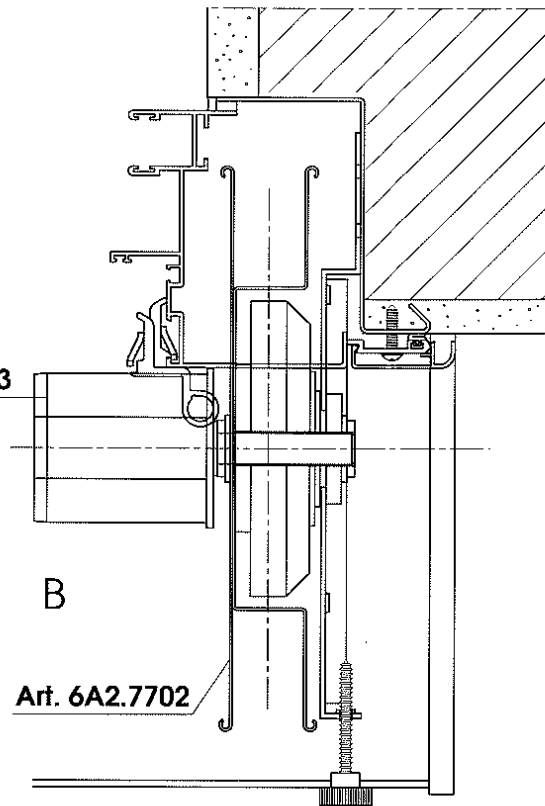

Art. 136-1123

Art. 6D5.3773

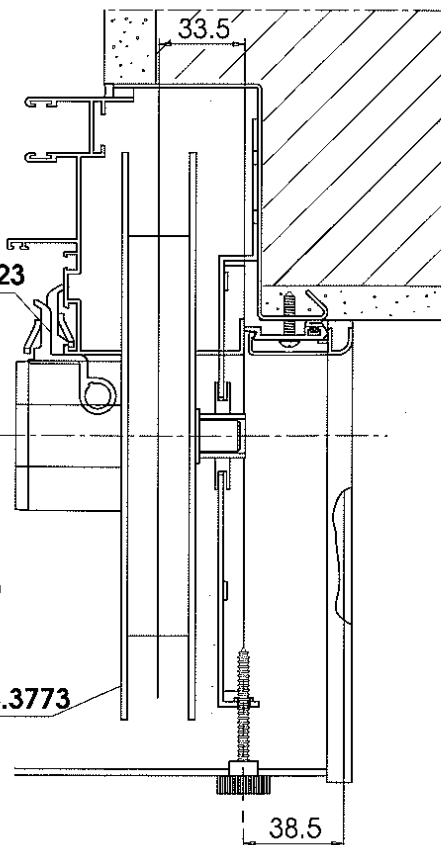

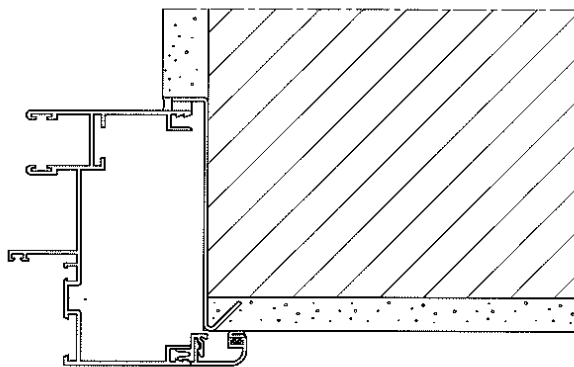
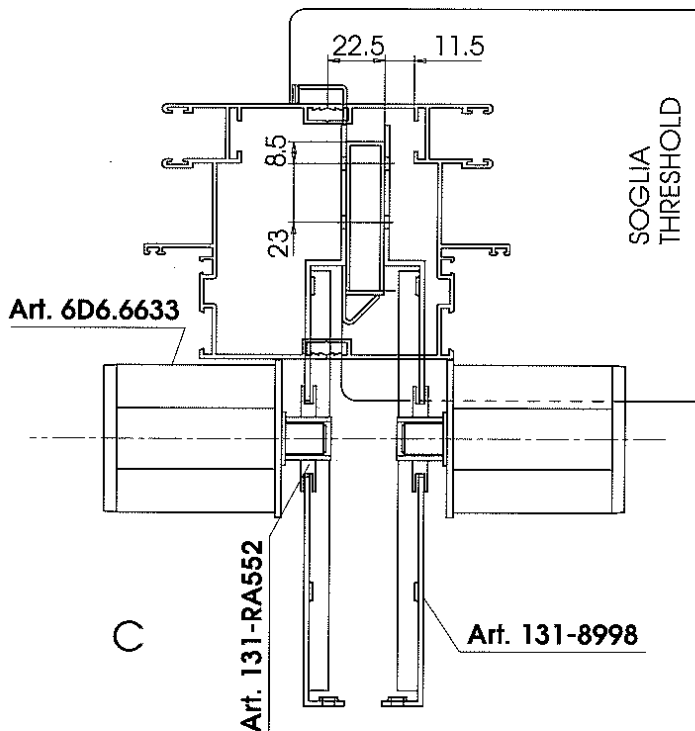



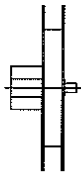

D

NB. GLI ACCESSORI A FIANCO INDICATI SONO DI PRODUZIONE STANDARD E NON A STOCK. VERRANNO FORNITI A RICHIESTA.

THE SHOWN ACCESSORIES ARE OF STANDARD PRODUCTION AND ARE SUPPLIED AT REQUEST.

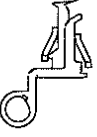
ARTICOLO ACCESSORI ITEM ACCESSORIES	DESCRIZIONE DESCRIPTION
6D5.3773 	PULEGGIA IN NYLON PORTATA Kg 18 NYLON PULLEY FOR 18 Kg Max
6A2.7702 	PULEGGIA CON RIDUTTORE PORTATA Kg 28 Max PULLEY WITH REDUCTION GEAR FOR 28 Kg Max
6D6.6633 	CALOTTA IN NYLON LATO OPPOSTO PULEGGE Art. 6D5.3773 E 6A2.7702 E BIFORA NYLON CAP FOR OPPOSITE OF PULLEY
6A6.6813 	CALOTTA INSERITA NELLA PULEGGIA Art. 6A2.7702 CAP TO BE INSERTED IN THE PULLEY
6B4.4260 	RULLO ROLL
6D3.1829/30	CINTINO 20x1.2 STRAP
136-1123 	CERNIERA HINGE
NB. PER PORTATE DA 28 A 32 Kg UTILIZZARE MOVIMENTAZIONE CON ARGANELLO PER PORTATE SUPERIORI A 32 Kg UTILIZZARE MOVIMENTAZIONE ARGANELLO E MOLLA DI COMPENSAZIONE FOR WEIGHTS 28-32 Kg A GEAR HAS TO BE USED. FOR WEIGHTS OVER 32 Kg A GEAR WITH A COMPENSATION SPRING HAS TO BE USED.	