

MANUALE TECNICO SISTEMA EKU 78 TT

EDIZIONE 09/2016



TECHNICAL MANUAL EKU 78 TT SYSTEM

EDITION 09/2016

DESCRIZIONE TECNICA DEL SISTEMA PER SERRAMENTI A BATTENTE A TAGLIO TERMICO EKU 78 TT

Profilati estrusi in lega di alluminio EN AW-6060 (UNI EN 573-3)

Stato di fornitura: T5

Isolamento termico ottenuto tramite barrette in poliammide, inserite in apposite sedi tra i due profili in alluminio (guscio interno ed esterno) e successivamente bloccate mediante rullatura sulla parte esterna di alluminio.

Tolleranze dimensionali e spessori: UNI EN 12020-2

Lunghezza commerciale barre profilati: mm. 6500

I profilati a taglio termico della serie EKU 78 TT devono essere trattati superficialmente osservando i criteri previsti dalle direttive per l'ottenimento del marchio Qualanod, per l'anodizzazione e Qualicoat per la verniciatura; in ogni caso non dovrà essere superata la temperatura max di 190 °C per oltre 15 minuti, al fine di non pregiudicare le caratteristiche meccaniche e dimensionali della barretta in poliammide.

Caratteristiche principali del Sistema:

<i>Dimensione base:</i>	<i>- sezione del telaio fisso</i>	<i>mm. 78</i>
	<i>- sezione dell'anta</i>	<i>mm. 88</i>
	<i>- sovrapposizione a muro dei telai fissi</i>	<i>mm. 25</i>
	<i>- altezza sede vetro</i>	<i>mm. 22 / 25</i>
	<i>- larghezza massima per vetro o pannello</i>	<i>mm. 71</i>

inserimento del vetro con fermavetro a scatto;

sedi alloggiamento accessori: a dimensioni standard secondo camera europea mm. 14-18;

tenuta aria/acqua ottenuta tramite guarnizione centrale a giunto aperto, con guarnizione di tenuta parapolvere e antirumore inserita nella cava dell'aletta interna dell'anta;

possibilità d'impiego: i profilati consentono la costruzione di serramenti a superfici piane, complanari sul lato esterno e sormonto interno, con aletta di vetratura arrotondata e a vetro ad infilare; si possono fabbricare porte e finestre a battente, con apertura ad una o più ante, a wasistas, ad anta ribalta, monoblocco, vetrate fisse, vetrine per negozi, portoncini con apertura verso l'interno e/o esterno;

NOTE TECNICHE

Il peso dei profilati è quello teorico e potrà variare in funzione delle tolleranze dimensionali e di spessore previste dalla norma UNI EN 12020-2; le dimensioni di taglio indicate nelle apposite distinte inserite nel catalogo, sono calcolate in base alle dimensioni nominali: nella pratica potranno essere influenzate dalle tolleranze di estrusione, pertanto dovranno essere arrotondate secondo la precisione ed il tipo di impostazione delle misure nelle macchine impiegate. Gli schemi, le sezioni e gli attacchi a muro riportati sul catalogo, non hanno valore limitativo, ma solo di esemplificazione di alcune delle situazioni che più comunemente si trovano nella realtà e di soluzione consigliabile.

La posa del serramento va eseguita rispettando la normativa, le prescrizioni e le raccomandazioni specifiche esistenti in Italia.

I momenti di inerzia riportati sono teorici.

Il Sistema di profilati riportato in questo catalogo è brevettato; tutti i dati riportati nel presente catalogo sono indicativi e non impegnano la Profilati S.p.A. e la Trafileries Emiliane Sud S.p.A. che si riservano di apportare in qualsiasi momento quelle modifiche che riterranno opportune al fine di migliorare i prodotti.

Quanto illustrato nel presente catalogo è di esclusiva proprietà di Profilati S.p.A. e, a termine di legge, ne è vietata la riproduzione, anche parziale, se non esplicitamente autorizzata.

TECHNICAL DESCRIPTION OF THE EKU 78 TT SYSTEM FOR THERMAL BREAK WINDOWS AND DOORS

Aluminium alloy EN AW-6060 (UNI EN 573-3) extruded sections

Temper: T5

Thermal insulation obtained through polyamide bars, inserted in suitable seats between the two sides of the aluminium profiles and then locked by means of rolling on the external aluminium part.

Dimensional tolerances and thicknesses: UNI EN 12020-2

Commercial length of the bars: 6500 mm

The thermal break sections of the system EKU 78 TT have to be treated on the surface in compliance with the criteria set forth by the Qualanod Mark directives for anodizing and Qualicoat for varnishing.

The max. 190 °C temperature shall not be exceeded in any case for more than 15 minutes, in order not to jeopardize the mechanical and dimensional characteristics of the polyamide bars.

Main characteristics of the system:

<i>Basic dimensions:</i>	<i>- fixed frame cross-section</i>	<i>mm. 78</i>
	<i>- wing cross-section</i>	<i>mm. 88</i>
	<i>- fin of rabbet for fixed frames</i>	<i>mm. 25</i>
	<i>- glass seat space</i>	<i>mm. 22 / 25</i>
	<i>- maximum width for glass or panel</i>	<i>mm. 71</i>

Glass insertion with snap connection glazing bead;

Accessory housing seats: standard dimensions according to the 14-18 mm European air space;

Sealing obtained through central open joint gasket with weather strip inserted in the slot on the internal fin of the wing;

Application: the system allows for construction of plane surface fixtures, coplanar on the external side and the internal overlap, with rounded glass beading. It is possible to manufacture door and casement, or top-hung, one or more wing opening windows, fixed glazing panels, shop-windows, internal and/or external opening doors. The latter have an external/internal coplanar surface.

TECHNICAL NOTES

The weight of the sections is theoretical and can vary according to the dimensional and thickness tolerances specified by UNI EN 12020-2 standard; The cutting dimension indicated in the appropriate forms are calculated on the basis of the nominal size. In practice these dimensions can be affected by extrusion tolerances; therefore they shall be rounded according to accuracy and type of measures set in the machines used. Diagrams, sections and wall situations which are most commonly found in practice and recommended solutions. Fixture mounting shall be in compliance with standards, requirements and specific recommendations existing in Italy.

The moments of inertia shown are theoretical.

The system of sections shown in this catalogue is patented; all data given in this catalogue are an indication and do not bind Profilati S.p.A. and Trafilerie Emiliane Sud S.p.A. which reserve the right to make any modifications deemed appropriate to improve products.

All that is shown in this catalogue is property of Profilati S.p.A. Any reproduction, even if partial, is forbidden by law unless expressly authorized

DILATAZIONE TERMICA LINEARE

Qualunque corpo solido di qualsivoglia materiale, sottoposto ad una variazione di temperatura subisce una variazione di volume. Un aumento della temperatura del corpo solido comporta un corrispondente incremento di volume e viceversa una riduzione della temperatura genera un decremento di volume.

Normalmente le suddette variazioni di volume avvengono isotropicamente, ovvero il corpo solido subisce la stessa variazione percentuale di volume nelle tre dimensioni dello spazio.

Esistono comunque moltissimi casi in cui una dimensione del corpo solido prevale in maniera così evidente sulle rimanenti da rendere trascurabili, su queste ultime, gli effetti delle deformazioni conseguenti a variazioni della temperatura. Questo è proprio il caso dei profili estrusi in alluminio dove la lunghezza del profilato è notevolmente superiore alle dimensioni della sezione ortogonale alla lunghezza stessa.

In tal caso si può parlare di **dilatazione termica lineare**.

Il coefficiente di dilatazione termica lineare, indicato con il simbolo λ , in prima approssimazione può essere considerato una costante dipendente dal materiale ed esprime la variazione di lunghezza subita da una barra di un metro in seguito ad una variazione di temperatura di un grado centigrado.

L'entità della deformazione subita viene calcolata confrontando le dimensioni spaziali del corpo prima e dopo la variazione della temperatura.

L'allungamento ΔL è proporzionale all'aumento di temperatura ed alla lunghezza iniziale della barra e si calcola con la seguente equazione:

$$\Delta L = L_t - L_o = \lambda L_o (t - t_o)$$

ovvero:

$$L_t = L_o + \lambda L_o (t - t_o) = L_o [1 + \lambda (t - t_o)]$$

dove:

t_o = temperatura iniziale ;

t = temperatura finale ;

L_t = lunghezza alla temperatura t ;

L_o = lunghezza alla temperatura t_o ;

λ = coefficiente di dilatazione termica (vedi tabella seguente) ;

Tabella coefficienti di dilatazione lineare: la tabella indica per alcuni tipi di materiale, in rapporto al proprio coefficiente di dilatazione lineare, di quanti mm si allunga una sbarra lunga 1 metro in seguito all'aumento di 1°C di temperatura.

Materiale	$\lambda (^{\circ}\text{C}^{-1})$	Allungamento per aumento di 1°C per 1m di lunghezza (mm)
Acciaio	$11 * 10^{-6}$	0,011
Alluminio	$24 * 10^{-6}$	0,024
Ferro	$12 * 10^{-6}$	0,012
P.V.C.	$70 * 10^{-6}$	0,070
Vetro	$9 * 10^{-6}$	0,009

DISTORSIONE TERMICA

I serramenti e le facciate continue tra le varie funzioni hanno anche quella, ben nota per il risparmio energetico, di separare ambienti aventi condizioni climatiche differenti. I profili estrusi in alluminio, siano essi a taglio termico o meno, sono quindi sottoposti a variazioni termiche notevoli. Queste variazioni sono particolarmente elevate nel periodo estivo quando la superficie esterna dei profilati è soggetta ad una elevata esposizione solare che, per il fenomeno dell'irraggiamento, genera un incremento di temperatura superficiale.

A causa di questo maggiore riscaldamento la parte esterna del profilo si dilata maggiormente rispetto a quella interna, generando una inflessione della barra, con estradosso rivolto verso l'esterno, che aumenta all'aumentare della differenza di temperatura tra le due superfici interna ed esterna del profilo stesso.

La situazione è illustrata nelle figure 1 e 2 dove il profilo è appoggiato alle estremità, è sottoposto ad una variazione termica lineare ΔT tra la superficie esterna, a temperatura T_2 esposta all'irraggiamento solare, e quella interna non esposta, a temperatura $T_1 < T_2$, e, a causa delle tensioni generate, subisce una inflessione con estradosso rivolto verso la superficie con temperatura più elevata.

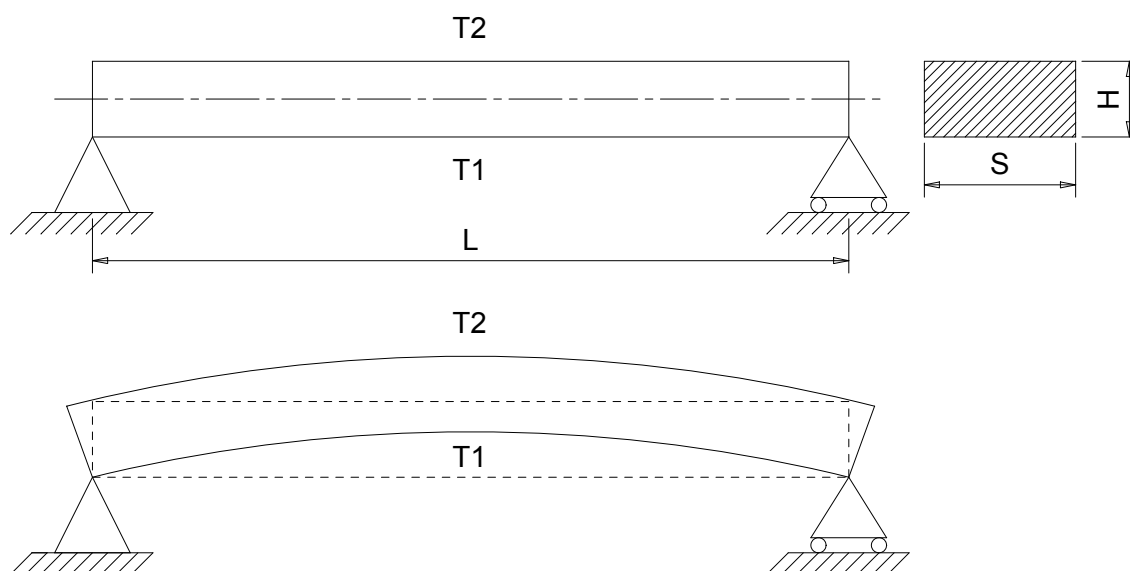

Questo fenomeno, particolarmente visibile nelle aperture a nei profilati molto lunghi, è noto come **distorsione termica**, e questa deformazione, nei casi peggiori e durante le ore di maggiore irraggiamento solare, può causare difficoltà di apertura e chiusura di finestre e porte o generare altri tipi di malfunzionamento.

Il presente documento è da considerarsi di natura informativa ed ha l'unico scopo di informare i nostri clienti del fenomeno sopra descritto. La distorsione termica è sempre presente, in misura maggiore o minore, e non è completamente risolvibile con i materiali e le tecnologie attualmente disponibili per la costruzione di profilati per il settore edilizio.

La distorsione termica è ancor più evidente nei profili dotati di taglio termico che sono dotati di maggiori capacità isolanti e di conseguenza portano ad una maggiore differenza di temperatura tra le superfici interna ed esterna.

Esistono comunque alcune semplici procedure che, quando applicabili, possono considerevolmente ridurre gli effetti della deformazione termica:

- 1) la riduzione dell'esposizione diretta ai raggi solari
- 2) la riduzione della dimensione S della superficie esposta del profilo
- 3) l'utilizzo di finiture chiare del profilo
- 4) la riduzione della lunghezza L del profilo
- 5) l'utilizzo di profili aventi sezione di altezza H maggiore lungo il flusso di calore

Per ogni altra informazione o consulenza sulla correttezza di utilizzo dei profili, preghiamo di contattare l'Ufficio Tecnico di Profilati S.p.A.

THERMAL LINEAR EXPANSION

Every solid body, irrespective of the material, when exposed to temperature variations, undergoes a change in volume. An increase in temperature of the solid body means a corresponding increase in volume, whereas a decrease in temperature creates a reduction in volume.

Normally, the variations in volume are uniformly distributed, in other words the solid body has an equal change of volume in all three dimensions.

However, many cases exist where one dimension of the solid body is particularly affected thus rendering the deformations caused by temperature variations of the other dimensions almost negligible. This is exactly the case with extruded aluminium profiles where the length of the profiles is much greater compared to the orthogonal section of the same profile. In this situation, the change in volume is referred to as **thermal linear expansion**

The coefficient of thermal linear expansion, indicated by the symbol λ , in general terms, can be considered a constant that depends on the material and represents the variation in length of a bar of one metre having undergone a temperature change of one degree.

The size of the deformation is calculated by comparing the dimensions of the bar before and after the temperature variation.

The increase in length ΔL is proportional to the increase in temperature and the initial length of the bar, it is calculated by using the following equation:

$$\Delta L = L_t - L_o = \lambda L_o (t - t_o)$$

or:

$$L_t = L_o + \lambda L_o (t - t_o) = L_o [1 + \lambda (t - t_o)]$$

where:

t_o = initial temperature ;

t = final temperature ;

L_t = length at temperature t ;

L_o = length at temperature t_o ;

λ = coefficient of thermal expansion (see following table) ;

The table below indicates for five materials the coefficient of thermal linear expansion, how many millimetres a one metre length bar expands having undergone a temperature increase of one degree.

Material	$\lambda (^{\circ}\text{C}^{-1})$	Material length increase, 1 degree per 1m (mm)
Steel	$11 * 10^{-6}$	0,011
Aluminium	$24 * 10^{-6}$	0,024
Iron	$12 * 10^{-6}$	0,012
P.V.C.	$70 * 10^{-6}$	0,070
Glass	$9 * 10^{-6}$	0,009

THERMAL DISTORTION

Window and door frames as well as curtain walling, among their many functions, well known for their energy-saving properties, to separate completely different environmental conditions. Extruded aluminium profiles that are used for window and door frames, either thermal break or not, are therefore exposed to large thermal variations. These variations are normally particularly extreme in the summer period, when the surface of the frames is subjected to strong sunlight that causes a substantial increase in temperature.

As a consequence of this heating, the surface exposed to the sun expands more compared to the side not exposed, thus causing an inflexion of the bar outward towards the external exposed surface, that increase with the difference of temperature between the internal and external surfaces of the profile.

The situation is illustrated in figure 1, where the profile is anchored at the ends, undergoes a temperature variation ΔT between the external exposed surface, at temperature T_2 , and the internal non-exposed surface, at temperature $T_1 < T_2$, and, because of the stress generated, an inflexion of the bar is caused, outward towards the more higher temperature surface.

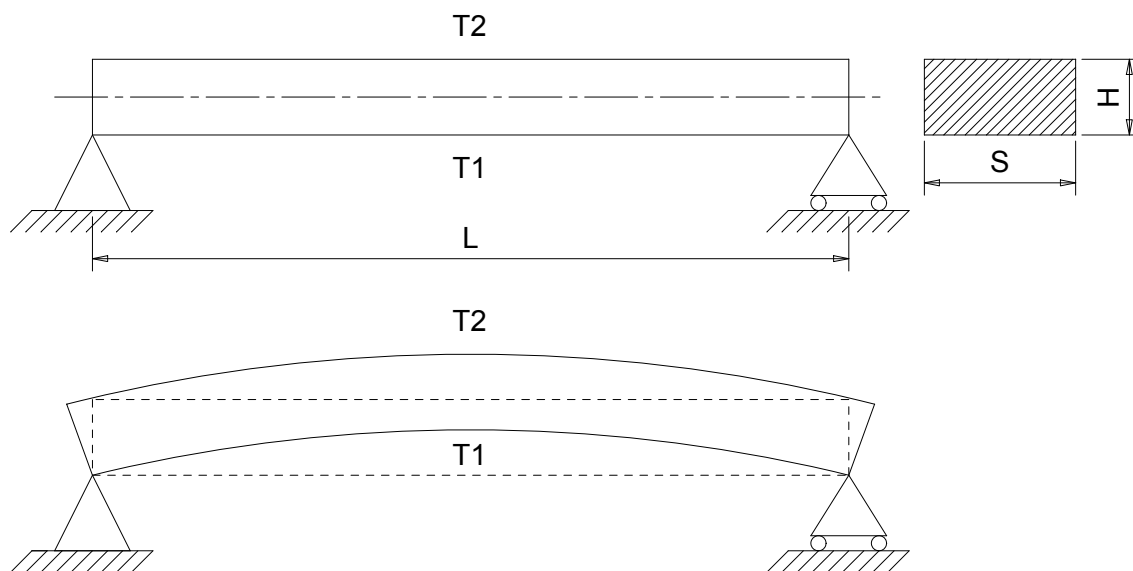









This phenomenon, which is particularly visible on wing-opening and on very long transom, is known as **thermal distortion** and is the deformation that, in the worst cases and during the hours of max sunlight, can cause difficulty in opening and closing windows and doors or generate other types of malfunctioning.

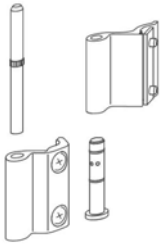
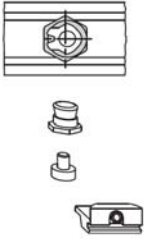
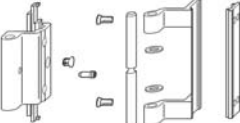



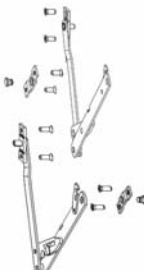

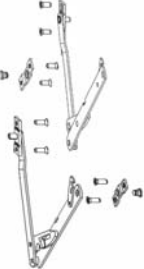
The present document is intended to be only informative and has the purpose to inform all of our clients of the phenomenon described herein. The thermal distortion is always present, to a greater or lesser degree, and is not completely resolvable with the materials and technology currently available for the construction of profiles in the building sector. The thermal distortion is even more evident in thermal break profiles as they have a larger insulating capacity, and as a consequence a greater difference in temperature between the exposed and non-exposed surfaces. Nevertheless, there are some simple procedures, where it is possible to apply them, that can considerably reduce the effects of the thermal distortion:

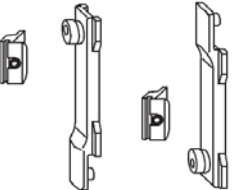

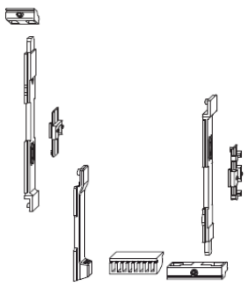
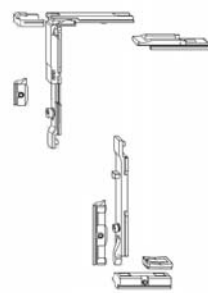
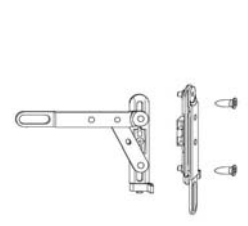
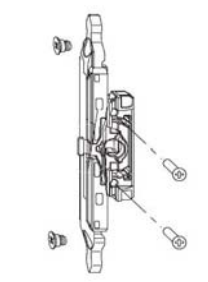

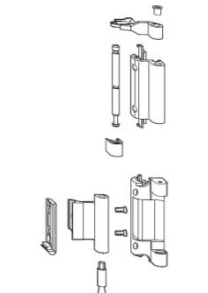
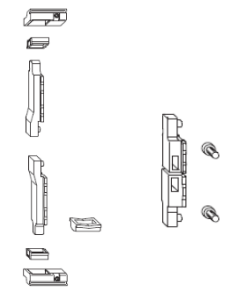
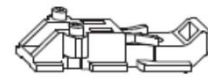

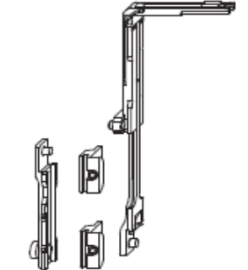
- 1) the reduction of the exposure to direct sunlight
- 2) the reduction in size S of the exposed surfaces of the profile
- 3) the use of light colour finishing on the profile
- 4) the reduction of the length L of the profile
- 5) the use of a higher profile width H where there is the heat flow



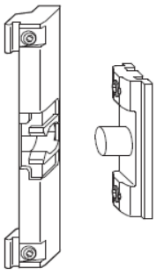
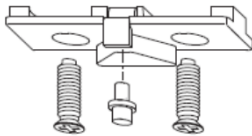
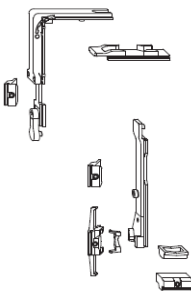

For any further information or advice on the correctness of specific building systems, please contact the Technical Office of Profilati S.p.A.

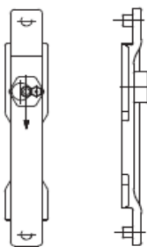
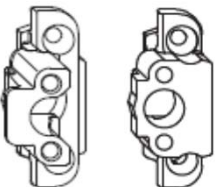
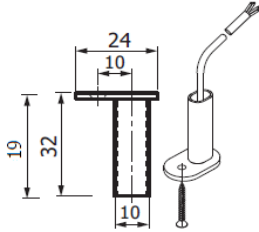
Accessori / Accessory

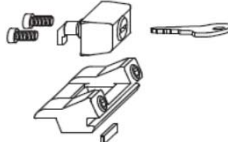

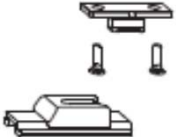

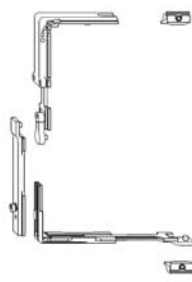
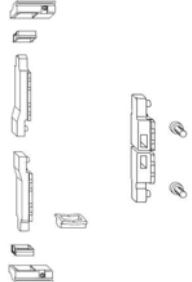
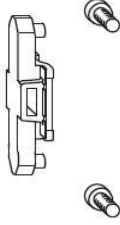
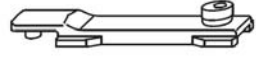
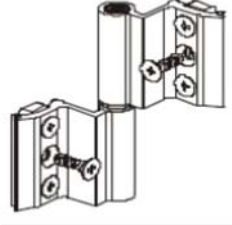
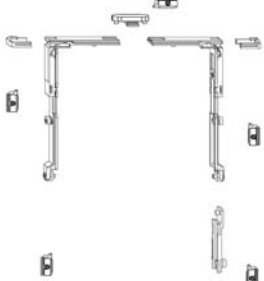

	<p>art. EA-0001.. *</p> <p>cerniera ad infilare per telai a sormonto portata: kg . 80 con due cerniere</p> <p>hinge fitted to the overlapping frame capacity: kg. 80 with two hinges</p>		<p>art. EA-0008</p> <p>kit di chiusura supplementare registrabile</p> <p>additional adjustable fastening kit</p>
	<p>art. EA-0002.. *</p> <p>cerniera a pettine per telai a sormonto - portata: kg . 80/100 con due cerniere</p> <p>Two-handed comb hinge for overlapping frame - capacity: kg. 80/100 with two hinges</p>		<p>art. EA-0009</p> <p>chiusura intermedia supplementare</p> <p>intermediate additional closing</p>
	<p>art. EA-0003.. *</p> <p>cremonese "Globe" aperture ad anta semplice rotazione 90°</p> <p>"Globe" cremone for casement window 90° rotation</p>		<p>art. EA-0010</p> <p>braccio vasistas orizzontale per larghezze anta superiori a 920 mm. applicare 2 bracci</p> <p>horizontal vasistas arm Apply two arms in case of wing width over 920mm</p>
	<p>art. EA-0004.. *</p> <p>cremonese "Globe" aperture ad anta semplice ed anta ribalta rotazione 180°</p> <p>"Globe" cremone for tilt and turn opening and casement window 180° rotation</p>		<p>art. EA-0011</p> <p>braccio di sicurezza per vasistas per altezza ante da 350 a 600 mm. da abbinare con articolo EA-0006</p> <p>vasistas safety arm for wing height 350 to 600 mm. to combine with item EA-0006</p>
	<p>art. EA-0006</p> <p>piastrina di spessoramento per articolo EA-0011 ed EA-0012</p> <p>shim plate for item EA-0011 and EA-0012</p>		<p>art. EA-0012</p> <p>braccio di sicurezza per vasistas per altezza ante da 601 a 1200 mm. da abbinare con articolo EA-0006</p> <p>vasistas safety arm for wing height 601 to 1200 mm. to combine with item EA-0006</p>
	<p>art. EA-0007</p> <p>rosto di chiusura supplementare</p> <p>additional closing element</p>		<p>art. EA-0013</p> <p>kit chiusure per anta semplice e vasistas</p> <p>casement window and vasistas closing kit</p>

Accessori / Accessory			
	<p>art. EA-0014</p> <p>kit chiusura anta secondaria</p> <p>combined wing closing kit</p>		<p>art. EA-0020</p> <p>kit base anta ribalta</p> <p>Tilt and turn mechanism</p>
	<p>art. EA-0015</p> <p>leva di comando per articolo EA-0014</p> <p>lever movement for item EA-0014</p>		<p>art. EA-0021</p> <p>movimentazione interna per martellina quadro 7 mm. con dispositivo anti falsa manovra</p> <p>internal device for handle (square connection 7 mm.) with anti false manoeuvre</p>
	<p>art. EA-0016</p> <p>kit aggiuntivo per portate di 130 kg. da abbinare con EA-0022</p> <p>additional kit for maximum sash weight 130 kg. to combine with EA-0022</p>		<p>art. EA-0022.. *</p> <p>confezione cerniere anta abbinata ed anta/ribalta portata 100/130 kg</p> <p>kit hinges for tilt and turn and combined window capacity: kg. 100/130</p>
	<p>art. EA-0017</p> <p>kit chiusure anta semplice con puntali in PVC</p> <p>casement window closing kit with PVC terminal</p>		<p>art. EA-0023</p> <p>braccio cerniera anta abbinata (con EA-0022)</p> <p>arm hinge combined wing (with EA-0022)</p>
	<p>art. EA-0018.. *</p> <p>martellina "Globe" (quadro 7 mm.)</p> <p>"Globe" handle (square connection 7 mm.)</p>		<p>art. EA-0024</p> <p>braccio anta ribalta per ante da 355 a 600 mm.</p> <p>tilt and turn arm for wing from 355 to 600 mm.</p>
	<p>art. EA-0019</p> <p>chiusura supplementare verticale ed orizzontale</p> <p>horizontal and vertical additional closing</p>		<p>art. EA-0025</p> <p>braccio anta ribalta per ante da 601 a 1250 mm.</p> <p>tilt and turn arm for wing from 601 to 1250 mm.</p>

Accessori / Accessory			
	<p>art. EA-0026</p> <p>braccio supplementare anta ribalta per ante da 1251 a 1600 mm.</p> <p>Additional arm tilt and turn wing for wing from 1251 to 1600 mm.</p>		<p>art. EA-0045.. *</p> <p>cremonese "Globe" aperture ad anta semplice ed anta ribalta rotazione 180° con chiave</p> <p>"Globe" lockable cremonese for tilt and turn opening and casement window 180° rotation</p>
	<p>art. EA-0027</p> <p>dispositivo ferma anta</p> <p>wing stop device</p>		<p>art. EA-0046</p> <p>dispositivo per micro ventilazione</p> <p>micro-ventilation device</p>
	<p>art. EA-0041</p> <p>kit base anta ribalta TBT "logica"</p> <p>Tilt and turn mechanism TBT "logic"</p>		<p>art. EA-0047</p> <p>adattatore foro astina da 8 a 6 mm.</p> <p>rod hole adapter from 8 to 6 mm.</p>
	<p>art. EA-0042.. *</p> <p>martellina "Globe RR"</p> <p>"Globe RR" handle</p>		<p>art. EA-0048</p> <p>collegamento "Aerocontrol"</p> <p>"Aerocontrol" connection</p>
	<p>art. EA-0043</p> <p>movimentazione interna per martelline art. EA-0042 e EA-0044</p> <p>internal device for handle item EA-0042 and EA-0044</p>		<p>art. EA-0049</p> <p>sensore magnetico "Aerocontrol" con cavo da 6 mt.</p> <p>"Aerocontrol" magnetic sensor with 6mt. wire</p>
	<p>art. EA-0044.. *</p> <p>martellina con chiave "Globe RR"</p> <p>"Globe RR" lockable handle</p>		<p>art. EA-0050..*</p> <p>serratura</p> <p>lock</p>

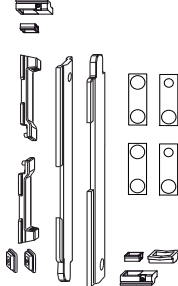
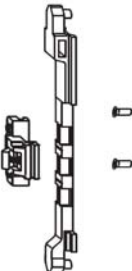
Accessori / Accessory			
	<p>art. EA-0051 kit chiusura antieffrazione tamper-proof closing kit</p>		<p>art. EA-0056 sostegno cremonese cremone support</p>
	<p>art. EA-0052 registrazione laterale cerniere hinges lateral adjusting</p>		<p>art. EA-0057 blocco rotazione cremonese a 90° rotation lock cremone to 90°</p>
	<p>art. EA-0053 kit chiusure multipunto per anta semplice casement window multipoint closing kit</p>		<p>art. EA-0058 kit chiusure per infisso a due ante semplici two wings casement window closing kit</p>
	<p>art. EA-0054 cursore di collegamento cremonese con rotazione 180° connection device for cremone 180° rotation</p>		<p>art. EA-0059 terminale asta con nottolino rod terminal with locking pawl</p>
	<p>art. EA-0055.. * cerniera ad infilare per 3a anta 3rd wing fitted hinge</p>		<p>art. EA-0060 kit chiusura vasistas vasistas closing kit</p>
<p>* Colori standard: art. EA-.....BI ---> bianco RAL 9016 art. EA-.....AR ---> argento RAL 9006 art. EA-.....NE ---> nero RAL 9005</p>		<p>* Standard colours: art. EA-.....BI ---> white RAL 9016 art. EA-.....AR ---> silver RAL 9007 art. EA-.....NE ---> black RAL 9006</p>	





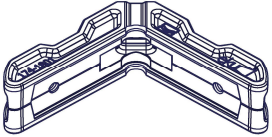
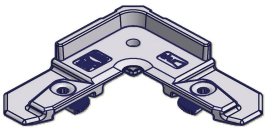
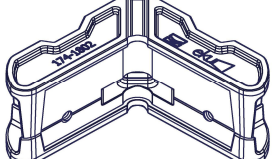
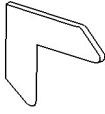
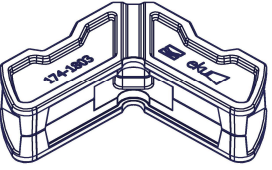
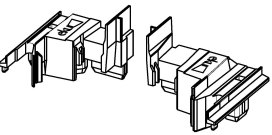
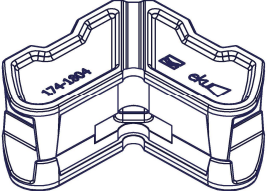
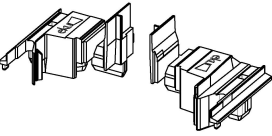
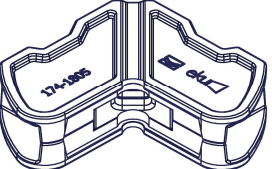
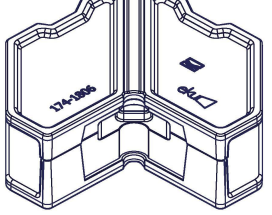

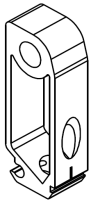
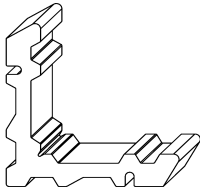
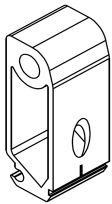
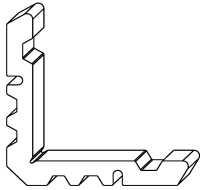
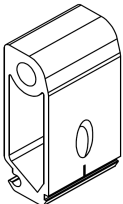
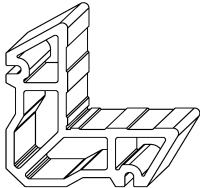
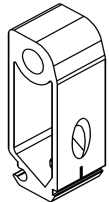
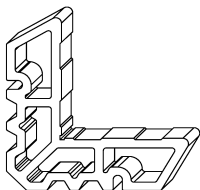
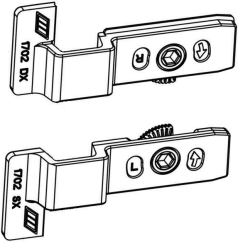
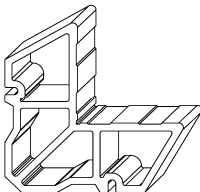
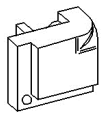
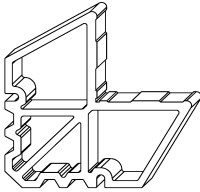
Accessori / Accessory



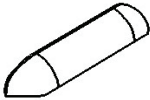
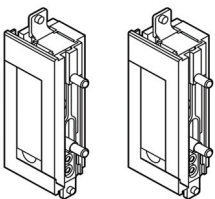
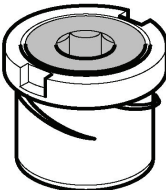
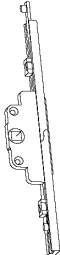

	<p>art. EA-0061</p> <p>braccio supplementare vasistas</p> <p>Additional arm vasistas wing</p>		<p>art. EA-0324</p> <p>supporto invito per anta EA-0323</p> <p>support for wing guide head</p>
	<p>art. EA-0106</p> <p>chiusura supplementare per TBT "logica"</p> <p>TBT "logic" additional closing</p>		<p>art. EA-0329</p> <p>doppio catenacciolo universale</p> <p>multipurpose double latch</p>
	<p>art. EA-0160</p> <p>kit anti falsa manovra per cremonese EA-0004 (sostituisce EA-0005)</p> <p>kit anti false manoeuvres for cremone EA-0004 (replace EA-0005)</p>		
	<p>art. EA-0111</p> <p>braccio corto frizionato limitatore di apertura</p> <p>short limit stay with brake</p>		
	<p>art. EA-0112</p> <p>braccio lungo frizionato limitatore di apertura</p> <p>long limit stay with brake</p>		
	<p>art. EA-0323</p> <p>invito per anta in PVC</p> <p>PVC wing guide head</p>		

Accessori / Accessory			
	<p>art. 174-1801</p> <p>Squadretta interna a cianfrinare telai piccoli</p> <p>Internal corner joint locked by crimping for small fixed frames</p>		<p>art. 174-1591</p> <p>Squadretta allineamento esterna</p> <p>External alignment corner joint</p>
	<p>art. 174-1802</p> <p>Squadretta interna a cianfrinare ante piccole</p> <p>Internal corner joint locked by crimping for small wings</p>		<p>art. 153-040.4</p> <p>Squadretta allineamento</p> <p>Alignment corner joint</p>
	<p>art. 174-1803</p> <p>Squadretta interna a cianfrinare telai medi</p> <p>Internal corner joint locked by crimping for medium fixed frames</p>		<p>art. EA-0039</p> <p>Tappi di tenuta a giunto aperto per profilo di riporto TT78-19</p> <p>Seal plug for central rabbet TT78-19</p>
	<p>art. 174-1804</p> <p>Squadretta interna a cianfrinare ante medie</p> <p>Internal corner joint locked by crimping for medium wings</p>		<p>art. EA-0040</p> <p>Tappi di tenuta a giunto aperto per profilo di riporto TT78-25</p> <p>Seal plug for central rabbet TT78-25</p>
	<p>art. 174-1805</p> <p>Squadretta interna a cianfrinare telai maggiorati</p> <p>Internal corner joint locked by crimping for oversize fixed frames</p>		
	<p>art. 174-1806</p> <p>Squadretta interna a cianfrinare ante maggiorate</p> <p>Internal corner joint locked by crimping for oversize wings</p>		

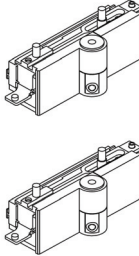
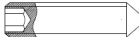
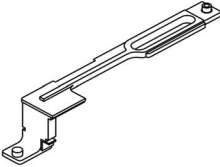

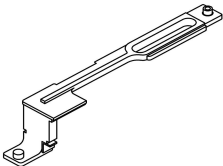

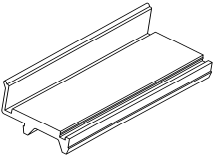
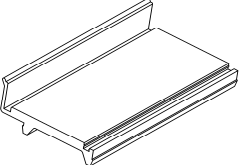

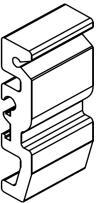
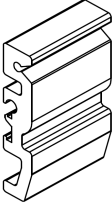

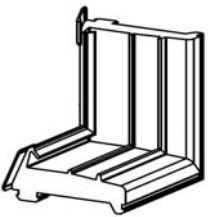

Accessori / Accessory			
	<p>art. EA-0133</p> <p>Cavallotto interno per telai piccoli</p> <p>Internal "T" joint for small fixed frames</p>		<p>art. 153-0057</p> <p>Squadretta esterna a cianfrinare telai piccoli</p> <p>External corner joint locked by crimping for small fixed frames</p>
	<p>art. EA-0134</p> <p>Cavallotto interno per telai medi</p> <p>Internal "T" joint for medium fixed frames</p>		<p>art. 153-0058</p> <p>Squadretta esterna a cianfrinare ante piccole</p> <p>External corner joint locked by crimping for small wings</p>
	<p>art. EA-0135</p> <p>Cavallotto interno per telai maggiorati</p> <p>Internal "T" joint for oversize fixed frames</p>		<p>art. 153-0059</p> <p>Squadretta esterna a cianfrinare telai medi</p> <p>External corner joint locked by crimping for medium fixed frames</p>
	<p>art. EA-0136</p> <p>Cavallotto interno per ante</p> <p>Internal "T" joint for wings</p>		<p>art. 153-0060</p> <p>Squadretta esterna a cianfrinare ante medie</p> <p>External corner joint locked by crimping for medium wings</p>
	<p>art. EA-0032</p> <p>Coppia cavallotti esterni per ante sagomate / stondate</p> <p>Pair external "T" joints for shaped / rounded wings</p>		<p>art. 153-0061</p> <p>Squadretta esterna a cianfrinare telai maggiorati</p> <p>External corner joint locked by crimping for oversize fixed frames</p>
	<p>art. 142-2224 164-2224</p> <p>Angolo in zama per fermavetro arrotondato</p> <p>Zamak angle for rounded glass beading</p>		<p>art. 153-0062</p> <p>Squadretta esterna a cianfrinare ante maggiorate</p> <p>External corner joint locked by crimping for oversize wings</p>

Accessori / Accessory

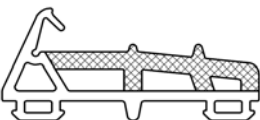
	<p>art. 142-2145</p> <p>Cappetta copri asola di drenaggio acqua</p> <p>Cover cup for drainage water buttonhole</p>		<p>art. EA-0033</p> <p>Coppia frizioni per bilico</p> <p>Friction joint for pivot</p>
	<p>art. 104-600.01</p> <p>Rapid block Z/P</p> <p>Rapid block Z/P</p>		<p>art. EA-0034</p> <p>Movimentazione per aperture bilico</p> <p>Mill-in gear</p>
	<p>art. 104-RB640</p> <p>Spessore per corpo Z/P per telai piccoli</p> <p>Z/P body shim for small fixed frames</p>		<p>art. EA-0035</p> <p>Incontro registrabile</p> <p>Adjustable locking plate</p>
	<p>art. 104-RB660</p> <p>Spessore per corpo Z/P per telai medi</p> <p>Z/P body shim for medium fixed frames</p>		<p>art. EA-0036</p> <p>Incontro</p> <p>Locking plate</p>
	<p>art. 104-RB663</p> <p>Spessore per corpo Z/P per telai maggiorati</p> <p>Z/P body shim for oversize fixed frames</p>		<p>art. EA-0037</p> <p>Coppia frizioni per bilico verticale</p> <p>Vertical friction joint for pivot</p>
	<p>art. 535-090.19</p> <p>Grano cava esagonale M4 x 8 INOX A2 per squadrette ad avvitare</p> <p>Hexagon socket set screw M4 x 8 INOX A2 for aluminium screwde bracket</p>		<p>art. EA-0063</p> <p>Asta di trazione bilici verticali SX</p> <p>Vertical pivot traction rod Left</p>

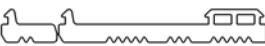
Accessori / Accessory			
	<p>art. EA-0064</p> <p>Asta di trazione bilici verticali DX</p> <p>Vertical pivot traction rod Right</p>		<p>art. EA-0143</p> <p>Spina in zama 3,3 x 8</p> <p>3,3 x 8 zamak pin</p>
	<p>art. EA-0067</p> <p>Tassello vetro per telai</p> <p>Frame glass support</p>		
	<p>art. EA-0068</p> <p>Tassello vetro per ante</p> <p>Wing glass support</p>		
	<p>art. EA-0137</p> <p>Cavallotto esterno per telai piccoli Utilizzare spina Art. EA-0143</p> <p>External "T" joint for small fixed frames Use pin Art. EA-0143</p>		
	<p>art. EA-0138</p> <p>Cavallotto esterno per telai medi Utilizzare spina Art. EA-0143</p> <p>External "T" joint for medium fixed frames Use pin Art. EA-0143</p>		
	<p>art. EA-0139</p> <p>Cavallotto esterno per telai maggiorati Utilizzare spina Art. EA-0143</p> <p>External "T" joint for oversize fixed frames Use pin Art. EA-0143</p>		

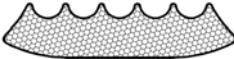
Guarnizioni / Gaskets

	<p>art. 126-2194</p> <p>Guarnizione di vetragezione interna spessore 3/4 mm</p> <p>Mm 3/4 thick internal glass beading</p>		<p>art. 126-20157</p> <p>Guarnizione di vetragezione interna spessore 6/7 mm</p> <p>Mm 6/7 thick internal glass beading gasket</p>
	<p>art. 126-2195</p> <p>Guarnizione di vetragezione interna spessore 5/6 mm</p> <p>Mm 5/6 thick internal glass beading</p>		<p>art. EG-0001</p> <p>Angolo vulcanizzato per pinna centrale art. EG-0002</p> <p>Vulcanized angle for gasket art. EG-0002</p>
	<p>art. 126-2197</p> <p>Guarnizione di vetragezione interna spessore 7/8 mm</p> <p>Mm 7/8 thick internal glass beading</p>		<p>art. EG-0002</p> <p>Guarnizione di tenuta centrale a giunto aperto</p> <p>Open joint central seal</p>
	<p>art. 126-2355</p> <p>Guarnizione di battuta interna</p> <p>Internal rabbet gasket</p>		<p>art. EG-0003</p> <p>Guarnizione di isolamento telaio/muro</p> <p>Frame/wall insulation gasket</p>
	<p>art. 126-2800</p> <p>Guarnizione di vetragezione interna spessore 2 mm.</p> <p>Mm 2 thick internal glass beading</p>		<p>art. EG-0023</p> <p>Inserto isolante sottovetro</p> <p>Insulating insert under glass</p>
	<p>art. EG-0069</p> <p>Guarnizione di vetragezione esterna spessore 4 mm.</p> <p>Mm 4 thick external glass beading</p>		<p>art. EG-0024</p> <p>Inserto isolante tra barrette</p> <p>Insulating insert between polyamide bars</p>

Guarnizioni / Gaskets

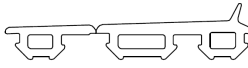
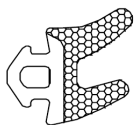
	<p>art. EG-0060</p> <p>Guarnizione di tenuta per bilico</p> <p>Seal gasket for pivot</p>		
	<p>art. EG-0061</p> <p>Guarnizione di battuta interna</p> <p>Internal rabbet gasket</p>		

Attrezzature / Equipement

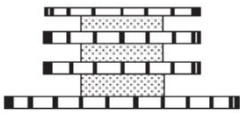
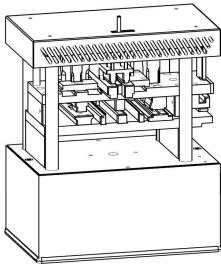
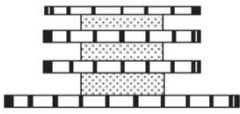
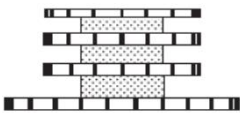
	<p>art. EU-0004</p> <p>Gruppo frese per telai fissi</p> <p>Milling cutter for fixed frames</p>		<p>art. EP-0001</p> <p>Punzonatrice</p> <p>Punching machine</p>
	<p>art. EU-0005</p> <p>Gruppo frese per ante apribili</p> <p>Milling cutter for wings</p>		<p>art. EP-0002</p> <p>Kit per cremonese</p> <p>Kit for cremone</p>
	<p>art. EU-0006</p> <p>Gruppo frese per ante apribili stondate</p> <p>Milling cutter for rounded wings</p>		

Layout accessori - Accessories Layout

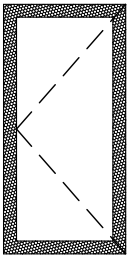

Schema accessori anta portata Kg 80
One wing scheme accessories capacity Kg 80

Campo di impiego finestra:
LA >300<1000 HA >400<2000
Campo di impiego portafinestra:
LA >300<1000 HA >400<2000

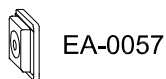
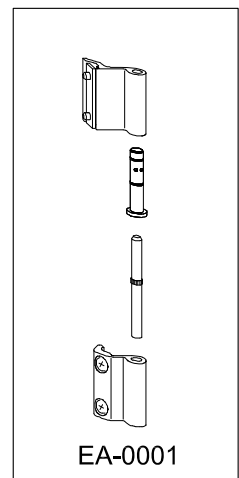
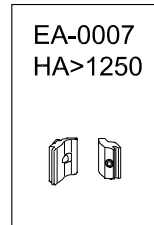
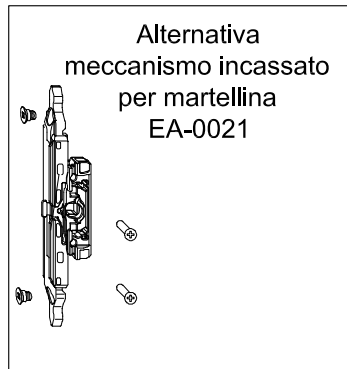
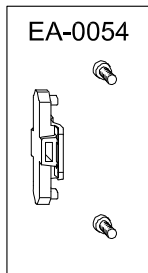
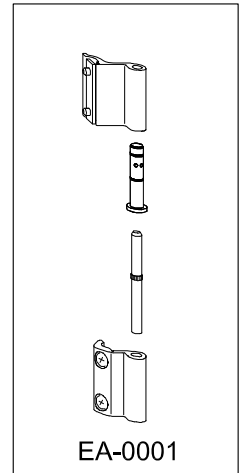
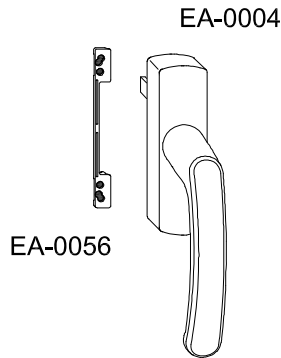
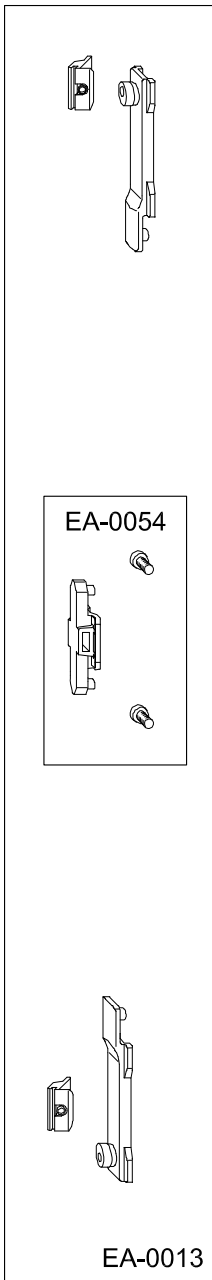

Layout accessori - Accessories Layout

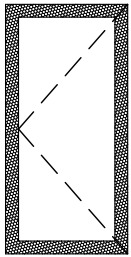

Schema accessori anta portata Kg 100/130

One wing scheme accessories capacity Kg 100/130

Campo di impiego finestra:
LA >355<1600 HA >500<2000
Campo di impiego portafinestra:
LA >355<1300 HA >500<2400

EA-0023

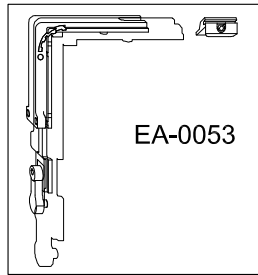
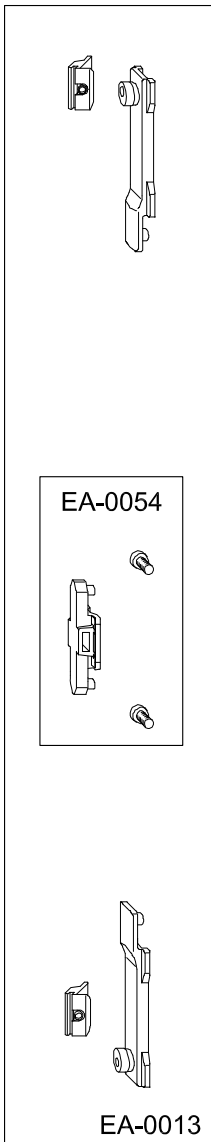
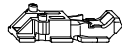

EA-0053

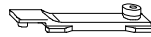

EA-0059

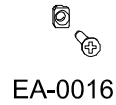

EA-0016

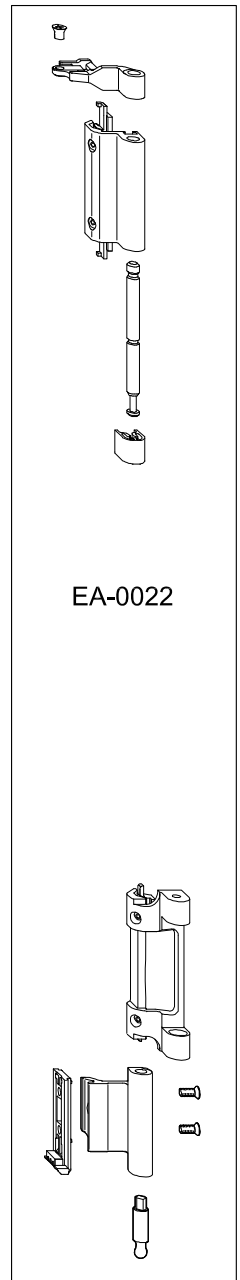

EA-0022

EA-0007
HA >1250

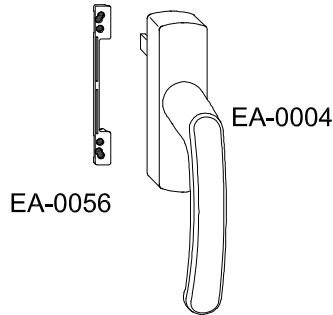

EA-0004

EA-0056

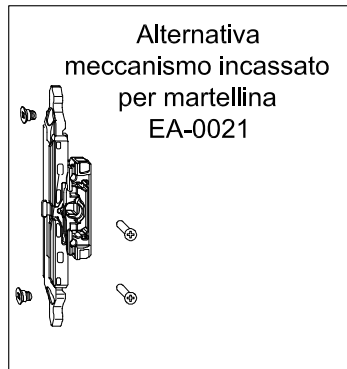

Alternativa
meccanismo
per martellina
EA-0021

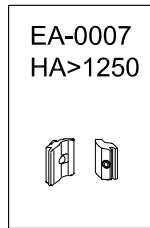

EA-0007
HA >1250

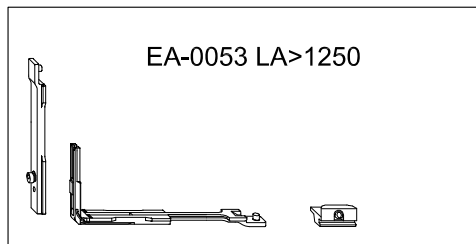

EA-0053 LA >1250



EA-0059

EA-0052

Layout accessori - Accessories Layout

Schema accessori anta ribalta portata Kg 100/130

One wing Tilt-Turn scheme accessories capacity Kg 100/130

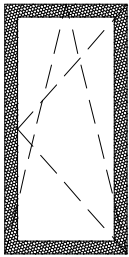

EA-0024 LA>355<600
EA-0025 LA>601<1250
EA-0026 LA>1251<1600

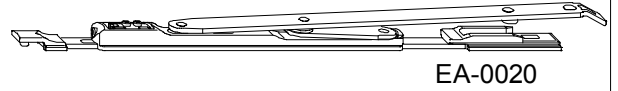
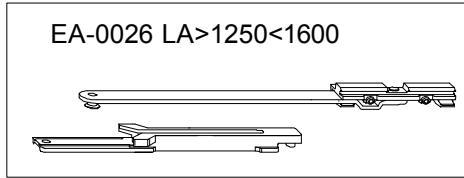

EA-0020

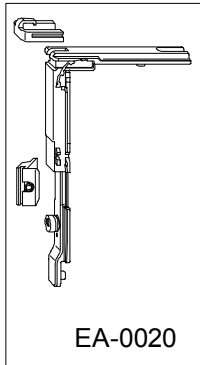

EA-0020

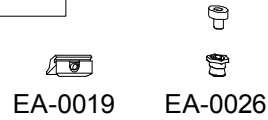

EA-0019

EA-0026

EA-0004

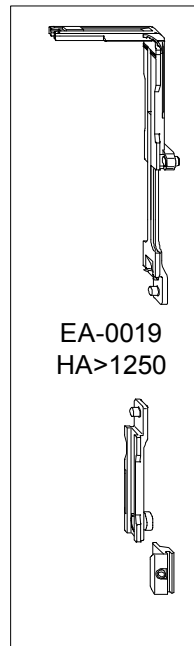
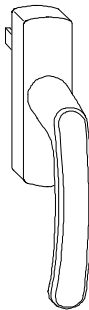

EA-0019
HA>1250

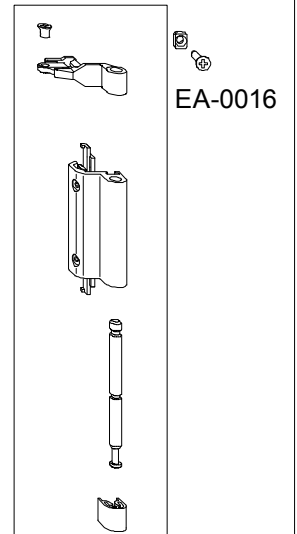

EA-0016

EA-0019

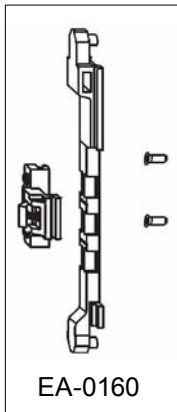

EA-0160

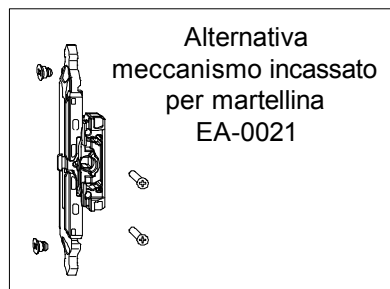

Alternativa
meccanismo incassato
per martellina
EA-0021

EA-0022

Campo di impiego finestra:
LA >355<1600 HA >500<2000
Campo di impiego portafinestra:
LA >355<1300 HA >500<2400

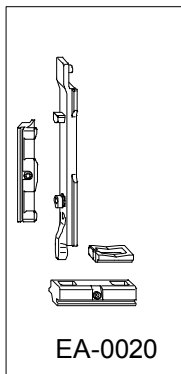

EA-0020

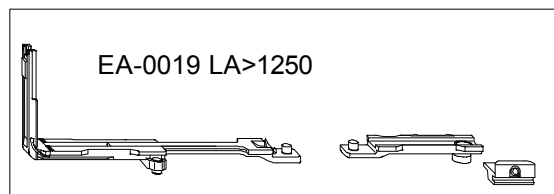

EA-0019 LA>1250

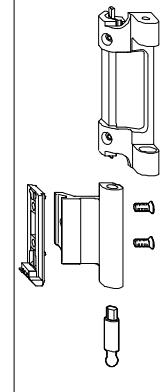

EA-0052

Layout accessori - Accessories Layout

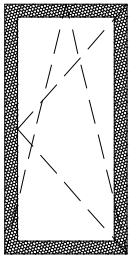

Schema accessori anta ribalta TBT "logica" portata Kg 100/130
One wing Tilt-Turn TBT "logic" scheme accessories capacity Kg 100/130

EA-0026 LA>1250<1600

EA-0106

EA-0019

EA-0024 LA>355<600
EA-0025 LA>601<1250
EA-0026 LA>1251<1600

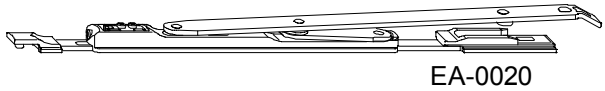

EA-0041

EA-0045

Alternativa EA-0004

EA-0026

EA-0016

EA-0019

EA-0160

Alternativa meccanismo incassato per martellina EA-0021

EA-0019 HA >1250

EA-0022

Campo di impiego finestra:
LA >355<1600 HA >500<2000
Campo di impiego portafinestra:
LA >355<1300 HA >500<2400

EA-0041

EA-0019 LA>1250

EA-0052

Layout accessori - Accessories Layout

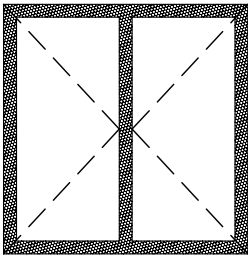

Schema accessori finestra due ante portata Kg 80
Two wing window scheme accessories capacity Kg 80

N.B.: In caso di seconda anta semifissa, aggiungere accessorio EA-0014 (o EA-0014+EA-0015) come Layout pag. 2-18

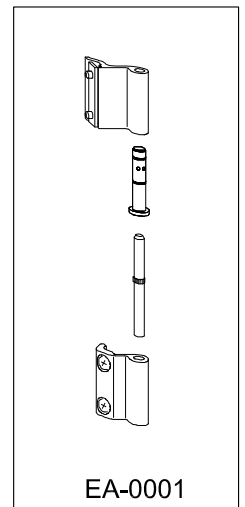
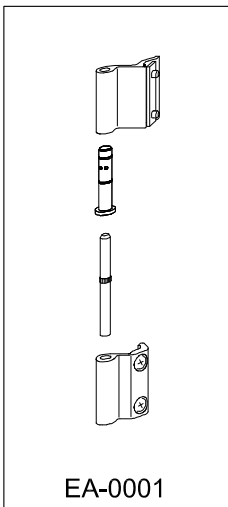
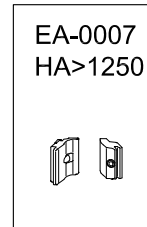
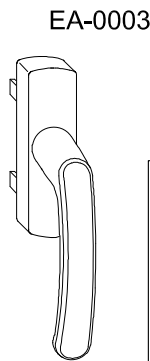
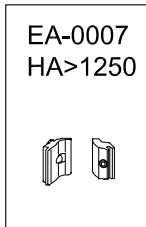
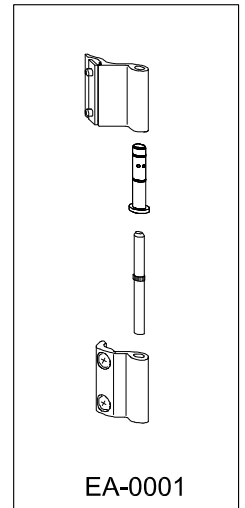
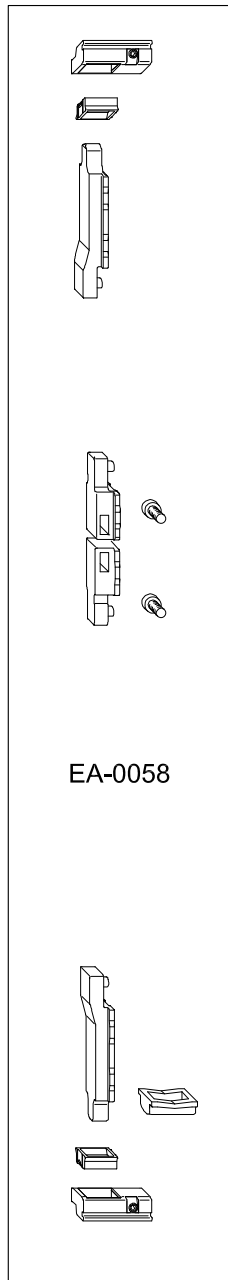
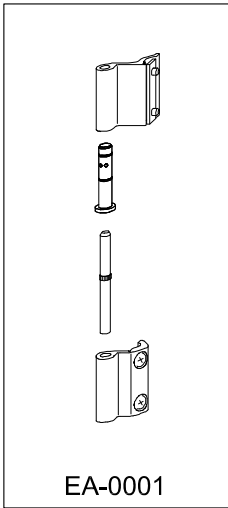

Layout accessori - Accessories Layout

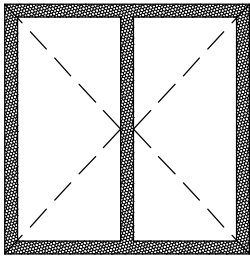

Schema accessori finestra due ante portata Kg 100/130
Two wing window scheme accessories capacity Kg 100/130

N.B.: In caso di seconda anta semifissa, aggiungere accessorio EA-0014 (o EA-0014+EA-0015) come Layout pag. 2-18

EA-0023

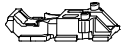

EA-0023

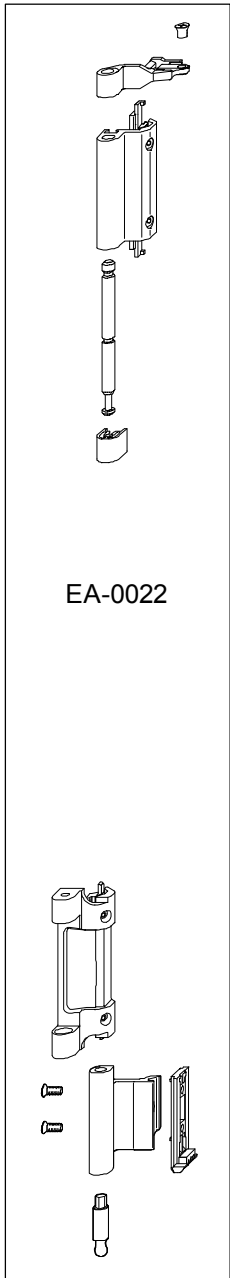
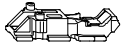

EA-0016

EA-0007
HA>1250

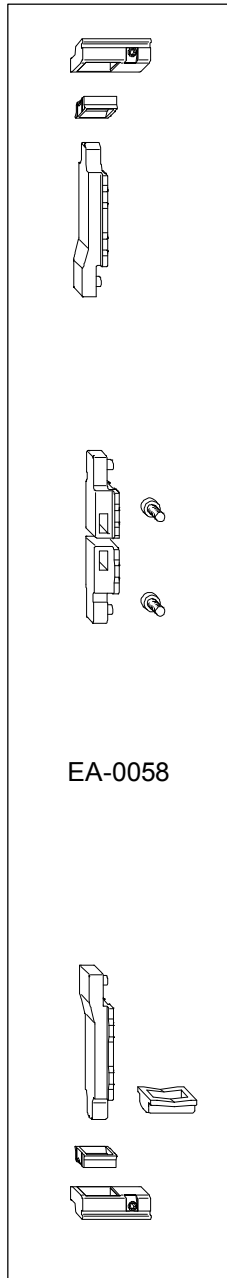

EA-0016

EA-0003

EA-0007
HA>1250

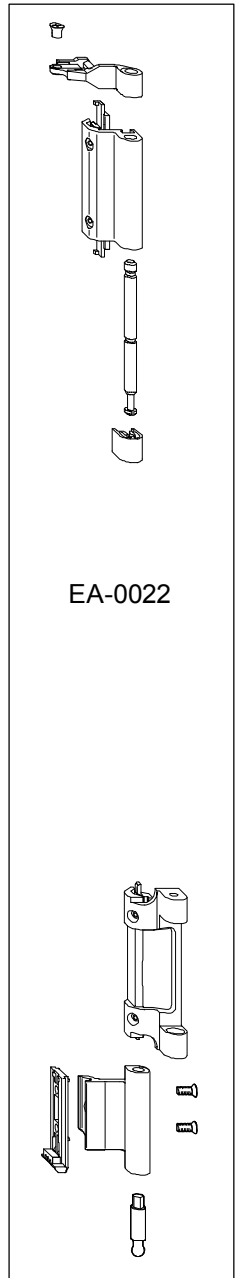

EA-0022

EA-0022

EA-0052

EA-0052

EA-0058

Layout accessori - Accessories Layout

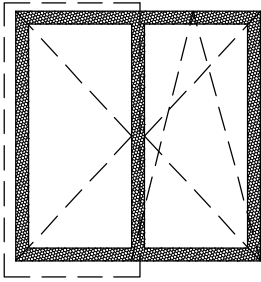

Schema seconda anta tipologia A/R 2 ante Kg 100/130

Second wing scheme accessories 2 wings Tilt-Turn Kg 100/130

Campo di impiego finestra:
LA >375<1250 HA >680<2000
Campo di impiego portafinestra:
LA >375<1300 HA >680<2400

EA-0023

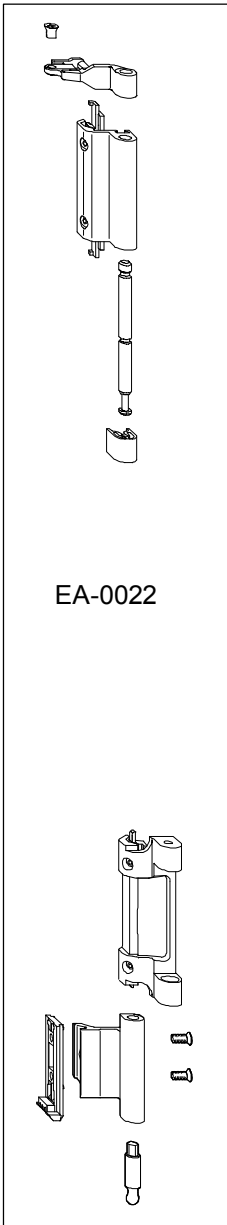
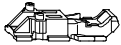

EA-0022

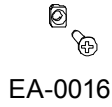

EA-0016

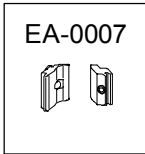

EA-0007

EA-0052

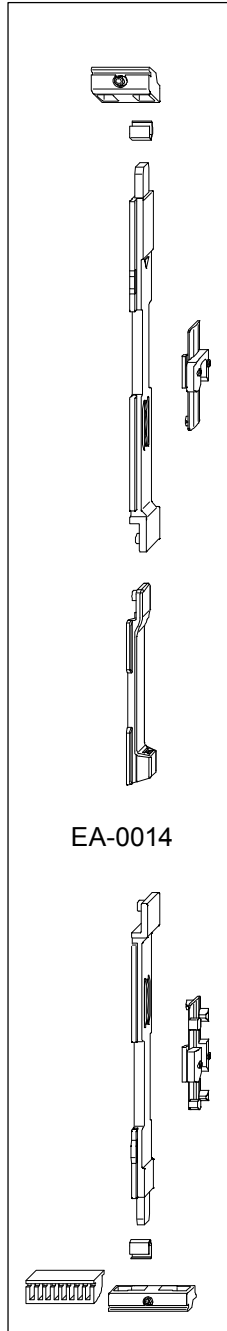

EA-0014

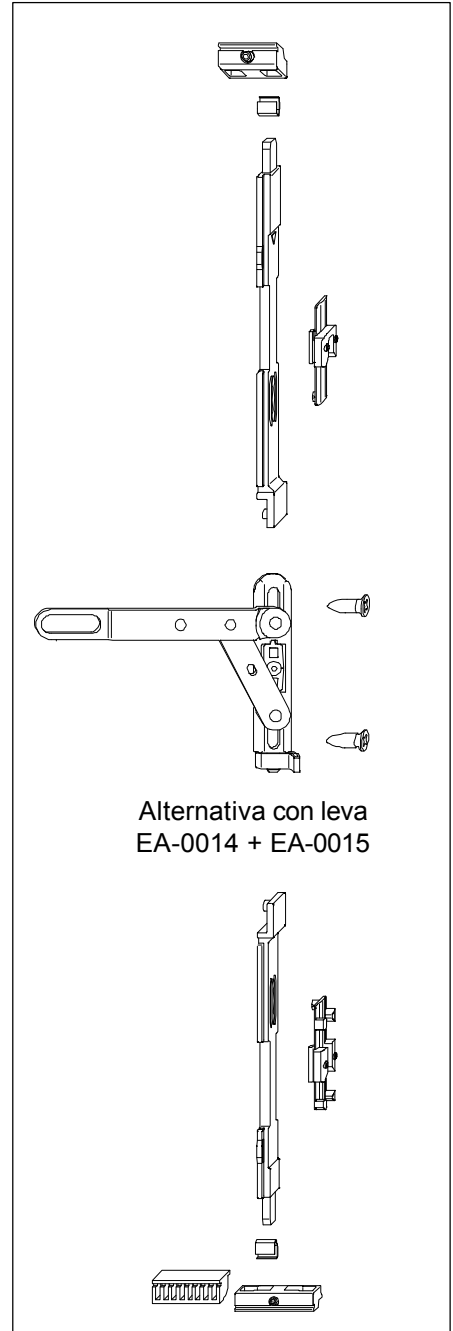

Alternativa con leva
EA-0014 + EA-0015

Layout accessori - Accessories Layout

Schema prima anta tipologia A/R 2 ante Kg 100/130
Main wing scheme accessories 2 wings Tilt-Turn Kg 100/130

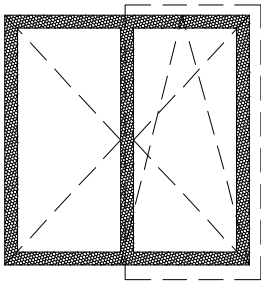

EA-0024 LA>355<600
 EA-0025 LA>601<1250
 EA-0026 LA>1251<1600

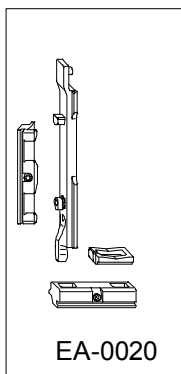
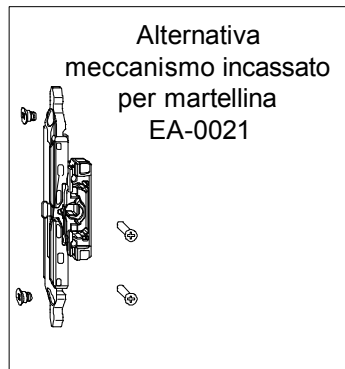
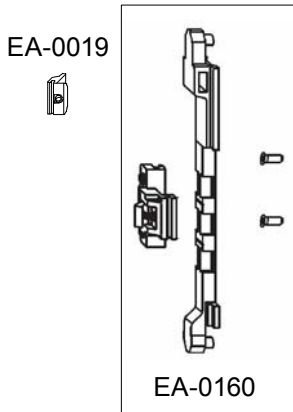
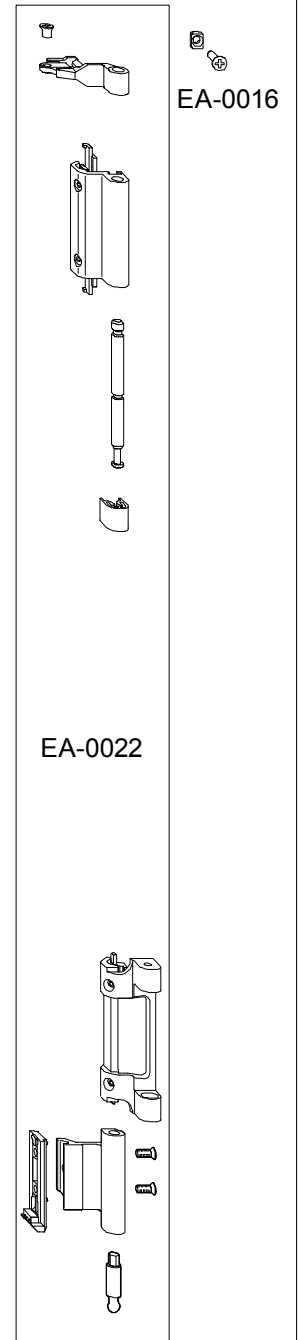
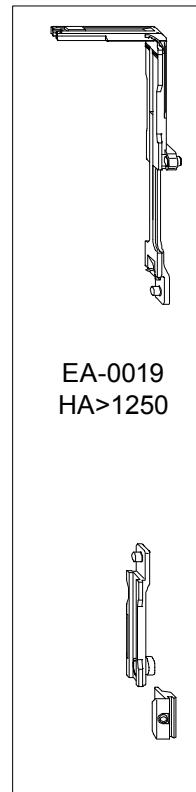
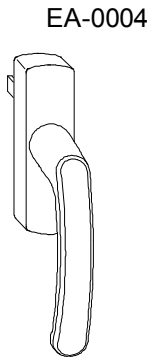
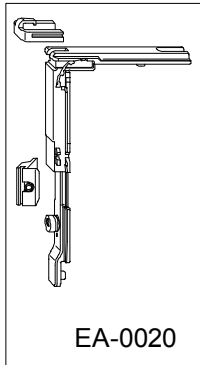
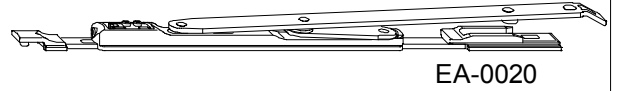
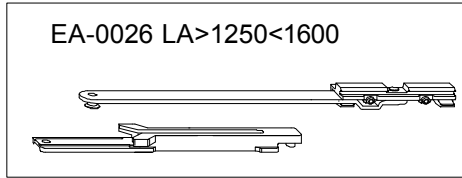

Campo di impiego finestra:
 LA >375<1250 HA >680<2000
 Campo di impiego portafinestra:
 LA >375<1300 HA >680<2400

Layout accessori - Accessories Layout

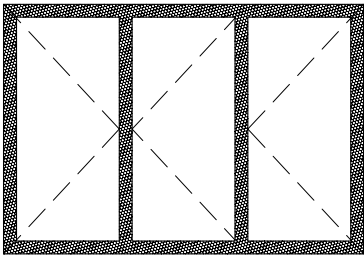

Schema accessori finestra tre ante portata Kg 80
Three wing window scheme accessories capacity Kg 80

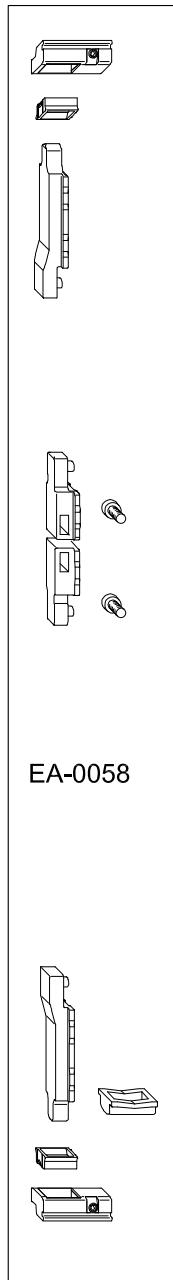
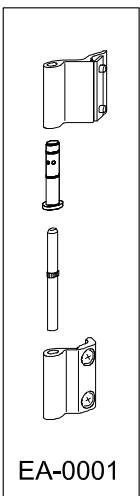
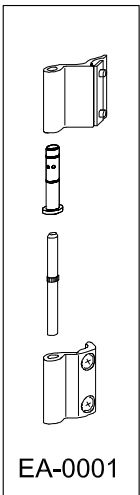

EA-0003

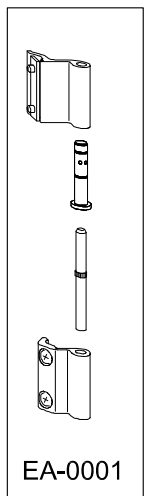
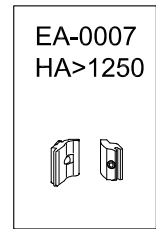
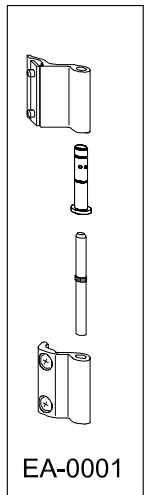
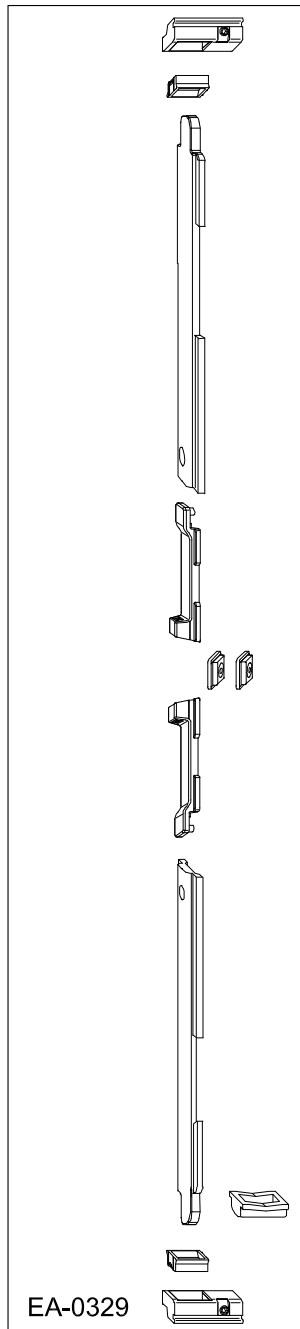
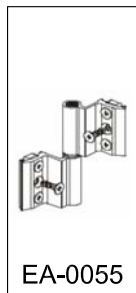
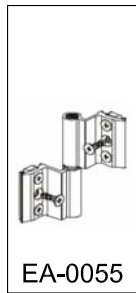
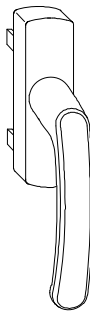

Layout accessori - Accessories Layout

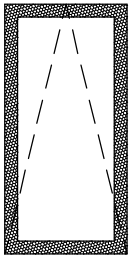

Schema accessori vasistas portata Kg 40/100 maniglia verticale

Hopper window scheme accessories capacity Kg 40/100 vertical handle

Campo di impiego finestra:
LA >520<1600 HA >500<2000

N° 1 EA-0010 + N° 1 EA-0061 LA>520<920 mm max. 40 Kg

N° 2 EA-0010 + N° 2 EA-0061 LA>920<1600 mm max. 100 Kg

Aggiungere chiusura supplementare
centrale presente in accessorio
EA-0060 nel caso LA>920<1600 mm

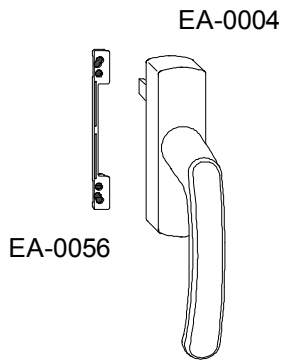
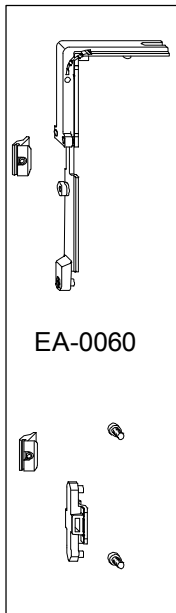

EA-0056

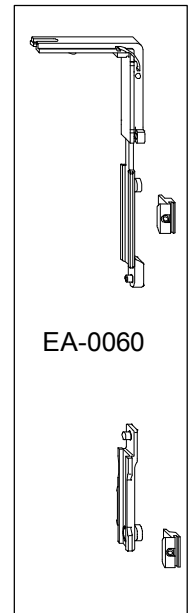
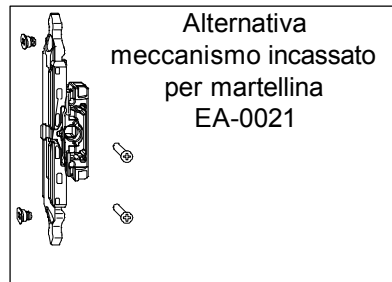

EA-0002

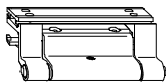

EA-0002

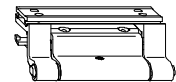

Layout accessori - Accessories Layout

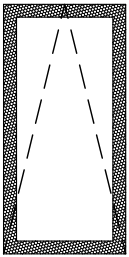

Schema accessori vasistas portata Kg 30/50 maniglia orizzontale
Hopper window scheme accessories capacity Kg 30/50 horizontal handle

Campo di impiego finestra:
LA >400<2400 HA >450<1200

N° 1 EA-0010 LA>400<1000 mm max. 30 Kg
N° 2 EA-0010 LA>1000<2400 mm max. 50 Kg

EA-0007

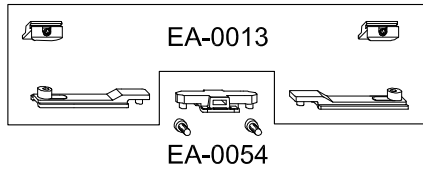

EA-0056



EA-0006

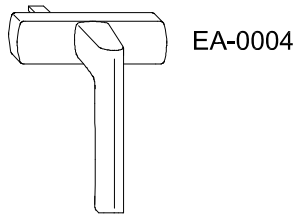
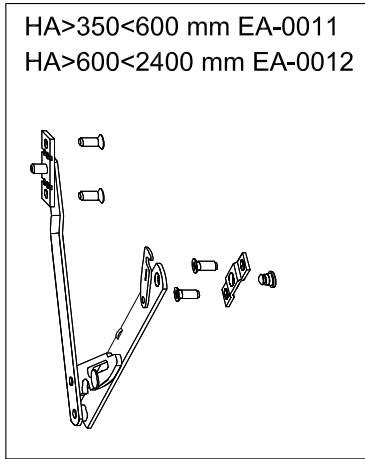

EA-0006

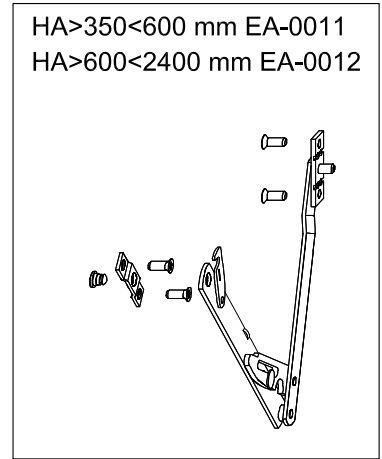



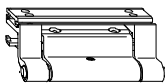



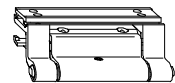



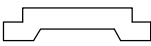







EA-0002









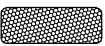







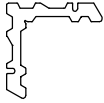

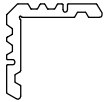

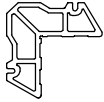









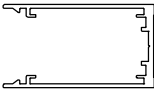

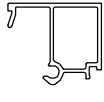
EA-0002



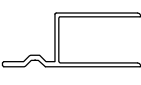

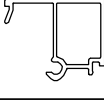





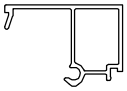

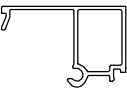







Elenco Profili - Profiles List				
SIGLA CODE	PROFILO PROFILE	PESO Kg/m WEIGHT Kg/m	IMPIEGO USE	PAGINA PAGE
4293		0.183	Fermavetro da 4 mm <i>Glass beading</i>	4-34
5767		0.190	Gocciolatoio <i>Water drainage</i>	4-32
6405		0.159	Astina di comando chiusure <i>Closing rod</i>	4-32
16185		0.237	Fermavetro da 10 mm <i>Glass beading</i>	4-33
16186		0.243	Fermavetro da 13 mm <i>Glass beading</i>	4-33
16189		0.252	Fermavetro da 17 mm <i>Glass beading</i>	4-33
16191		0.290	Fermavetro da 23 mm <i>Glass beading</i>	4-33
16193		0.303	Fermavetro da 27 mm <i>Glass beading</i>	4-33
16195		0.310	Fermavetro da 29 mm <i>Glass beading</i>	4-33
16197		0.316	Fermavetro da 31 mm <i>Glass beading</i>	4-33
19712		0.242	Fermavetro da 15 mm <i>Glass beading</i>	4-33
 19873		0.314	Fermavetro da 13 mm <i>Glass beading</i>	4-34
 19874		0.328	Fermavetro da 17 mm <i>Glass beading</i>	4-34
 19875		0.352	Fermavetro da 23 mm <i>Glass beading</i>	4-34
 19876		0.376	Fermavetro da 29 mm <i>Glass beading</i>	4-34





Note:  = profilo non a stock
profile no stock

Elenco Profili - Profiles List				
SIGLA CODE	PROFILO PROFILE	PESO Kg/m WEIGHT Kg/m	IMPIEGO USE	PAGINA PAGE
 19877		0.385	Fermavetro da 31 mm <i>Glass beading</i>	4-34
 20575		0.235	Coprifilo <i>Cover joint</i>	4-32
22618		0.271	Fermavetro da 20 mm <i>Glass beading</i>	4-33
 22656		2.533	Squadretta a cianfrinare <i>Corner joint to be chamfered</i>	4-40
 22657		2.236	Squadretta a cianfrinare <i>Corner joint to be chamfered</i>	4-40
 22658		2.391	Squadretta a cianfrinare <i>Corner joint to be chamfered</i>	4-40
 22659		2.410	Squadretta a cianfrinare <i>Corner joint to be chamfered</i>	4-40
 22660		2.295	Squadretta a cianfrinare <i>Corner joint to be chamfered</i>	4-41
 22661		3.195	Squadretta a cianfrinare <i>Corner joint to be chamfered</i>	4-41
 24523		0.270	Copertina rinforzo <i>Reinforcement cover</i>	4-39
 24524		1.423	Rinforzo <i>Reinforcement</i>	4-39
 24528		0.366	Fermavetro da 31 mm <i>Glass beading 31 mm</i>	4-36
 24533		0.265	Battuta riportata da 35 mm <i>Additional rabbet 35 mm</i>	4-38
 24534		0.483	Imbotte <i>For expansion profile</i>	4-38
 24556		0.372	Fermavetro da 33 mm <i>Glass beading 33 mm</i>	4-36

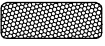

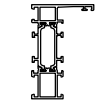
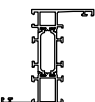
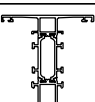
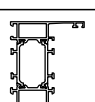
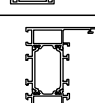
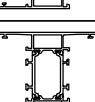
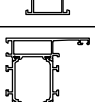
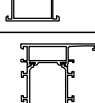
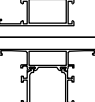
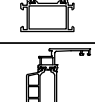

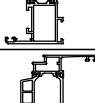
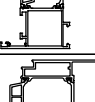
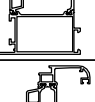

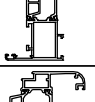
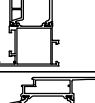
Note:  = profilo non a stock
profile no stock

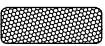
Elenco Profili - Profiles List				
SIGLA CODE	PROFILO PROFILE	PESO Kg/m WEIGHT Kg/m	IMPIEGO USE	PAGINA PAGE
 24557		0.385	Fermavetro da 37 mm <i>Glass beading 37 mm</i>	4-36
 24558		0.392	Fermavetro da 39 mm <i>Glass beading 39 mm</i>	4-37
 24559		0.399	Fermavetro da 41 mm <i>Glass beading 41 mm</i>	4-37
 24560		0.407	Fermavetro da 43 mm <i>Glass beading 43 mm</i>	4-37
 24561		0.414	Fermavetro da 45 mm <i>Glass beading 45 mm</i>	4-37
 24565		0.233	Fermavetro da 4 mm <i>Glass beading 4 mm</i>	4-35
 24566		0.255	Fermavetro da 10 mm <i>Glass beading 10 mm</i>	4-35
 24567		0.265	Fermavetro da 13 mm <i>Glass beading 13 mm</i>	4-35
 24568		0.272	Fermavetro da 15 mm <i>Glass beading 15 mm</i>	4-35
 24569		0.279	Fermavetro da 17 mm <i>Glass beading 17 mm</i>	4-35
 24570		0.332	Fermavetro da 20 mm <i>Glass beading 20 mm</i>	4-35
 24571		0.340	Fermavetro da 23 mm <i>Glass beading 23 mm</i>	4-36
 24572		0.352	Fermavetro da 27 mm <i>Glass beading 27 mm</i>	4-36
 24573		0.359	Fermavetro da 29 mm <i>Glass beading 29 mm</i>	4-36

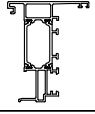
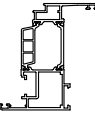
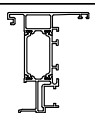
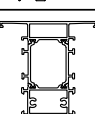

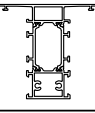
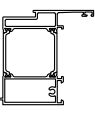
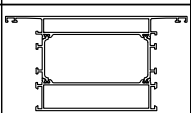

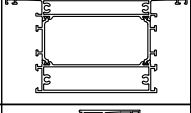
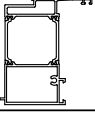
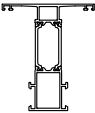
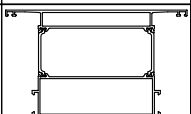

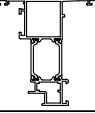
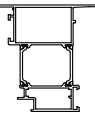
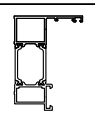



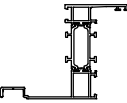

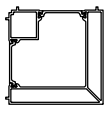
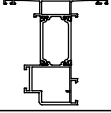
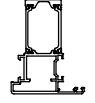
Note:  = profilo non a stock
profile no stock

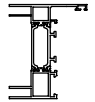
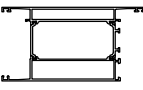
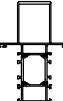
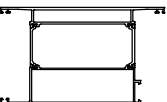
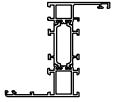
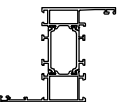
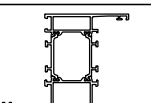
Elenco Profili - Profiles List				
SIGLA CODE	PROFILO PROFILE	PESO Kg/m WEIGHT Kg/m	IMPIEGO USE	PAGINA PAGE
TT78-01		1.390	Telaio fisso L piccolo <i>Small L-fixed frame</i>	4-01
TT78-02		1.523	Telaio fisso Z piccolo <i>Small Z-fixed frame</i>	4-01
TT78-03		1.517	Telaio fisso T piccolo <i>Small T-fixed frame</i>	4-02
TT78-04		1.606	Telaio fisso L medio <i>Medium L-fixed frame</i>	4-02
TT78-05		1.739	Telaio fisso Z medio <i>Medium Z-fixed frame</i>	4-03
TT78-06		1.731	Telaio fisso T medio <i>Medium T-fixed frame</i>	4-03
TT78-07		1.764	Telaio fisso L maggiorato <i>Oversize L-fixed frame</i>	4-04
TT78-08		1.897	Telaio fisso Z maggiorato <i>Oversize Z-fixed frame</i>	4-04
TT78-09		1.891	Telaio fisso T maggiorato <i>Oversize T-fixed frame</i>	4-05
TT78-10		1.561	Anta piccola <i>Small wing</i>	4-12
 TT78-11		1.780	Anta media <i>Medium wing</i>	4-12
TT78-12		2.139	Anta maggiorata <i>Oversize wing</i>	4-13
TT78-16		1.623	Anta piccola stondata <i>Small rounded wing</i>	4-26
 TT78-17		1.842	Anta media stondata <i>Medium rounded wing</i>	4-26
TT78-18		2.200	Anta maggiorata stondata <i>Oversize rounded wing</i>	4-27

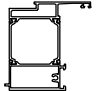
Note:  = profilo non a stock
profile no stock

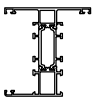
Elenco Profili - Profiles List				
SIGLA CODE	PROFILO PROFILE	PESO Kg/m WEIGHT Kg/m	IMPIEGO USE	PAGINA PAGE
TT78-19		1.568	Battuta riportata <i>Central rabbet</i>	4-14
TT78-22		1.874	Anta per pista 16 <i>Euro groove 16 mm wing</i>	4-14
TT78-25		1.614	Battuta riportata per pista 16 <i>Euro groove 16 mm wing central rabbet</i>	4-18
TT78-27		2.022	T da 94 mm per telai fissi <i>T-profile 94 mm for fixed frames</i>	4-06
 TT78-28		1.862	T da 86 mm per telai fissi <i>T-profile 86 mm for fixed frames</i>	4-06
TT78-29		1.893	Zoccolo riportato per telai fissi <i>Lower additional transom for fixed frames</i>	4-07
TT78-30		3.011	Fascia da 150 mm per telai fissi <i>Horizontal transom 150 mm for fixed frames</i>	4-08
 TT78-31		3.273	Fascia da 150 mm per telai fissi <i>Horizontal transom 150 mm for fixed frames</i>	4-09
TT78-32		1.928	Zoccolo riportato per ante complanari <i>Lower additional transom for coplanar wings</i>	4-10
TT78-33		1.573	T da 76 mm per ante complanari <i>T-profile 76 mm for coplanar wings</i>	4-10
TT78-34		3.055	Fascia da 150 mm per ante complanari <i>Horizontal transom 150 mm for coplanar wings</i>	4-11
TT78-36		0.859	Soglia ridotta <i>Small threshold</i>	4-17
 TT78-37		1.768	Anta apertura esterna <i>External opening wing</i>	4-16
TT78-38		2.128	Anta maggiorata apertura esterna <i>Oversize external opening wing</i>	4-16
TT78-39		1.374	Inversione di battuta <i>Frame rabbet inversion</i>	4-07

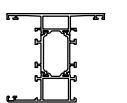
Note:  = profilo non a stock
profile no stock

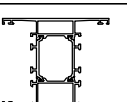
Elenco Profili - Profiles List				
SIGLA CODE	PROFILO PROFILE	PESO Kg/m WEIGHT Kg/m	IMPIEGO USE	PAGINA PAGE
 TT78-40		1.654	Telaio fisso Z per ristrutturazioni <i>Z-fixed frame</i>	4-17
 TT78-41		2.383	Montante d'angolo <i>Corner Jamb</i>	4-25
TT78-44		1.864	Anta per bilico <i>For wing of pivoting window</i>	4-15
TT78-45		1.640	Inversione di battuta per bilico <i>Inversion of rabbet for pivoting window</i>	4-15
 TT78-46		1.522	Telaio per giunto <i>Frame for joint</i>	4-18
TT78-47		3.069	Zoccolo da 150 mm per telai fissi <i>Lower transom 150 mm for fixed frames</i>	4-19
TT78-48		2.694	Pilastrino <i>Mullion</i>	4-20
TT78-50		3.145	Zoccolo da 150 mm per ante complanari <i>Lower transom 150 mm for complanar wings</i>	4-21
TT78-51		1.585	Telaio fisso Z piccolo battuta 35 mm <i>Small Z-fixed frame 35 mm</i>	4-22
TT78-52		1.800	Telaio fisso Z medio battuta 35 mm <i>Medium Z-fixed frame 35 mm</i>	4-23
TT78-53		1.958	Telaio fisso Z maggiorato battuta 35 mm <i>Oversized Z-fixed frame 35 mm</i>	4-24
 TT78-54		1.855	Zoccolo riportato per ante sagomate/stondate <i>Lower additional transom for shaped/rounded wings</i>	4-28
 TT78-62		1.650	Telaio fisso H piccolo <i>Small H-fixed frame</i>	4-29
 TT78-63		1.684	Telaio fisso H medio <i>Medium H-fixed frame</i>	4-29
 TT78-64		2.024	Telaio fisso H maggiorato <i>Oversize H-fixed frame</i>	4-30

Note:  = profilo non a stock
profile no stock

Profili 1:1 - Profiles 1:1

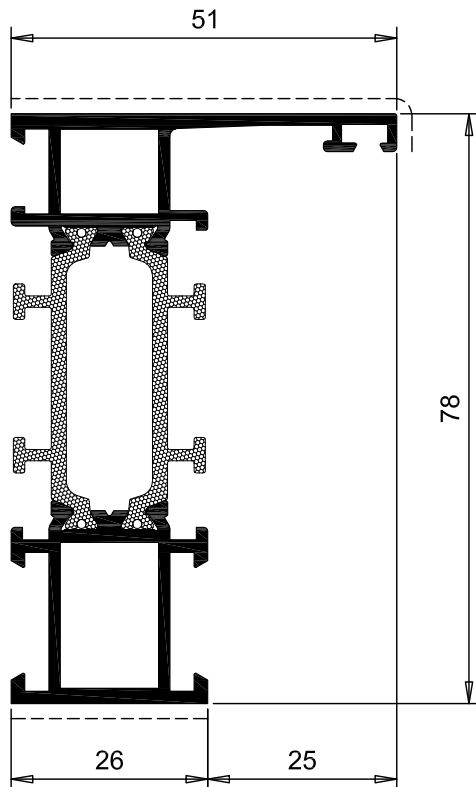

TT78-01	TELAIO FISSO L PICCOLO SMALL L-FIXED FRAME			
	PESO WEIGHT	PERIMETRO PERIMETER	SUP. VISTA SHOWN SURF.	J _x J _y
Kg/m	mm	mm	cm ⁴ cm ⁴	
1.390	430	82	36.39 5.57	

ACCESSORI / ACCESSORIES			
SQUADRETTE / CORNER JOINT			
INT.			EXT.
BOTTONE BUTTON	CIANFRINARE CALKING	SPINARE PINNING	CIANFRINARE CALKING
-	174-1801	174-1801	*153-0057
ALLINEAMENTO / ALIGNMENT		ANG. VAR. / ADJUST. CORNER	
INT.	EXT.	INT.	EXT.
-	174-1591	-	-

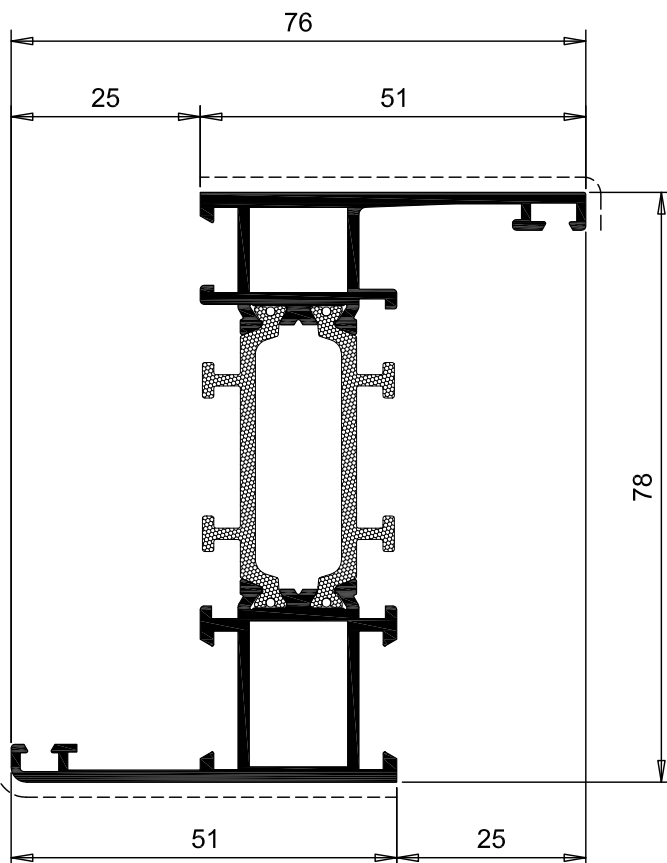

TT78-02	TELAIO FISSO Z PICCOLO SMALL Z-FIXED FRAME			
	PESO WEIGHT	PERIMETRO PERIMETER	SUP. VISTA SHOWN SURF.	J _x J _y
Kg/m	mm	mm	cm ⁴ cm ⁴	
1.523	498	112	44.12 9.85	

ACCESSORI / ACCESSORIES			
SQUADRETTE / CORNER JOINT			
INT.			EXT.
BOTTONE BUTTON	CIANFRINARE CALKING	SPINARE PINNING	CIANFRINARE CALKING
-	174-1801	174-1801	*153-0057
ALLINEAMENTO / ALIGNMENT		ANG. VAR. / ADJUST. CORNER	
INT.	EXT.	INT.	EXT.
-	174-1591	-	-

Note: * = possibilità di fissaggio con grano art. 535-090.19
joint fixing available with hexagon socket set screw item 535-090.19

Profili 1:1 - Profiles 1:1

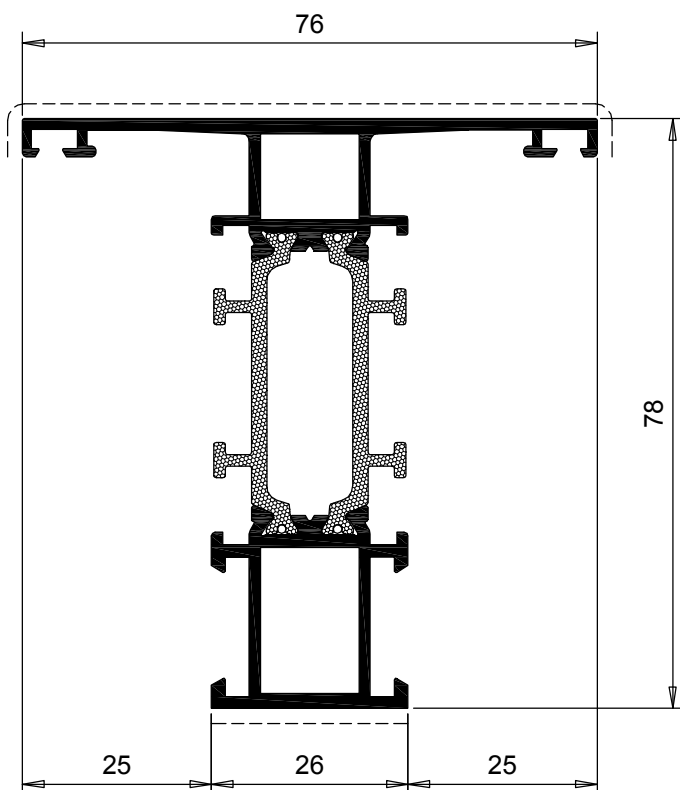

TT78-03	TELAIO FISSO T PICCOLO <i>SMALL T-FIXED FRAME</i>		Y X—X Y	
	PESO WEIGHT	PERIMETRO PERIMETER	SUP. VISTA SHOWN SURF.	J _x
Kg/m	mm	mm	cm ⁴	cm ⁴
1.517	497	112	41.11	9.95

ACCESSORI / ACCESSORIES			
SQUADRETTE / CORNER JOINT			
INT.		EXT.	
BOTTONE BUTTON	CIANFRINARE CALKING	SPINARE PINNING	CIANFRINARE CALKING
-	174-1801	174-1801	*153-0057
ALLINEAMENTO / ALIGNMENT		ANG. VAR. / ADJUST. CORNER	
INT.	EXT.	INT.	EXT.
-	174-1591	-	-
CAVALLOTTI / T-JOINT			
INT.	EXT.		
	ANTA / WING	TELAIO / FIXED FRAME	
EA-0133	EA-0032	174-1591+EA-0137	

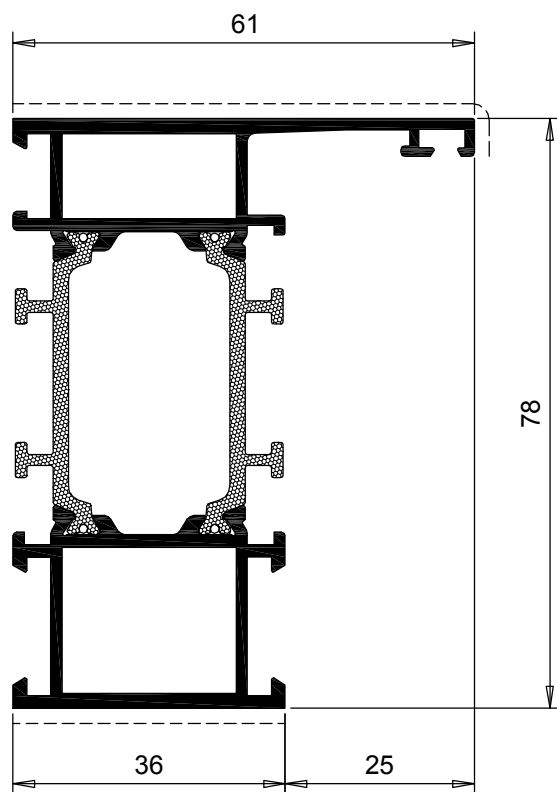

TT78-04	TELAIO FISSO L MEDIO <i>MEDIUM L-FIXED FRAME</i>		Y X—X Y	
	PESO WEIGHT	PERIMETRO PERIMETER	SUP. VISTA SHOWN SURF.	J _x
Kg/m	mm	mm	cm ⁴	cm ⁴
1.606	450	102	43.91	10.40

ACCESSORI / ACCESSORIES			
SQUADRETTE / CORNER JOINT			
INT.		EXT.	
BOTTONE BUTTON	CIANFRINARE CALKING	SPINARE PINNING	CIANFRINARE CALKING
-	174-1803	174-1803	*153-0059
ALLINEAMENTO / ALIGNMENT		ANG. VAR. / ADJUST. CORNER	
INT.	EXT.	INT.	EXT.
-	174-1591	-	-

Note: * = possibilità di fissaggio con grano art. 535-090.19
joint fixing available with hexagon socket set screw item 535-090.19

Profili 1:1 - Profiles 1:1

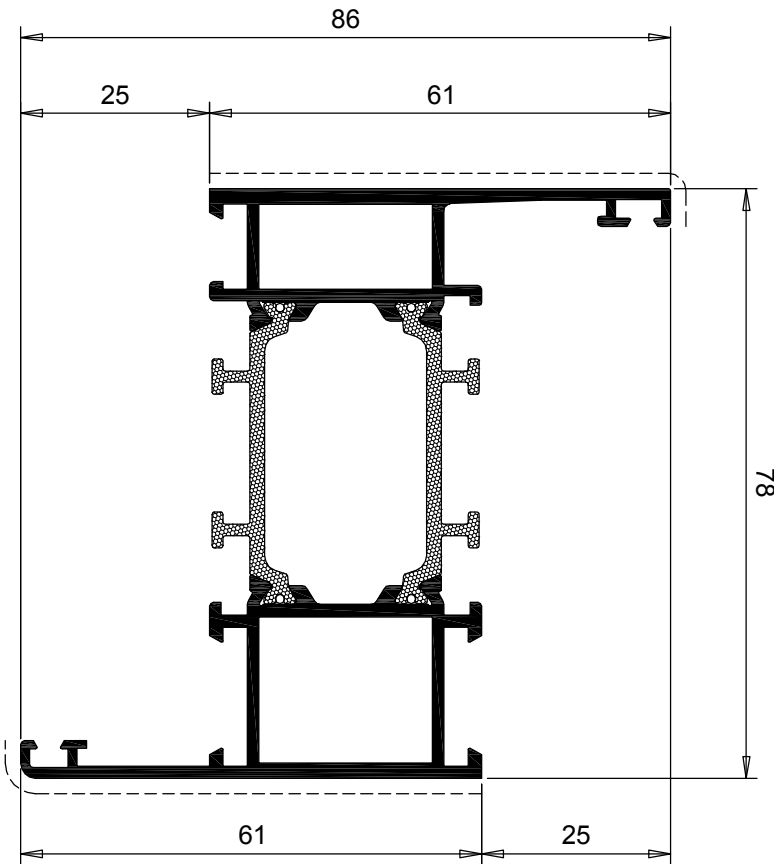

TT78-05	TELAIO FISSO Z MEDIO <i>MEDIUM Z-FIXED FRAME</i>			
	PESO WEIGHT Kg/m	PERIMETRO PERIMETER mm	SUP. VISTA SHOWN SURF. mm	J _x cm ⁴
1.739	518	132	51.63	16.19

ACCESSORI / ACCESSORIES			
SQUADRETTE / CORNER JOINT			
INT.		EXT.	
BOTTONE BUTTON	CIANFRINARE CALKING	SPINARE PINNING	CIANFRINARE CALKING
-	174-1803	174-1803	*153-0059
ALLINEAMENTO / ALIGNMENT		ANG. VAR. / ADJUST. CORNER	
INT.	EXT.	INT.	EXT.
-	174-1591	-	-

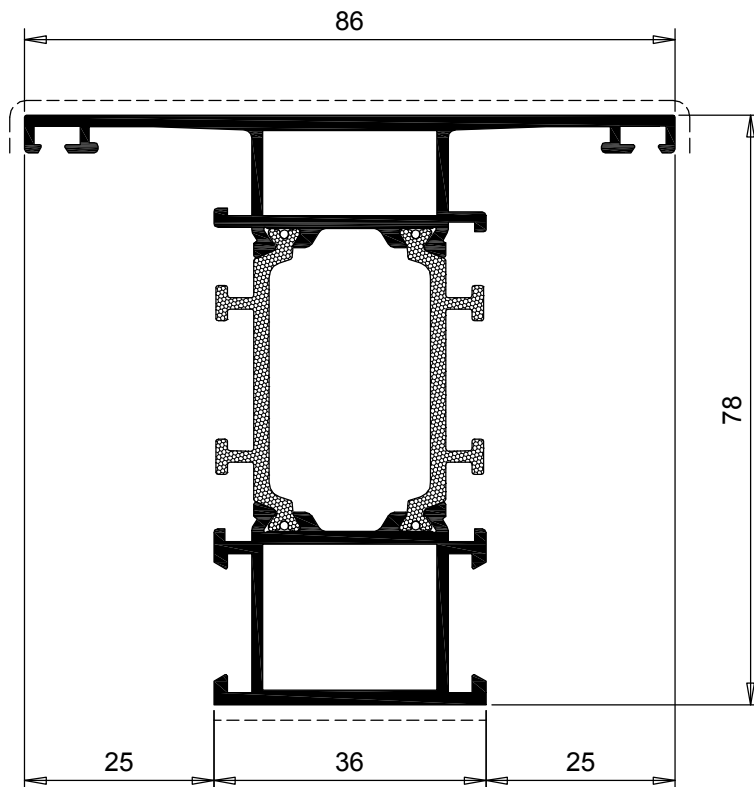

TT78-06	TELAIO FISSO T MEDIO <i>MEDIUM T-FIXED FRAME</i>			
	PESO WEIGHT Kg/m	PERIMETRO PERIMETER mm	SUP. VISTA SHOWN SURF. mm	J _x cm ⁴
1.731	516	132	48.84	16.30

ACCESSORI / ACCESSORIES			
SQUADRETTE / CORNER JOINT			
INT.		EXT.	
BOTTONE BUTTON	CIANFRINARE CALKING	SPINARE PINNING	CIANFRINARE CALKING
-	174-1803	174-1803	*153-0059
ALLINEAMENTO / ALIGNMENT		ANG. VAR. / ADJUST. CORNER	
INT.	EXT.	INT.	EXT.
-	174-1591	-	-
CAVALLOTTI / T-JOINT			
INT.	EXT.		
	ANTA / WING	TELAIO / FIXED FRAME	
EA-0134	EA-0032	174-1591+EA-0138	

Note: * = possibilità di fissaggio con grano art. 535-090.19
joint fixing available with hexagon socket set screw item 535-090.19

Profili 1:1 - Profiles 1:1

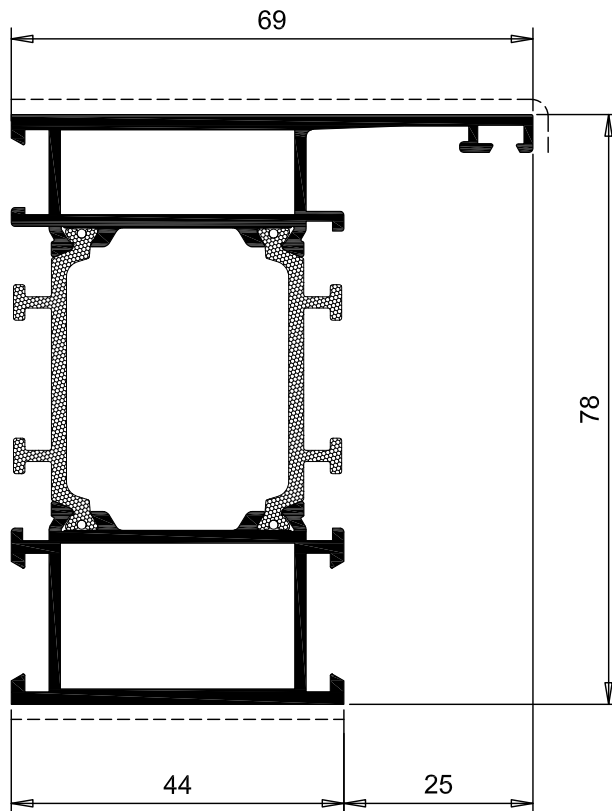

TT78-07	TELAIO FISSO L MAGGIORATO			
	OVERSIZE L-FIXED FRAME			
PESO WEIGHT	PERIMETRO PERIMETER	SUP. VISTA SHOWN SURF.	J _x	J _y
Kg/m	mm	mm	cm ⁴	cm ⁴
1.764	466	118	49.76	16.01

ACCESSORI / ACCESSORIES			
SQUADRETTE / CORNER JOINT			
INT.			EXT.
BOTTONE BUTTON	CIANFRINARE CALKING	SPINARE PINNING	CIANFRINARE CALKING
-	174-1805	174-1805	*153-0061
ALLINEAMENTO / ALIGNMENT		ANG. VAR. / ADJUST. CORNER	
INT.	EXT.	INT.	EXT.
-	174-1591	-	-

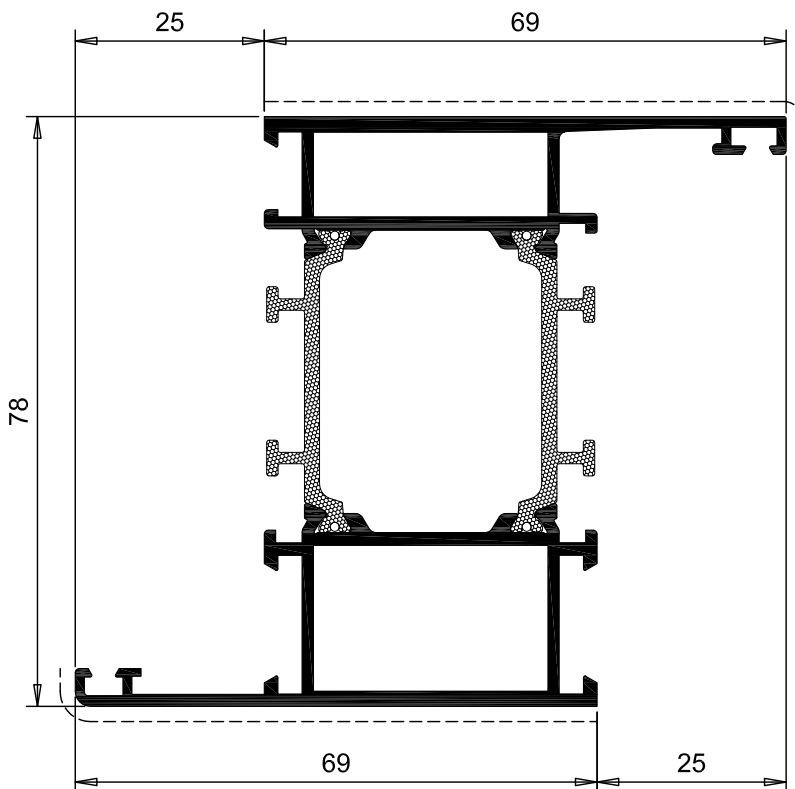

TT78-08	TELAIO FISSO Z MAGGIORATO			
	OVERSIZE Z-FIXED FRAME			
PESO WEIGHT	PERIMETRO PERIMETER	SUP. VISTA SHOWN SURF.	J _x	J _y
Kg/m	mm	mm	cm ⁴	cm ⁴
1.897	534	132	57.48	23.21

ACCESSORI / ACCESSORIES			
SQUADRETTE / CORNER JOINT			
INT.			EXT.
BOTTONE BUTTON	CIANFRINARE CALKING	SPINARE PINNING	CIANFRINARE CALKING
-	174-1805	174-1805	*153-0061
ALLINEAMENTO / ALIGNMENT		ANG. VAR. / ADJUST. CORNER	
INT.	EXT.	INT.	EXT.
-	174-1591	-	-

Note: * = possibilità di fissaggio con grano art. 535-090.19
joint fixing available with hexagon socket set screw item 535-090.19

Profili 1:1 - Profiles 1:1

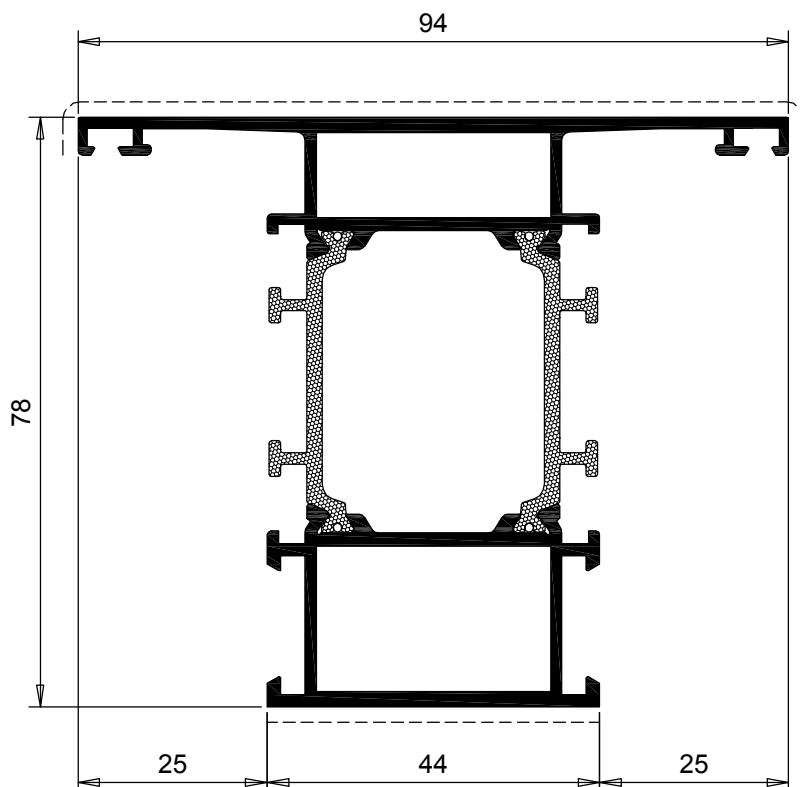

TT78-09	TELAIO FISSO T MAGGIORATO		Y X—X Y	
	OVERSIZE T-FIXED FRAME			
PESO WEIGHT	PERIMETRO PERIMETER	SUP. VISTA SHOWN SURF.	J _x	J _y
Kg/m	mm	mm	cm ⁴	cm ⁴
1.891	533	148	54.78	23.28

ACCESSORI / ACCESSORIES			
SQUADRETTE / CORNER JOINT			
INT.		EXT.	
BOTTONE BUTTON	CIANFRINARE CALKING	SPINARE PINNING	CIANFRINARE CALKING
-	174-1805	174-1805	*153-0061
ALLINEAMENTO / ALIGNMENT		ANG. VAR. / ADJUST. CORNER	
INT.	EXT.	INT.	EXT.
-	174-1591	-	-
CAVALLOTTI / T-JOINT			
INT.	EXT.		
	ANTA / WING	TELAIO / FIXED FRAME	
EA-0135	EA-0032	174-1591+EA-0139	

Note: * = possibilità di fissaggio con grano art. 535-090.19
joint fixing available with hexagon socket set screw item 535-090.19

Profili 1:1 - Profiles 1:1

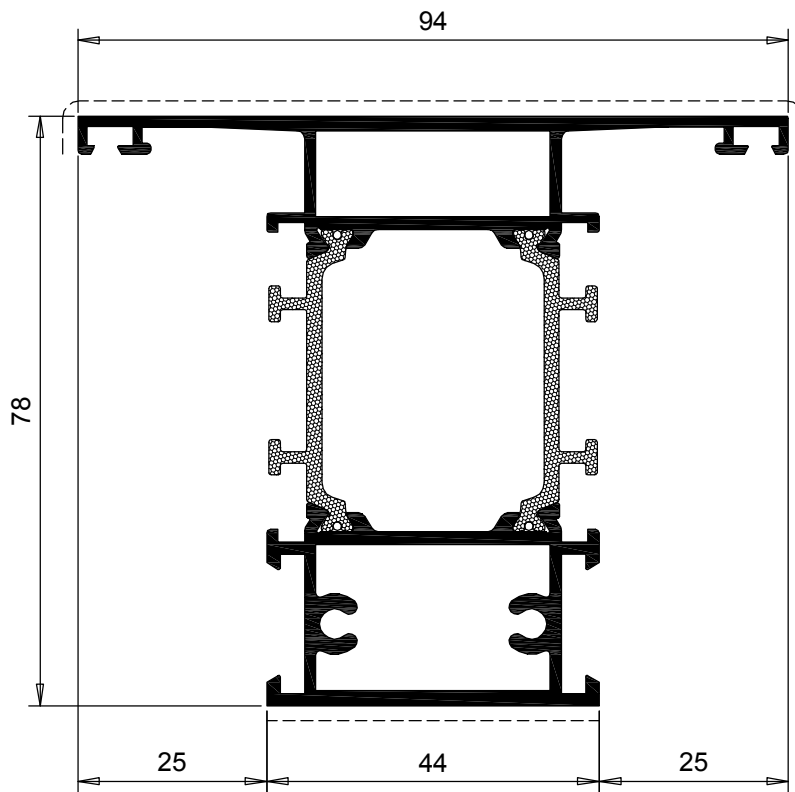

TT78-27	T DA 94 mm PER PROFILI SEZ. 78 mm T-PROFILE 94 mm FOR mm 78 SECTION PROFILES			Y X—X Y	
	PESO WEIGHT	PERIMETRO PERIMETER	SUP. VISTA SHOWN SURF.	J _x	J _y
	Kg/m	mm	mm	cm ⁴	cm ⁴
	2.022	533	148	60.19	24.13

ACCESSORI / ACCESSORIES		
CAVALLOTTI / T-JOINT		
INT.	EXT.	
	ANTA / WING	TELAIO / FIXED FRAME
-	-	174-1591+EA-0139

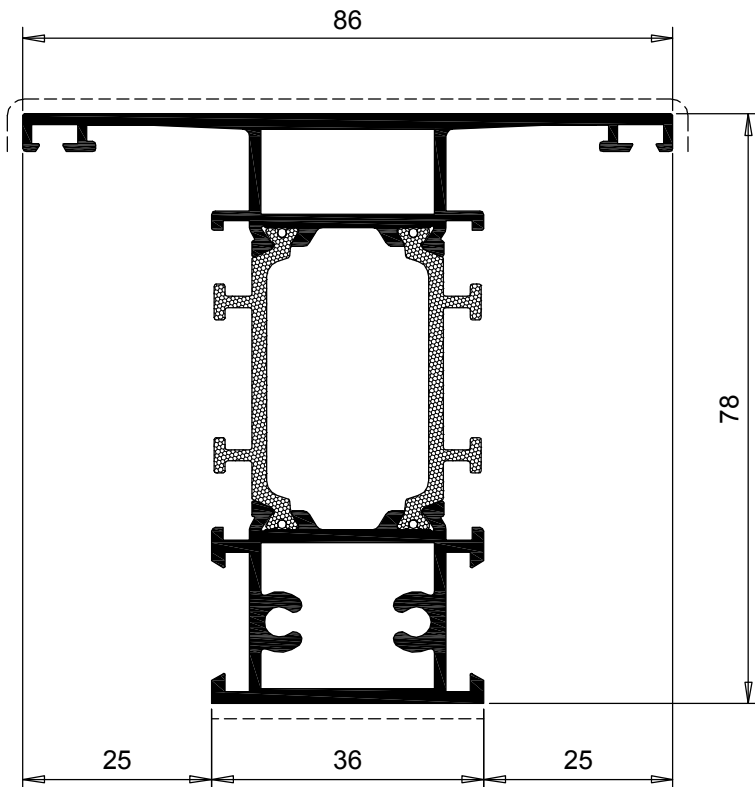

TT78-28	T DA 86 mm PER PROFILI SEZ. 78 mm T-PROFILE 86 mm FOR mm 78 SECTION PROFILES			Y X—X Y	
	PESO WEIGHT	PERIMETRO PERIMETER	SUP. VISTA SHOWN SURF.	J _x	J _y
	Kg/m	mm	mm	cm ⁴	cm ⁴
	1.862	517	132	54.37	16.72

ACCESSORI / ACCESSORIES		
CAVALLOTTI / T-JOINT		
INT.	EXT.	
	ANTA / WING	TELAIO / FIXED FRAME
-	-	174-1591+EA-0138

Note:  = profilo non a stock
profile no stock

Note: * = possibilità di fissaggio con grano art. 535-090.19
joint fixing available with hexagon socket set screw item 535-090.19

Profili 1:1 - Profiles 1:1

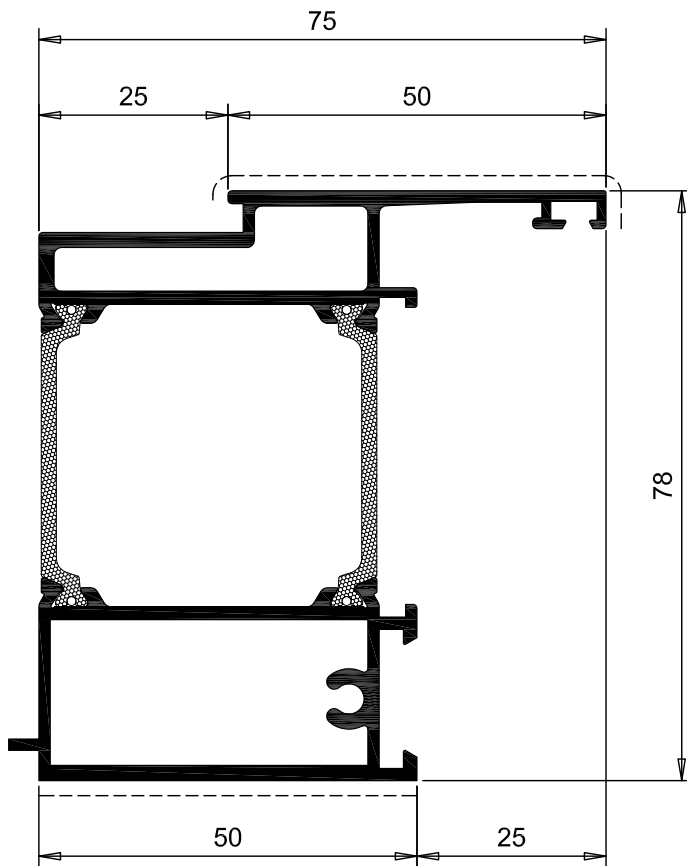

TT78-29	ZOCOLO RIPORTATO PER PROFILI SEZ. 78mm LOWER ADDITIONAL TRANSOM FOR mm 78 SECTION PROFILES			
	PESO WEIGHT	PERIMETRO PERIMETER	SUP. VISTA SHOWN SURF.	J _x J _y
Kg/m	mm	mm	cm ⁴ cm ⁴	
1.893	383	107	55.11 23.02	

ACCESSORI / ACCESSORIES			
CAVALLOTTI / T-JOINT			
INT.	EXT.		
	ANTA / WING	TELAIO / FIXED FRAME	
-	-	174-1591	

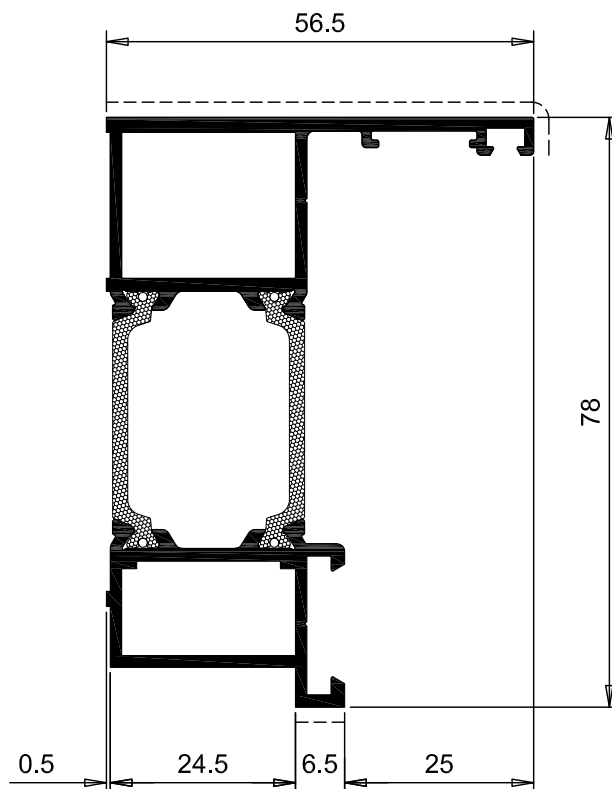

TT78-39	INVERSIONE DI BATTUTA FRAME RABBET INVERSION			
	PESO WEIGHT	PERIMETRO PERIMETER	SUP. VISTA SHOWN SURF.	J _x J _y
Kg/m	mm	mm	cm ⁴ cm ⁴	
1.374	323	68	34.18 8.63	

ACCESSORI / ACCESSORIES			
SQUADRETTE / CORNER JOINT			
INT.			EXT.
BOTTONE BUTTON	CIANFRINARE CALKING	SPINARE PINNING	CIANFRINARE CALKING
-	174-1803	174-1803	*153-0059
ALLINEAMENTO / ALIGNMENT		ANG. VAR. / ADJUST. CORNER	
INT.	EXT.	INT.	EXT.
153-040.4	-	-	-

Note: * = possibilità di fissaggio con grano art. 535-090.19
joint fixing available with hexagon socket set screw item 535-090.19

Profili 1:1 - Profiles 1:1

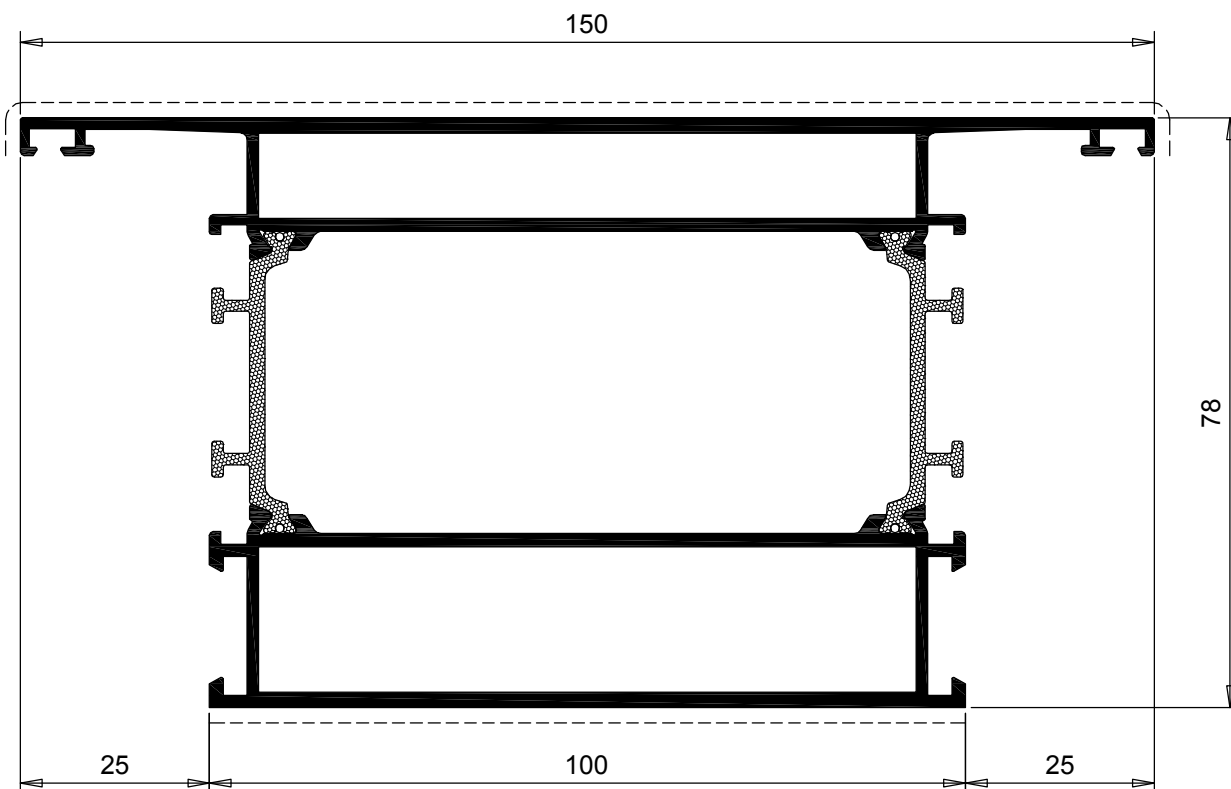

TT78-30	FASCIA DA 150 MM PER TELAI FISSI			
	HORIZONTAL TRANSOM 150 mm FOR FIXED FRAMES			
PESO WEIGHT	PERIMETRO PERIMETER	SUP. VISTA SHOWN SURF.	J _x	J _y
Kg/m	mm	mm	cm ⁴	cm ⁴
3.011	645	260	96.12	136.79

ACCESSORI / ACCESSORIES		
CAVALLOTTI / T-JOINT		
INT.	EXT.	
	ANTA / WING	TELAIO / FIXED FRAME
EA-0135	EA-0032	174-1591+EA-0139

Profili 1:1 - Profiles 1:1

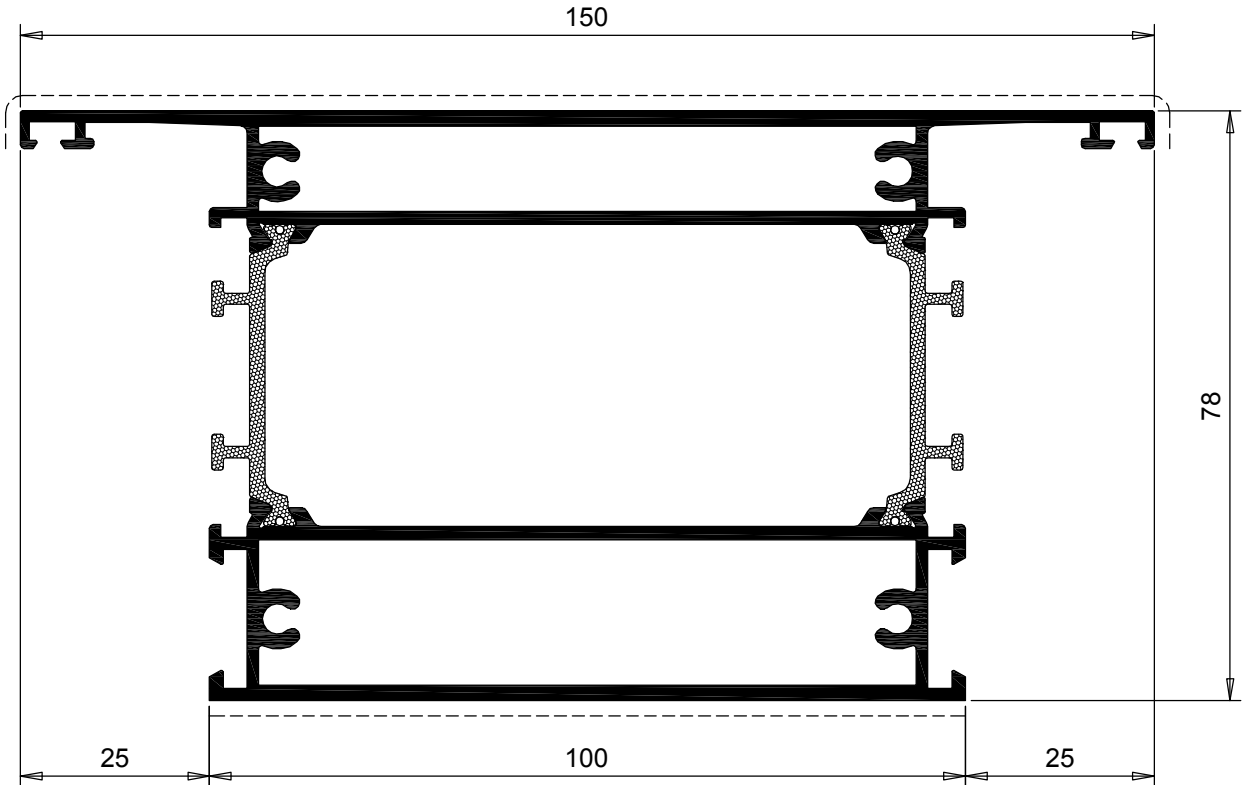

TT78-31	FASCIA DA 150 MM PER TELAI FISSI		Y X — X Y	
	HORIZZONTAL TRANSOM 150 mm FOR FIXED FRAMES		J _x	J _y
PESO WEIGHT	PERIMETRO PERIMETER	SUP. VISTA SHOWN SURF.	cm ⁴	cm ⁴
Kg/m	mm	mm	104.76	153.13
3.273	645	260		

ACCESSORI / ACCESSORIES		
CAVALLOTTI / T-JOINT		
INT.	EXT.	
	ANTA / WING	TELAIO / FIXED FRAME
-	-	174-1591

Note: = profilo non a stock
profile no stock

Profili 1:1 - Profiles 1:1

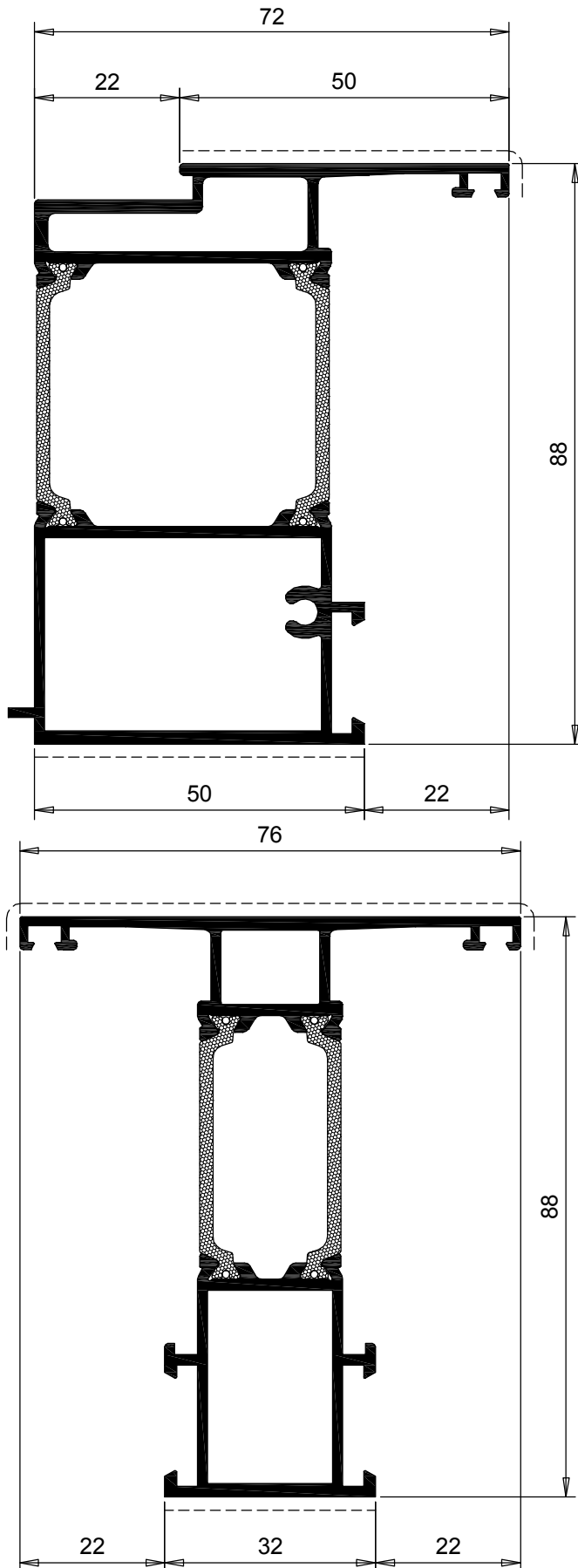

TT78-32	ZOCOLO RIPORTATO PER ANTE COMPLANARI LOWER ADDITIONAL TRANSOM FOR COPLANAR WINGS		$\begin{matrix} Y \\ X \rightarrow X \\ \leftarrow Y \end{matrix}$	
	PESO WEIGHT	PERIMETRO PERIMETER	SUP. VISTA SHOWN SURF.	$\begin{matrix} J_x & J_y \\ \leftarrow & \rightarrow \end{matrix}$
Kg/m	mm	mm	cm ⁴	cm ⁴
1.928	382	105	68.82	22.58

ACCESSORI / ACCESSORIES		
CAVALLOTTI / T-JOINT		
INT.	EXT.	
	ANTA / WING	TELAIO / FIXED FRAME
-	-	174-1591

TT78-33	T DA 76 mm PER ANTE COMPLANARI T-PROFILE 76 mm FOR COPLANAR WINGS		$\begin{matrix} Y \\ X \rightarrow X \\ \leftarrow Y \end{matrix}$	
	PESO WEIGHT	PERIMETRO PERIMETER	SUP. VISTA SHOWN SURF.	$\begin{matrix} J_x & J_y \\ \leftarrow & \rightarrow \end{matrix}$
Kg/m	mm	mm	cm ⁴	cm ⁴
1.573	435	118	57.88	11.24

ACCESSORI / ACCESSORIES		
CAVALLOTTI / T-JOINT		
INT.	EXT.	
	ANTA / WING	TELAIO / FIXED FRAME
EA-0136	174-1591	-

Profili 1:1 - Profiles 1:1

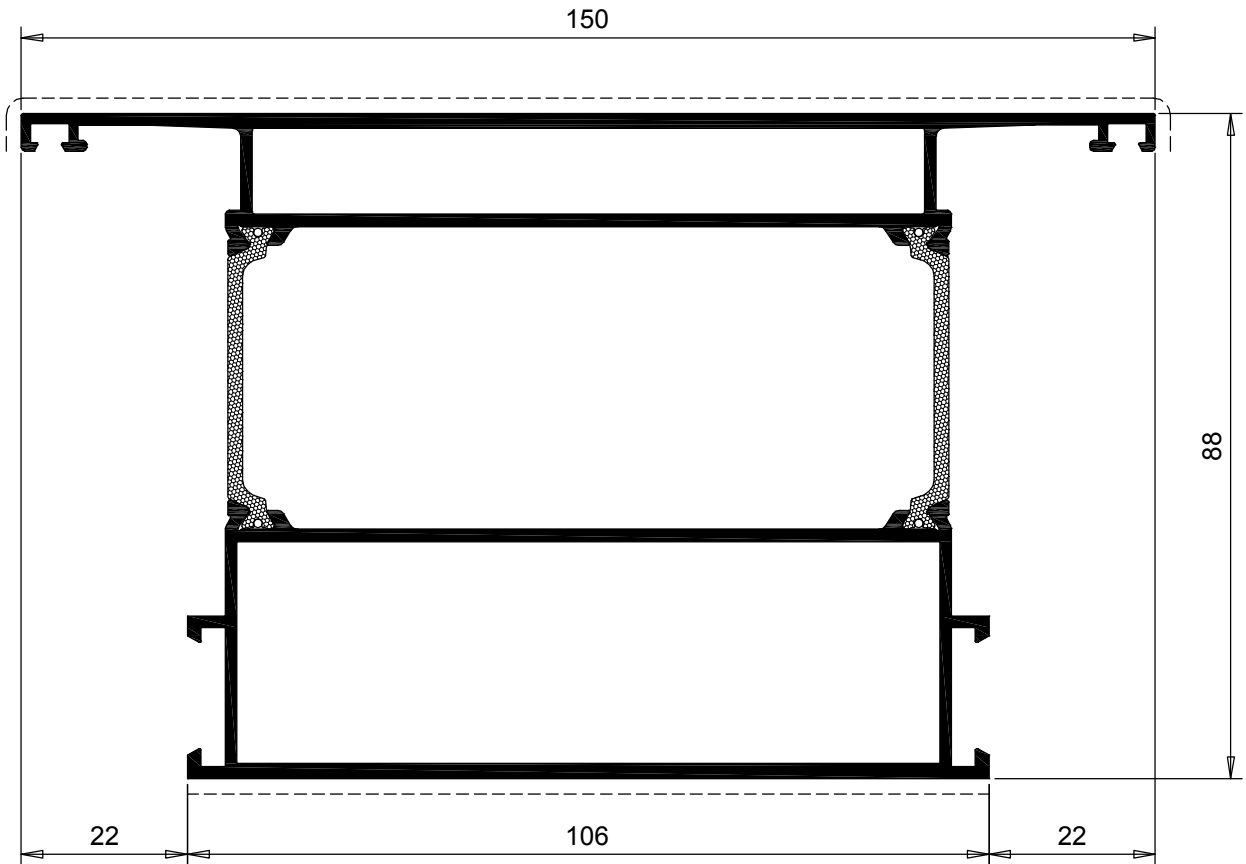

TT78-34	FASCIA DA 150 MM ANTE COMPLANARI			
	HORIZZONTAL TRANSOM 150 mm FOR COMPLANAR WINGS			
PESO WEIGHT	PERIMETRO PERIMETER	SUP. VISTA SHOWN SURF.	J _x	J _y
Kg/m	mm	mm	cm ⁴	cm ⁴
3.055	576	266	124.42	150.99

ACCESSORI / ACCESSORIES		
CAVALLOTTI / T-JOINT		
INT.	EXT.	
	ANTA / WING	TELAIO / FIXED FRAME
EA-0136	174-1591	-

Profili 1:1 - Profiles 1:1

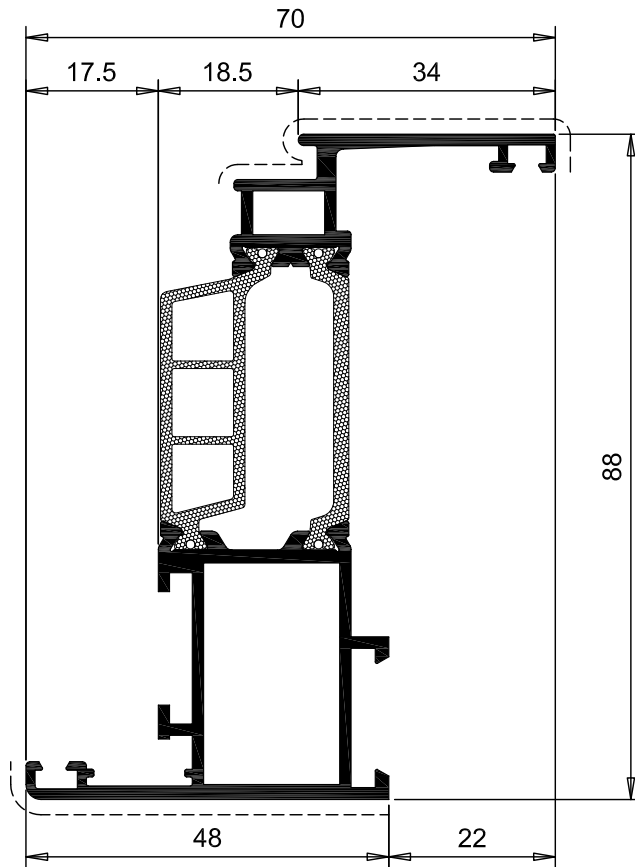

TT78-10	ANTA PICCOLA SMALL WING			
PESO WEIGHT	PERIMETRO PERIMETER	SUP. VISTA SHOWN SURF.	J _x	J _y
Kg/m	mm	mm	cm ⁴	cm ⁴
1.561	419	112	50.97	9.15

ACCESSORI / ACCESSORIES			
SQUADRETTE / CORNER JOINT			
INT.			EXT.
BOTTONE BUTTON	CIANFRINARE CALKING	SPINARE PINNING	CIANFRINARE CALKING
-	174-1802	174-1802	*153-0058
ALLINEAMENTO / ALIGNMENT		ANG. VAR. / ADJUST. CORNER	
INT.	EXT.	INT.	EXT.
153-040.4	174-1591	-	-

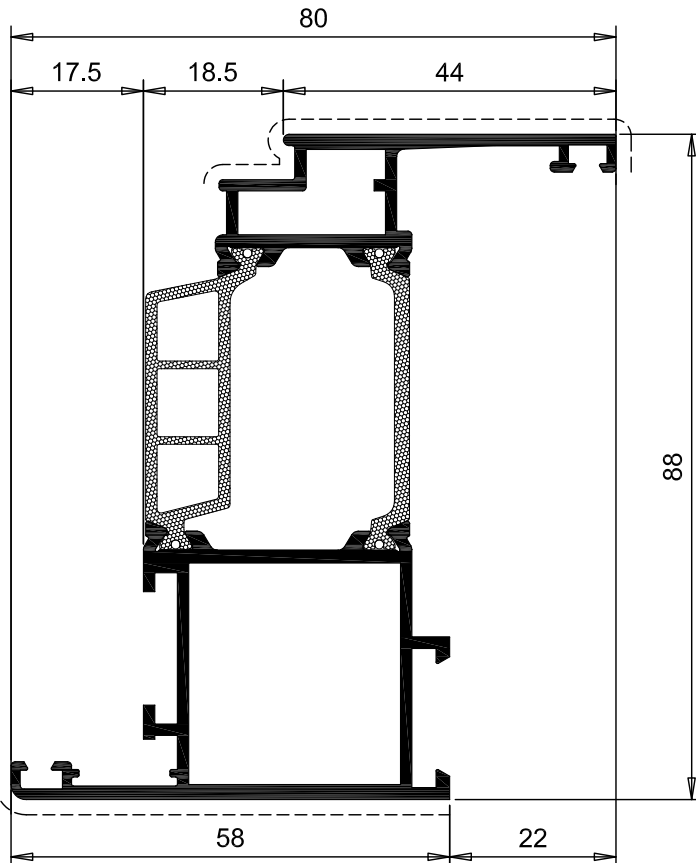

TT78-11	ANTA MEDIA MEDIUM WING			
PESO WEIGHT	PERIMETRO PERIMETER	SUP. VISTA SHOWN SURF.	J _x	J _y
Kg/m	mm	mm	cm ⁴	cm ⁴
1.780	436	129	61.43	15.60

ACCESSORI / ACCESSORIES			
SQUADRETTE / CORNER JOINT			
INT.			EXT.
BOTTONE BUTTON	CIANFRINARE CALKING	SPINARE PINNING	CIANFRINARE CALKING
-	174-1804	174-1804	*153-0060
ALLINEAMENTO / ALIGNMENT		ANG. VAR. / ADJUST. CORNER	
INT.	EXT.	INT.	EXT.
153-040.4	174-1591	-	-

Note: = profilo non a stock
profile no stock

Note: * = possibilità di fissaggio con grano art. 535-090.19
joint fixing available with hexagon socket set screw item 535-090.19

Profili 1:1 - Profiles 1:1

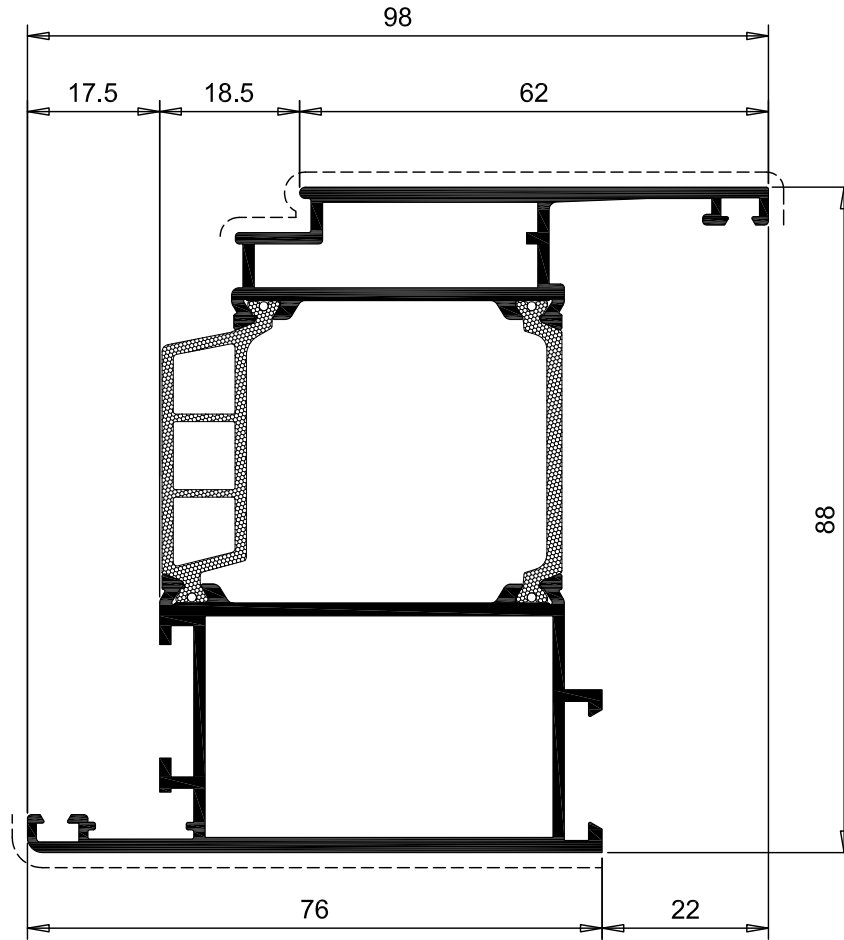

TT78-12	ANTA MAGGIORATA OVERSIZE WING			
PESO WEIGHT	PERIMETRO PERIMETER	SUP. VISTA SHOWN SURF.	J _x	J _y
Kg/m	mm	mm	cm ⁴	cm ⁴
2.139	472	165	78.20	34.45

ACCESSORI / ACCESSORIES			
SQUADRETTE / CORNER JOINT			
INT.			EXT.
BOTTONE BUTTON	CIANFRINARE CALKING	SPINARE PINNING	CIANFRINARE CALKING
-	174-1806	174-1806	*153-0062
ALLINEAMENTO / ALIGNMENT		ANG. VAR. / ADJUST. CORNER	
INT.	EXT.	INT.	EXT.
153-040.4	174-1591	-	-

Note: * = possibilità di fissaggio con grano art. 535-090.19
joint fixing available with hexagon socket set screw item 535-090.19

Profili 1:1 - Profiles 1:1

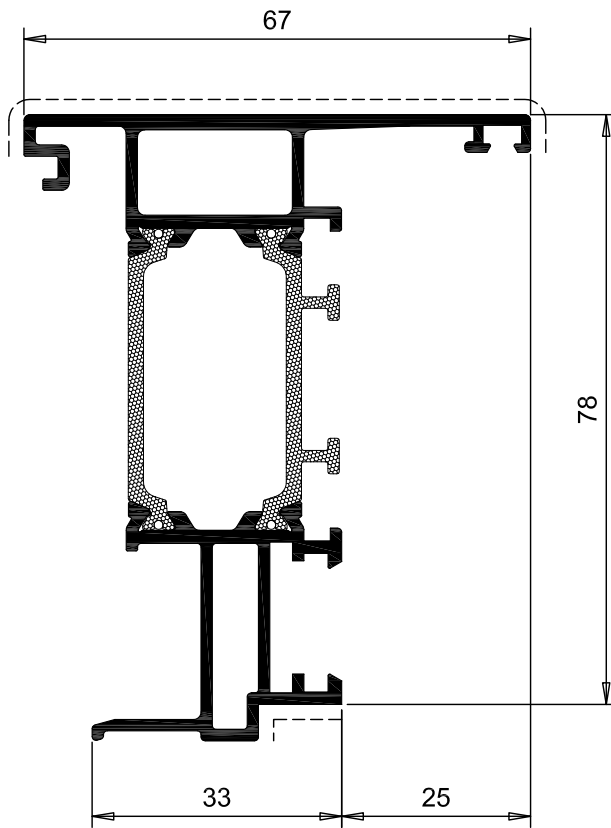

TT78-19	BATTUTA RIPORTATA CENTRAL RABBET			
PESO WEIGHT	PERIMETRO PERIMETER	SUP. VISTA SHOWN SURF.	J _x	J _y
Kg/m	mm	mm	cm ⁴	cm ⁴
1.568	442	93	46.23	9.37

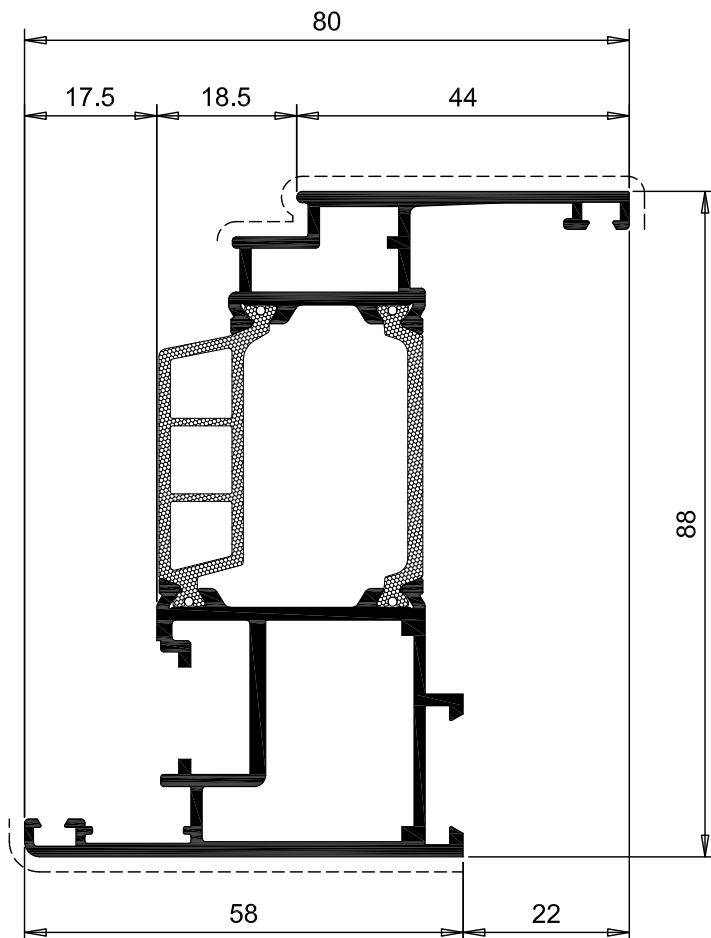

TT78-22	ANTA PER PISTA 16 EURO GROOVE 16 mm WING			
PESO WEIGHT	PERIMETRO PERIMETER	SUP. VISTA SHOWN SURF.	J _x	J _y
Kg/m	mm	mm	cm ⁴	cm ⁴
1.874	460	125	63.53	15.40

ACCESSORI / ACCESSORIES			
SQUADRETTE / CORNER JOINT			
INT.			EXT.
BOTTONE BUTTON	CIANFRINARE CALKING	SPINARE PINNING	CIANFRINARE CALKING
-	174-1802	174-1802	*153-0060
ALLINEAMENTO / ALIGNMENT		ANG. VAR. / ADJUST. CORNER	
INT.	EXT.	INT.	EXT.
153-040.4	174-1591	-	-

Note: * = possibilità di fissaggio con grano art. 535-090.19
joint fixing available with hexagon socket set screw item 535-090.19

Profili 1:1 - Profiles 1:1

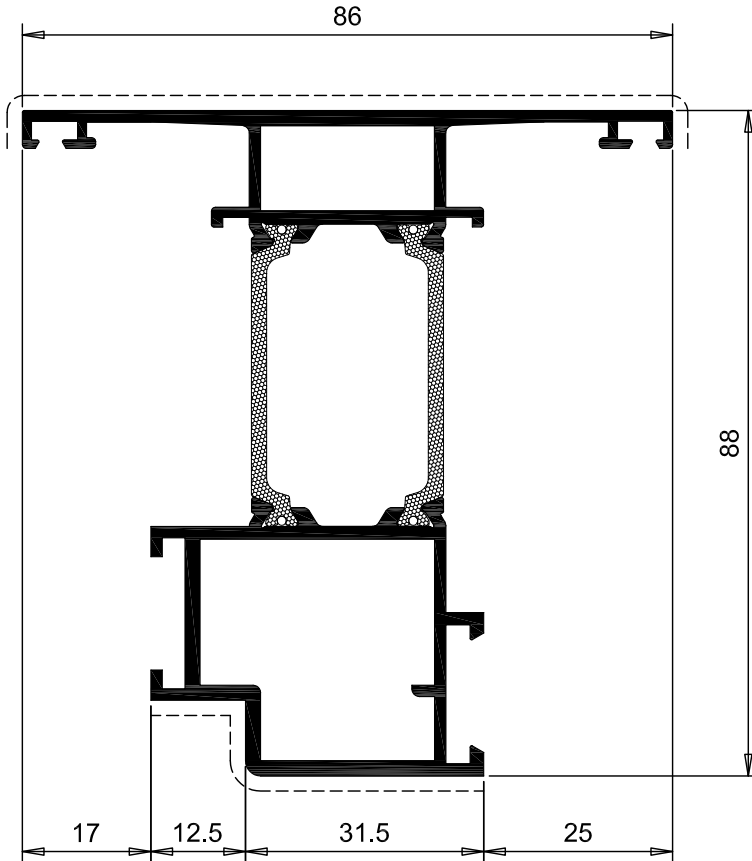

TT78-44	ANTA PER BILICO WING FOR PIVOTING WINDOW			
PESO WEIGHT	PERIMETRO PERIMETER	SUP. VISTA SHOWN SURF.	J _x	J _y
Kg/m	mm	mm	cm ⁴	cm ⁴
1.864	486	150	67.26	19.29

ACCESSORI / ACCESSORIES			
SQUADRETTE / CORNER JOINT			
INT.			EXT.
BOTTONE BUTTON	CIANFRINARE CALKING	SPINARE PINNING	CIANFRINARE CALKING
-	174-1805	174-1805	*153-0059
ALLINEAMENTO / ALIGNMENT		ANG. VAR. / ADJUST. CORNER	
INT.	EXT.	INT.	EXT.
-	174-1591	-	-

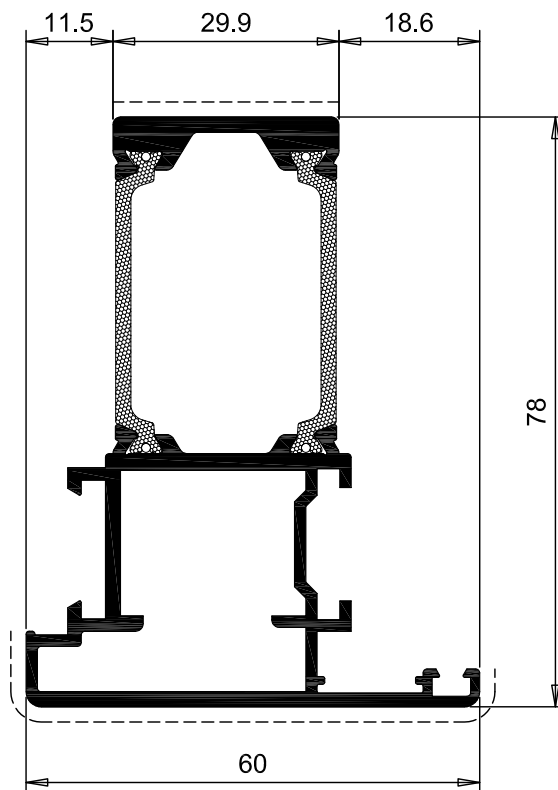

TT78-45	INVERSIONE DI BATTUTA PER BILICO INVERSION OF RABBET FOR PIVOTING WINDOW			
PESO WEIGHT	PERIMETRO PERIMETER	SUP. VISTA SHOWN SURF.	J _x	J _y
Kg/m	mm	mm	cm ⁴	cm ⁴
1.640	342	105	42.89	10.55

ACCESSORI / ACCESSORIES			
SQUADRETTE / CORNER JOINT			
INT.			EXT.
BOTTONE BUTTON	CIANFRINARE CALKING	SPINARE PINNING	CIANFRINARE CALKING
-	174-1803	174-1803	-
ALLINEAMENTO / ALIGNMENT		ANG. VAR. / ADJUST. CORNER	
INT.	EXT.	INT.	EXT.
153-040.4	-	-	-

Note: * = possibilità di fissaggio con grano art. 535-090.19
joint fixing available with hexagon socket set screw item 535-090.19

Profili 1:1 - Profiles 1:1

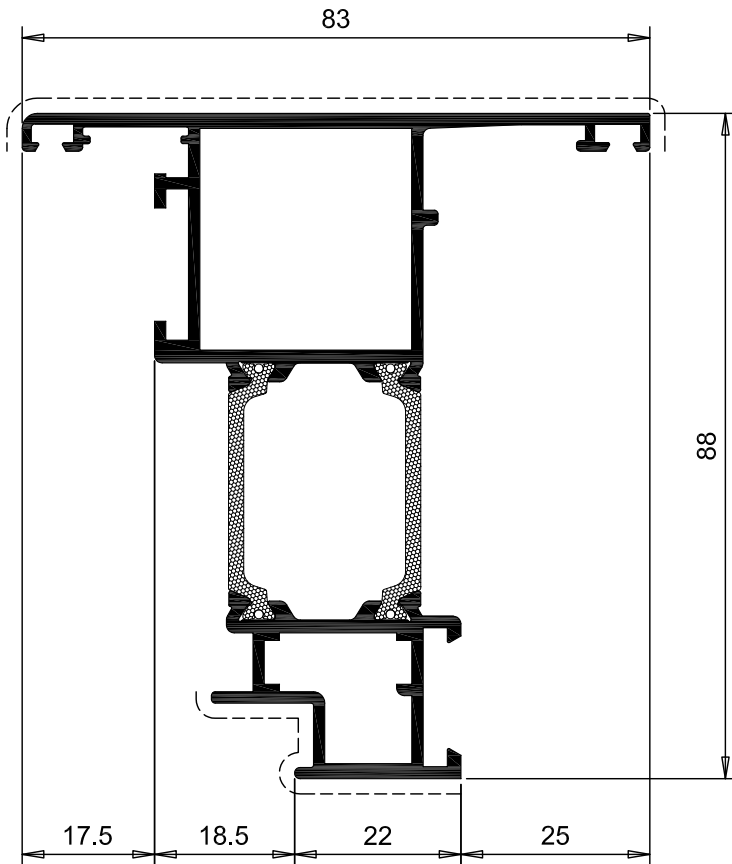

TT78-37			ANTA APERTURA ESTERNA EXTERNAL OPENING WING		Y X — X ↓	
PESO WEIGHT	PERIMETRO PERIMETER	SUP. VISTA SHOWN SURF.	J _x	J _y		
Kg/m	mm	mm	cm ⁴	cm ⁴		
1.768	456	142	58.79	16.75		

ACCESSORI / ACCESSORIES			
SQUADRETTE / CORNER JOINT			
INT.			EXT.
BOTTONE BUTTON	CIANFRINARE CALKING	SPINARE PINNING	CIANFRINARE CALKING
-	*153-0060	174-1804	174-1804
ALLINEAMENTO / ALIGNMENT		ANG. VAR. / ADJUST. CORNER	
INT.	EXT.	INT.	EXT.
153-040.4	174-1591	-	-

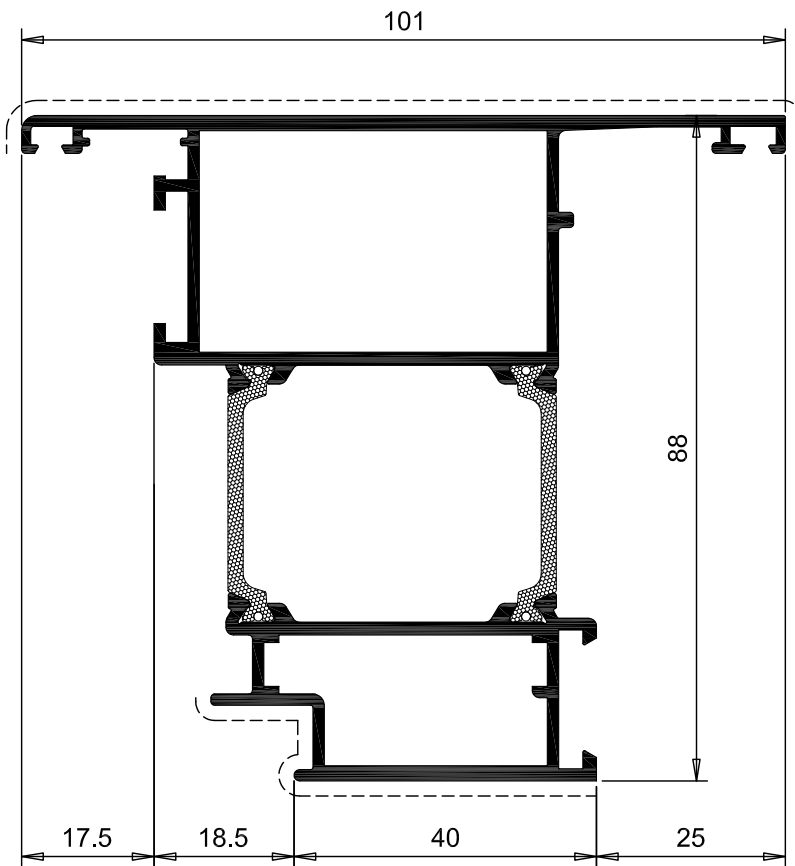

TT78-38			ANTA MAGGIORATA APERTURA ESTERNA OVERSIZE EXTERNAL OPENING WING		Y X — X ↓	
PESO WEIGHT	PERIMETRO PERIMETER	SUP. VISTA SHOWN SURF.	J _x	J _y		
Kg/m	mm	mm	cm ⁴	cm ⁴		
2.128	492	178	75.50	36.56		

ACCESSORI / ACCESSORIES			
SQUADRETTE / CORNER JOINT			
INT.			EXT.
BOTTONE BUTTON	CIANFRINARE CALKING	SPINARE PINNING	CIANFRINARE CALKING
-	*153-0062	174-1806	174-1806
ALLINEAMENTO / ALIGNMENT		ANG. VAR. / ADJUST. CORNER	
INT.	EXT.	INT.	EXT.
153-040.4	174-1591	-	-

Note:  = profilo non a stock
profile no stock

Note: * = possibilità di fissaggio con grano art. 535-090.19
joint fixing available with hexagon socket set screw item 535-090.19

Profili 1:1 - Profiles 1:1

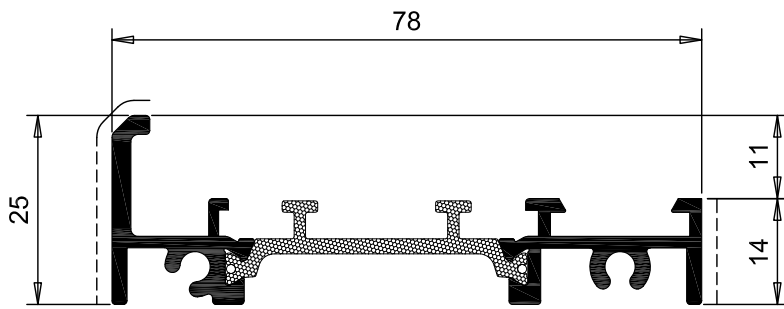

TT78-36	SOGLIA RIDOTTA SMALL THRESHOLD		$\begin{matrix} Y \\ X \rightarrow X \\ Y \end{matrix}$	
PESO WEIGHT	PERIMETRO PERIMETER	SUP. VISTA SHOWN SURF.	J _x	J _y
Kg/m	mm	mm	cm ⁴	cm ⁴
0.859	533	43	-	-

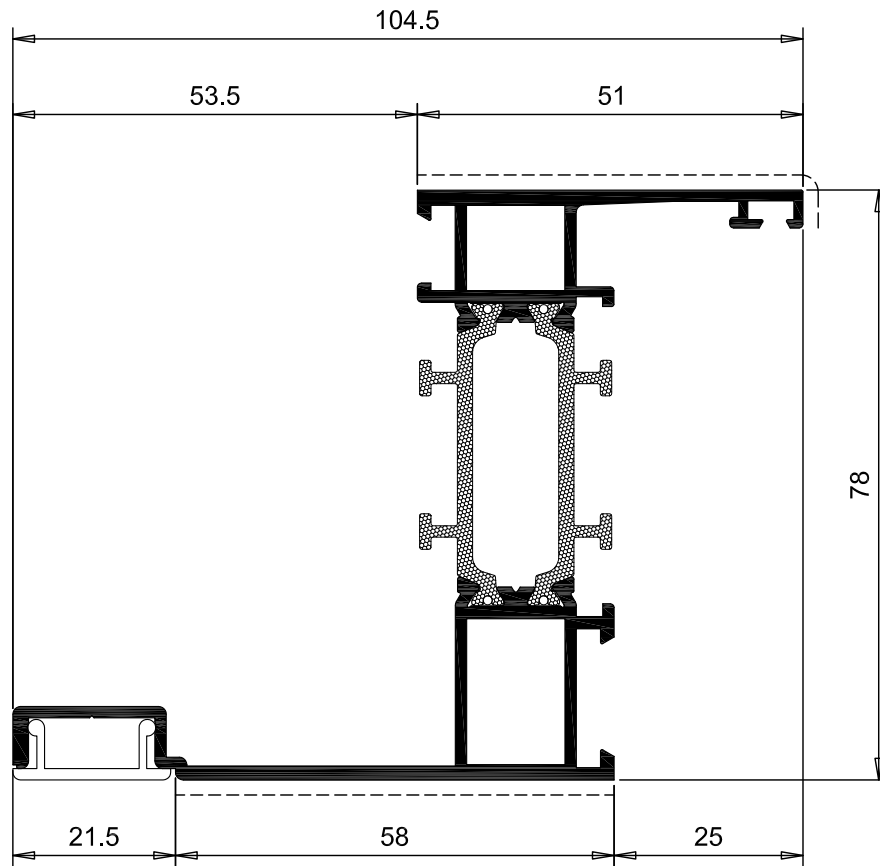

TT78-40	TELAIO FISSO Z PER RISTRUTTURAZIONE Z-FIXED FRAME		$\begin{matrix} Y \\ X \rightarrow X \\ Y \end{matrix}$	
PESO WEIGHT	PERIMETRO PERIMETER	SUP. VISTA SHOWN SURF.	J _x	J _y
Kg/m	mm	mm	cm ⁴	cm ⁴
1.654	543	114	49.87	27.06

ACCESSORI / ACCESSORIES			
SQUADRETTE / CORNER JOINT			
INT.		EXT.	
BOTTONE BUTTON	CIANFRINARE CALKING	SPINARE PINNING	CIANFRINARE CALKING
-	174-1801	174-1801	*153-0057
ALLINEAMENTO / ALIGNMENT		ANG. VAR. / ADJUST. CORNER	
INT.	EXT.	INT.	EXT.
-	174-1591	-	-

Note:  = profilo non a stock
profile no stock

Note: * = possibilità di fissaggio con grano art. 535-090.19
joint fixing available with hexagon socket set screw item 535-090.19

Profili 1:1 - Profiles 1:1

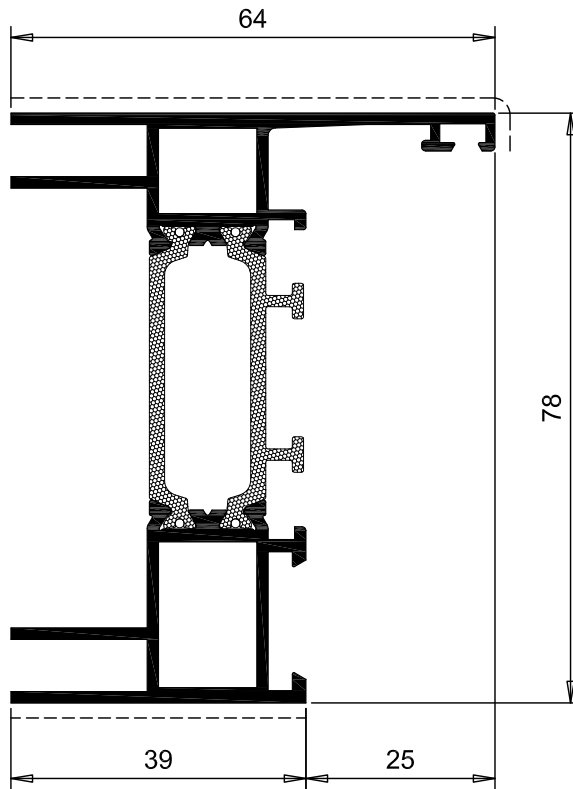

TT78-46	TELAIO PER GIUNTO FRAME FOR JOINT			
PESO WEIGHT	PERIMETRO PERIMETER	SUP. VISTA SHOWN SURF.	J _x	J _y
Kg/m	mm	mm	cm ⁴	cm ⁴
1.522	456	108	44.73	8.84

ACCESSORI / ACCESSORIES			
SQUADRETTE / CORNER JOINT			
INT.		EXT.	
BOTTONE BUTTON	CIANFRINARE CALKING	SPINARE PINNING	CIANFRINARE CALKING
-	174-1801	174-1801	*153-0057
ALLINEAMENTO / ALIGNMENT		ANG. VAR. / ADJUST. CORNER	
INT.	EXT.	INT.	EXT.
-	174-1591	-	-

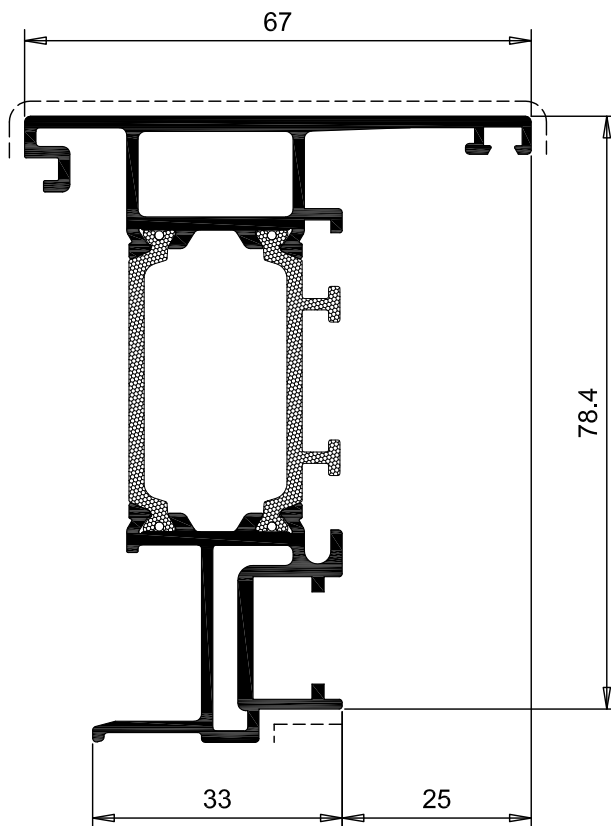

TT78-25	BATTUTA RIPORTATA PER PISTA 16 EURO GROOVE 16 mm CENTRAL RABBET			
PESO WEIGHT	PERIMETRO PERIMETER	SUP. VISTA SHOWN SURF.	J _x	J _y
Kg/m	mm	mm	cm ⁴	cm ⁴
1.614	441	93	47.49	9.39

Note: = profilo non a stock
profile no stock

Note: * = possibilità di fissaggio con grano art. 535-090.19
joint fixing available with hexagon socket set screw item 535-090.19

Profili 1:1 - Profiles 1:1

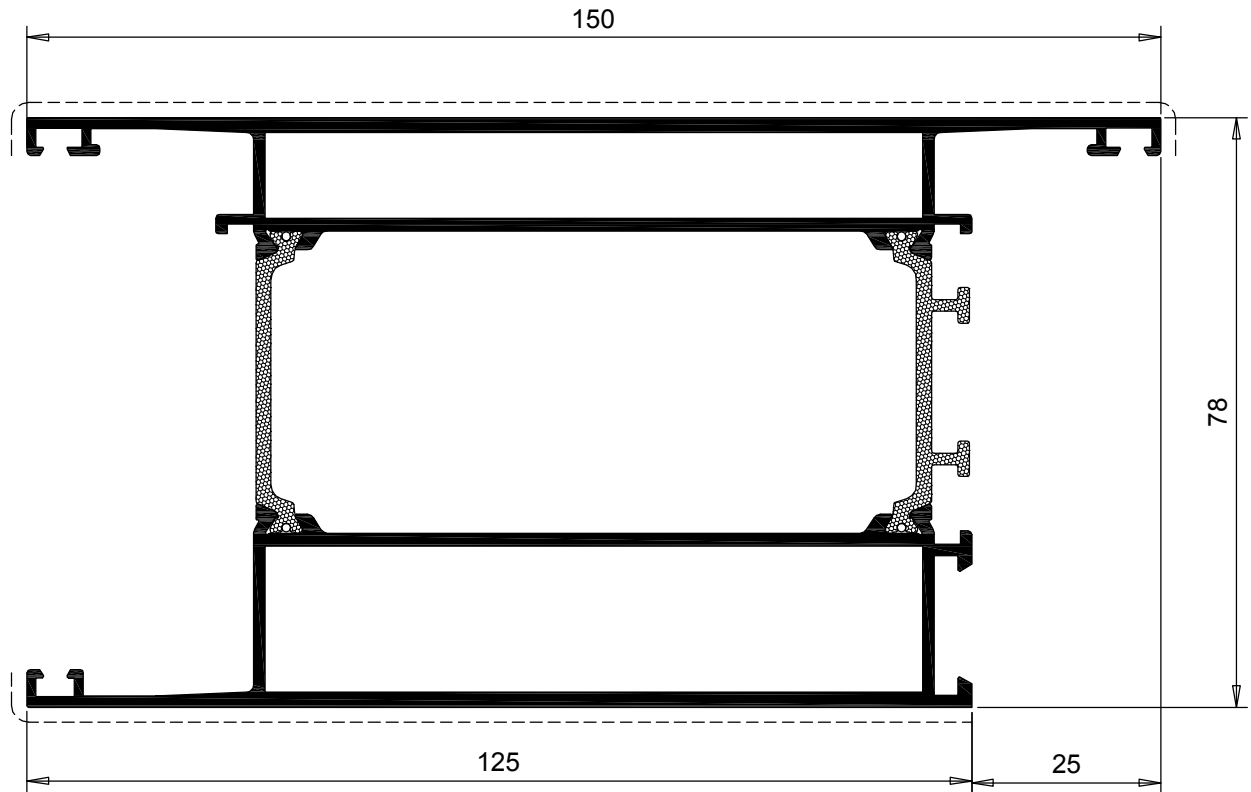

TT78-47	ZOCOLO DA 150 MM PER TELAI FISSI LOWER TRANSOM 150 MM FOR FIXED FRAMES			
	PESO WEIGHT	PERIMETRO PERIMETER	SUP. VISTA SHOWN SURF.	J _x
Kg/m	mm	mm	cm ⁴	cm ⁴
3.069	629	290	101.07	153.47

ACCESSORI / ACCESSORIES		
CAVALLOTTI / T-JOINT		
INT.	EXT.	
	ANTA / WING	TELAIO / FIXED FRAME
EA-0135	EA-0032	174-1591+EA-0139

Profili 1:1 - Profiles 1:1

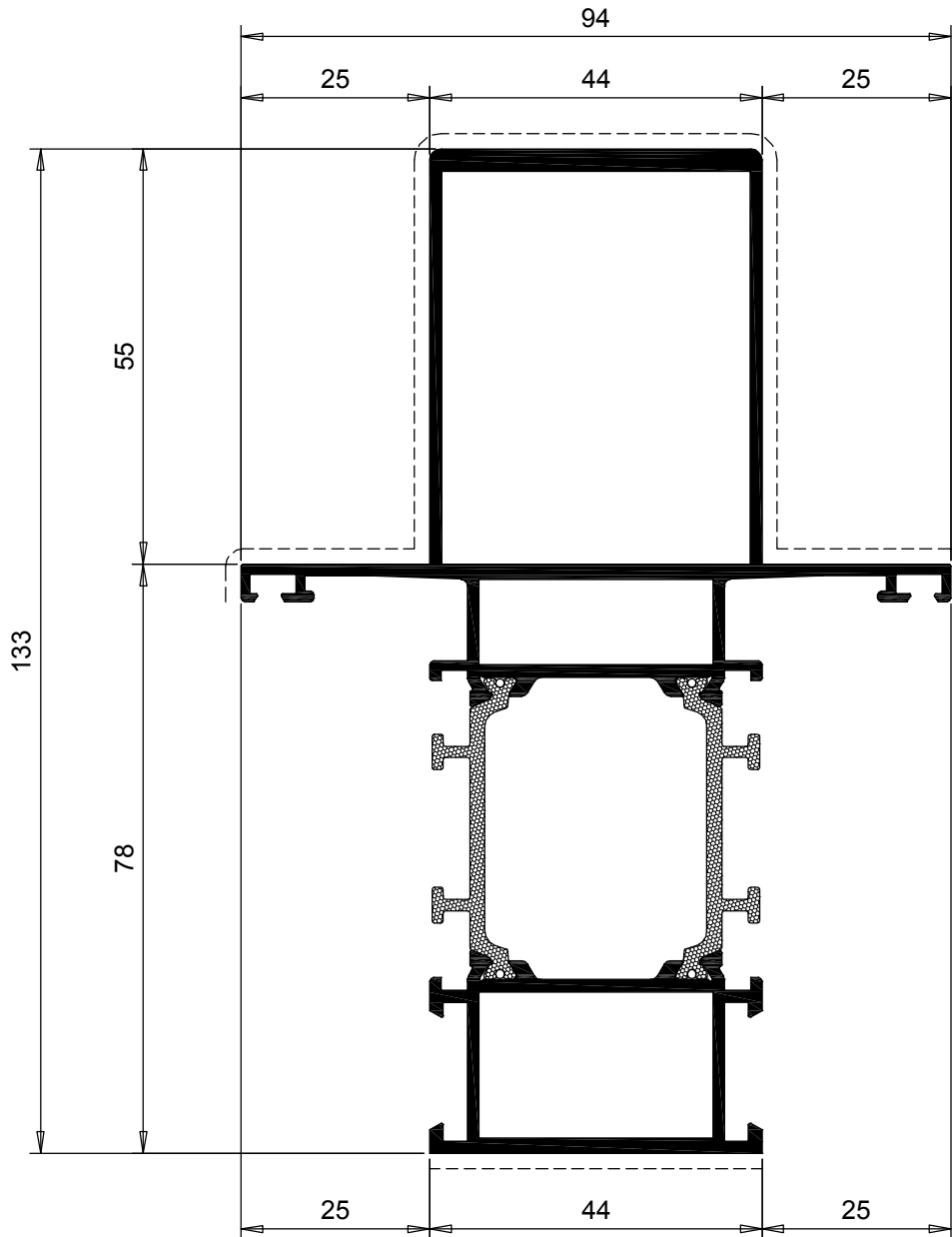

TT78-48	PILASTRINO MULLION			
	PESO WEIGHT	PERIMETRO PERIMETER	SUP. VISTA SHOWN SURF.	J _x
Kg/m	mm	mm	cm ⁴	cm ⁴
2.694	580	203	162.97	32.72

ACCESSORI / ACCESSORIES		
CAVALLOTTI / T-JOINT		
INT.	EXT.	
	ANTA / WING	TELAIO / FIXED FRAME
-	-	174-1591

Profili 1:1 - Profiles 1:1

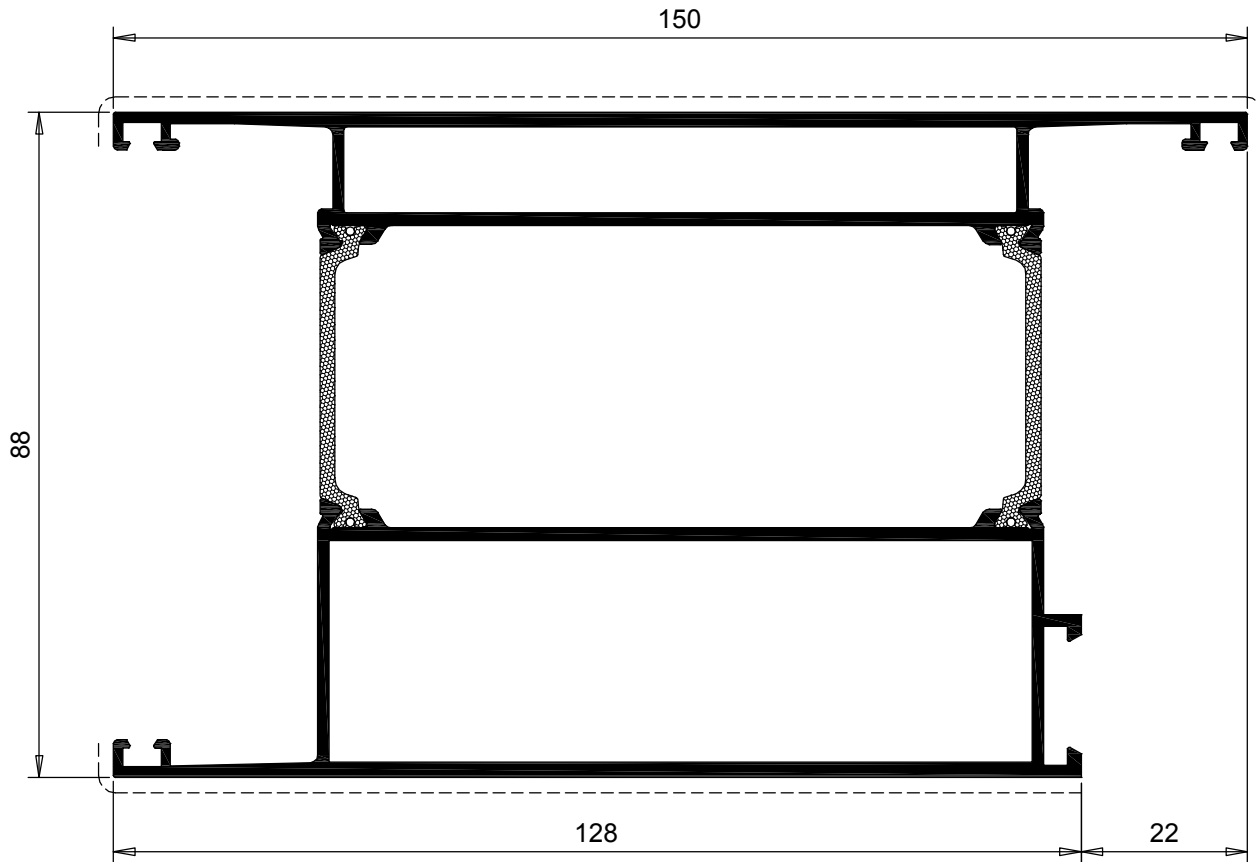

TT78-50	ZOCOLO DA 150 MM PER ANTE COMPLANARI LOWER TRANSOM 150 MM FOR COMPLANAR WINGS			
	PESO WEIGHT	PERIMETRO PERIMETER	SUP. VISTA SHOWN SURF.	J _x
Kg/m	mm	mm	cm ⁴	cm ⁴
3.145	618	288	129.45	169.44

ACCESSORI / ACCESSORIES		
CAVALLOTTI / T-JOINT		
INT.	EXT.	
	ANTA / WING	TELAIO / FIXED FRAME
EA-0136	174-1591	-

Profili 1:1 - Profiles 1:1

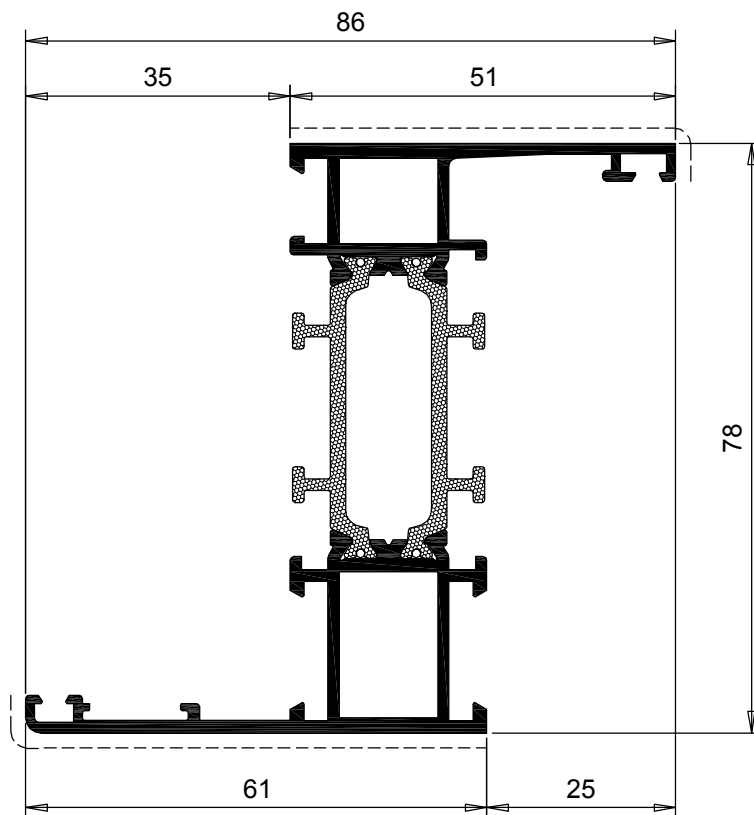

TT78-51	TELAIO FISSO Z PICCOLO BATTUTA 35 mm		Y X — X Y	
	SMALL Z-FIXED FRAME 35 mm			
PESO WEIGHT	PERIMETRO PERIMETER	SUP. VISTA SHOWN SURF.	J _x	J _y
Kg/m	mm	mm	cm ⁴	cm ⁴
1.585	461	122	51.89	9.85

ACCESSORI / ACCESSORIES			
SQUADRETTE / CORNER JOINT			
INT.			EXT.
BOTTONE BUTTON	CIANFRINARE CALKING	SPINARE PINNING	CIANFRINARE CALKING
-	174-1801	174-1801	*153-0057
ALLINEAMENTO / ALIGNMENT		ANG. VAR. / ADJUST. CORNER	
INT.	EXT.	INT.	EXT.
153-040.4	174-1591	-	-

Note: * = possibilità di fissaggio con grano art. 535-090.19
joint fixing available with hexagon socket set screw item 535-090.19

Profili 1:1 - Profiles 1:1

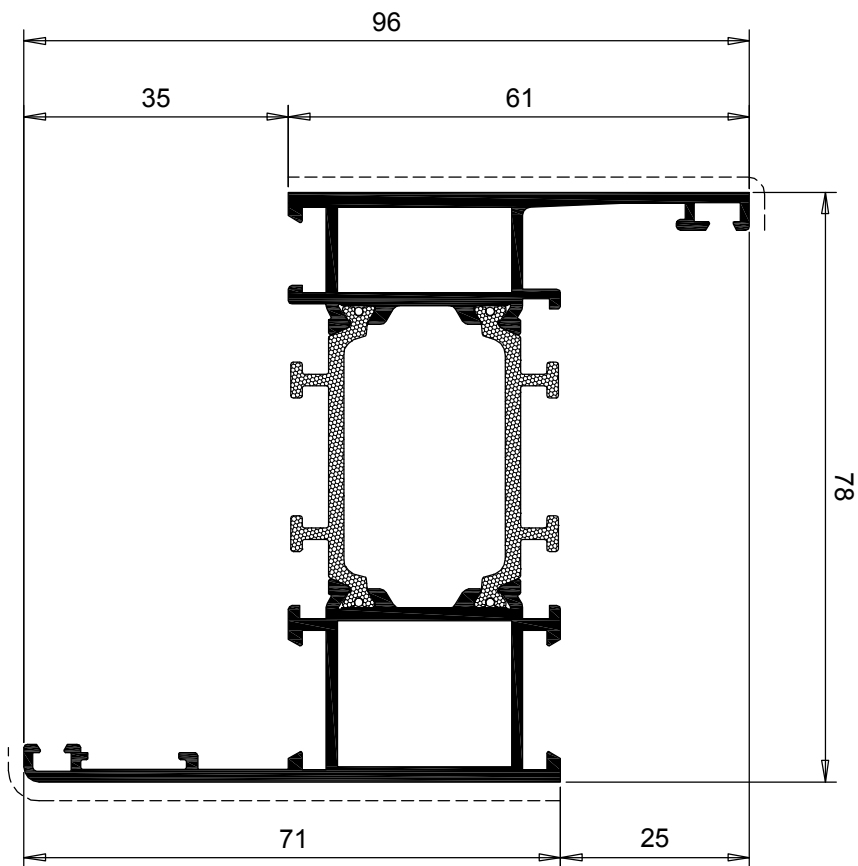

TT78-52	TELAIO FISSO Z MEDIO BATTUTA 35 mm MEDIUM FIXED FRAME 35 mm		Y X — X ↓	
	PESO WEIGHT	PERIMETRO PERIMETER	SUP. VISTA SHOWN SURF.	J _x J _y
Kg/m	mm	mm	cm ⁴ cm ⁴	
1.800	480	142	60.93 15.00	

ACCESSORI / ACCESSORIES			
SQUADRETTE / CORNER JOINT			
INT.			EXT.
BOTTONE BUTTON	CIANFRINARE CALKING	SPINARE PINNING	CIANFRINARE CALKING
-	174-1803	174-1803	*153-0059
ALLINEAMENTO / ALIGNMENT		ANG. VAR. / ADJUST. CORNER	
INT.	EXT.	INT.	EXT.
153-040.4	174-1591	-	-

Note: * = possibilità di fissaggio con grano art. 535-090.19
joint fixing available with hexagon socket set screw item 535-090.19

Profili 1:1 - Profiles 1:1

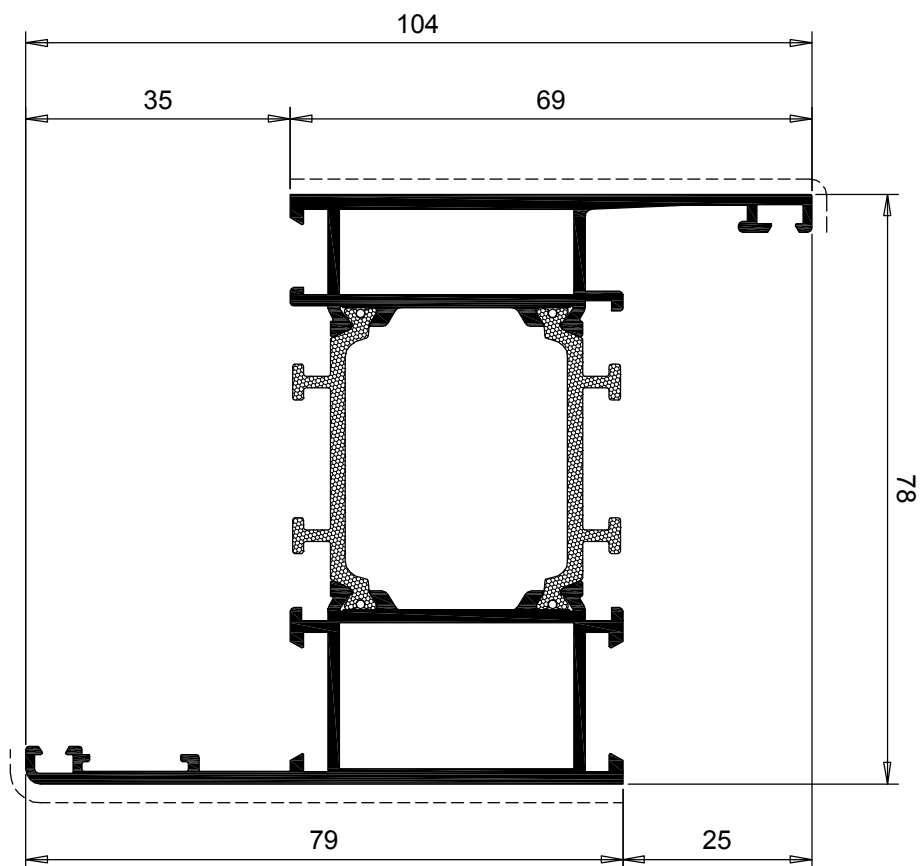

TT78-53	TELAIO FISSO Z GRANDE BATTUTA 35 mm OVERSIZE FIXED FRAME 35 mm			
	PESO WEIGHT	PERIMETRO PERIMETER	SUP. VISTA SHOWN SURF.	J _x J _y
Kg/m	mm	mm	cm ⁴ cm ⁴	
1.958	496	158	68.41 21.29	

ACCESSORI / ACCESSORIES			
SQUADRETTE / CORNER JOINT			
INT.			EXT.
BOTTONE BUTTON	CIANFRINARE CALKING	SPINARE PINNING	CIANFRINARE CALKING
-	174-1805	174-1805	*153-0061
ALLINEAMENTO / ALIGNMENT		ANG. VAR. / ADJUST. CORNER	
INT.	EXT.	INT.	EXT.
153-040.4	174-1591	-	-

Note: * = possibilità di fissaggio con grano art. 535-090.19
joint fixing available with hexagon socket set screw item 535-090.19

Profili 1:1 - Profiles 1:1

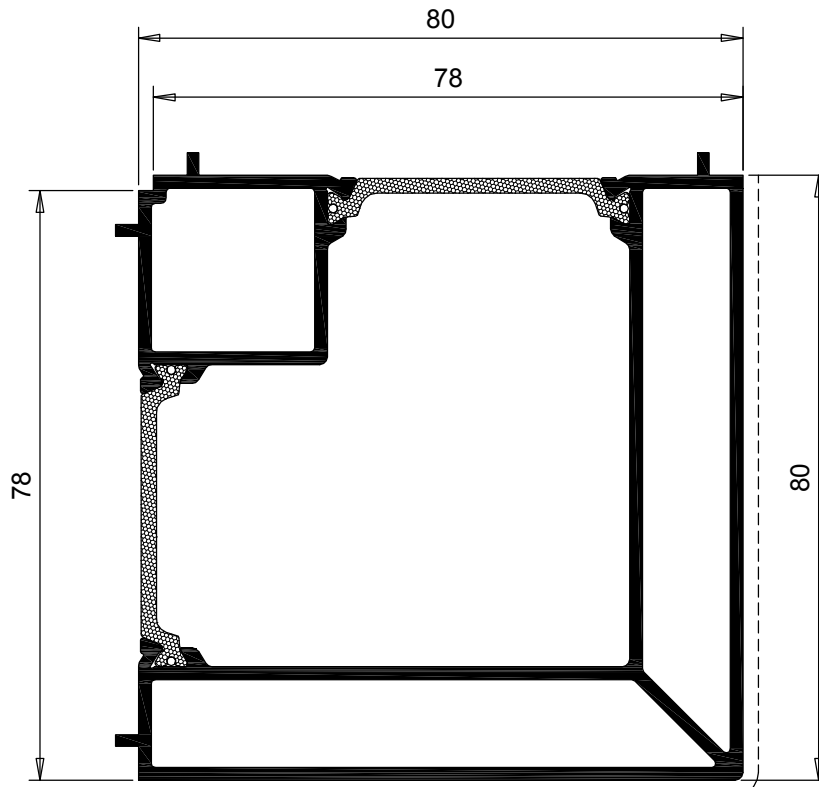

TT78-41			MONTANTE D'ANGOLO CORNER JAMB			
PESO WEIGHT	PERIMETRO PERIMETER	SUP. VISTA SHOWN SURF.	J _x	J _y		
Kg/m	mm	mm	cm ⁴	cm ⁴		
2.383	345	166	72.08	72.08		

Note:  = profilo non a stock
profile no stock

Profili 1:1 - Profiles 1:1

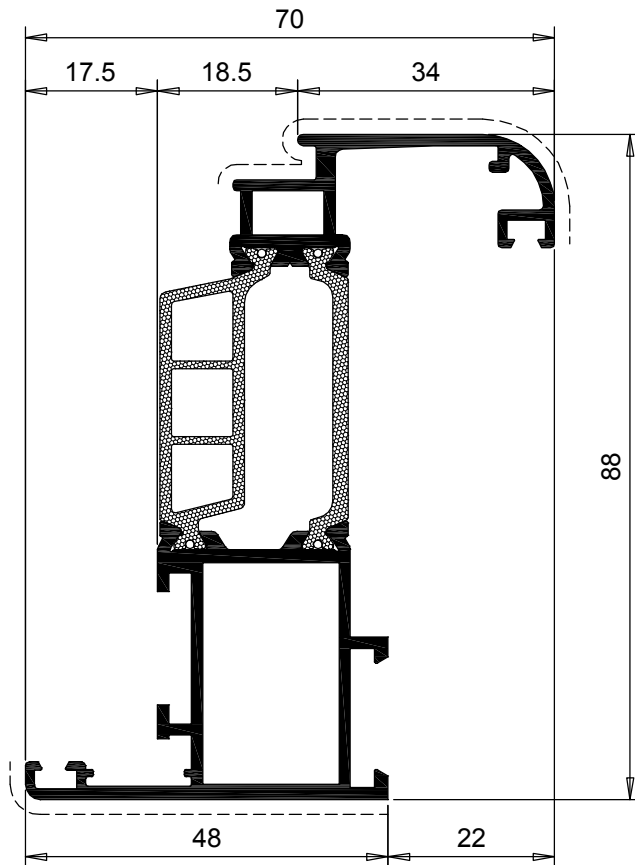

TT78-16	ANTA PICCOLA STONDATA SMALL ROUNDED WING		$\begin{matrix} Y \\ X \text{---} X \\ Y \end{matrix}$	
	PESO WEIGHT Kg/m	PERIMETRO PERIMETER mm	SUP. VISTA SHOWN SURF. mm	$\begin{matrix} J_x & J_y \\ \text{cm}^4 & \text{cm}^4 \end{matrix}$
1.623	441	116	57.83	7.05

ACCESSORI / ACCESSORIES			
SQUADRETTE / CORNER JOINT			
INT.		EXT.	
BOTTONE BUTTON	CIANFRINARE CALKING	SPINARE PINNING	CIANFRINARE CALKING
-	174-1802	174-1802	*153-0058
ALLINEAMENTO / ALIGNMENT		ANG. VAR. / ADJUST. CORNER	
INT.	EXT.	INT.	EXT.
153-040.4	174-1591	-	-

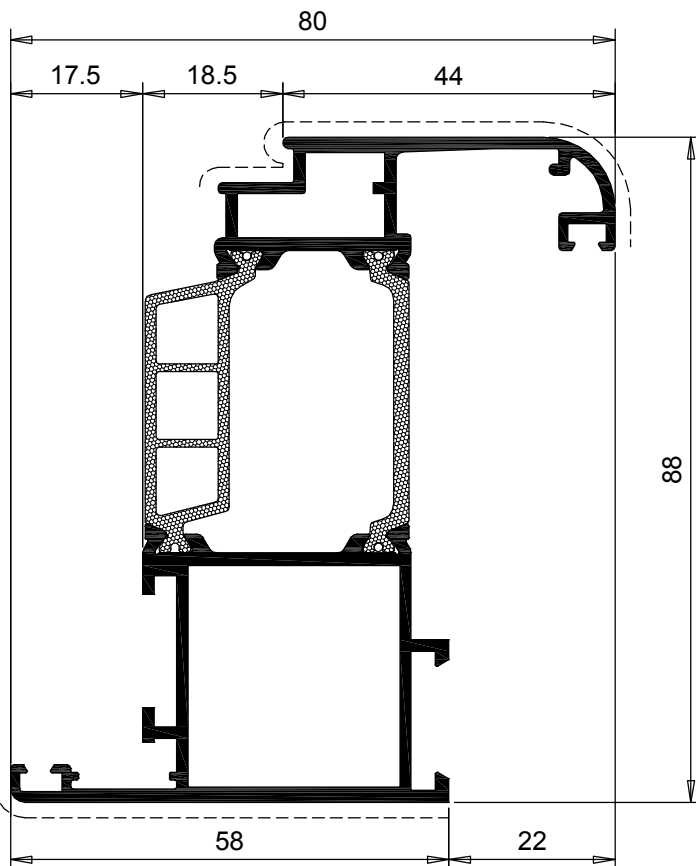

TT78-17	ANTA MEDIA STONDATA MEDIUM ROUNDED WING		$\begin{matrix} Y \\ X \text{---} X \\ Y \end{matrix}$	
	PESO WEIGHT Kg/m	PERIMETRO PERIMETER mm	SUP. VISTA SHOWN SURF. mm	$\begin{matrix} J_x & J_y \\ \text{cm}^4 & \text{cm}^4 \end{matrix}$
1.842	459	135	69.65	12.83

ACCESSORI / ACCESSORIES			
SQUADRETTE / CORNER JOINT			
INT.		EXT.	
BOTTONE BUTTON	CIANFRINARE CALKING	SPINARE PINNING	CIANFRINARE CALKING
-	174-1804	174-1804	*153-0060
ALLINEAMENTO / ALIGNMENT		ANG. VAR. / ADJUST. CORNER	
INT.	EXT.	INT.	EXT.
153-040.4	174-1591	-	-

Note: = profilo non a stock
profile no stock

Note: * = possibilità di fissaggio con grano art. 535-090.19
joint fixing available with hexagon socket set screw item 535-090.19

Profili 1:1 - Profiles 1:1

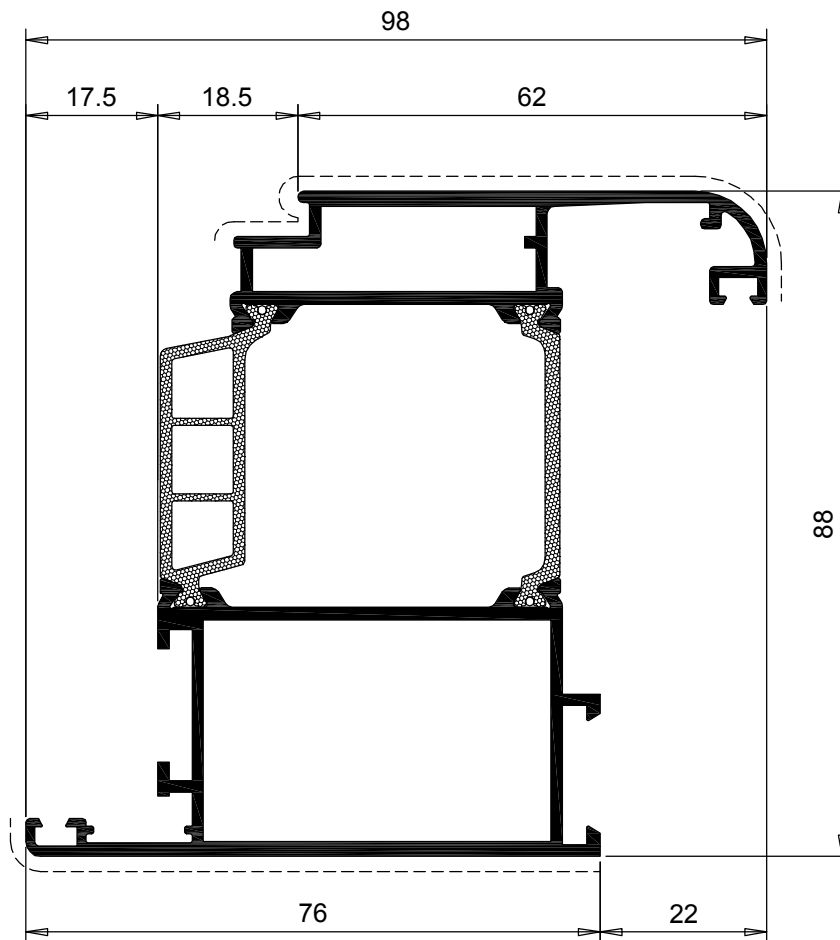

TT78-18	ANTA MAGGIORATA STONDATA OVERSIZE ROUNDED WING			
	PESO WEIGHT	PERIMETRO PERIMETER	SUP. VISTA SHOWN SURF.	J _x J _y
	Kg/m	mm	mm	cm ⁴ cm ⁴
	2.200	495	171	90.31 29.28

ACCESSORI / ACCESSORIES			
SQUADRETTE / CORNER JOINT			
INT.			EXT.
BOTTONE BUTTON	CIANFRINARE CALKING	SPINARE PINNING	CIANFRINARE CALKING
-	174-1806	174-1806	*153-0062
ALLINEAMENTO / ALIGNMENT		ANG. VAR. / ADJUST. CORNER	
INT.	EXT.	INT.	EXT.
153-040.4	174-1591	-	-

Note: * = possibilità di fissaggio con grano art. 535-090.19
joint fixing available with hexagon socket set screw item 535-090.19

Profili 1:1 - Profiles 1:1

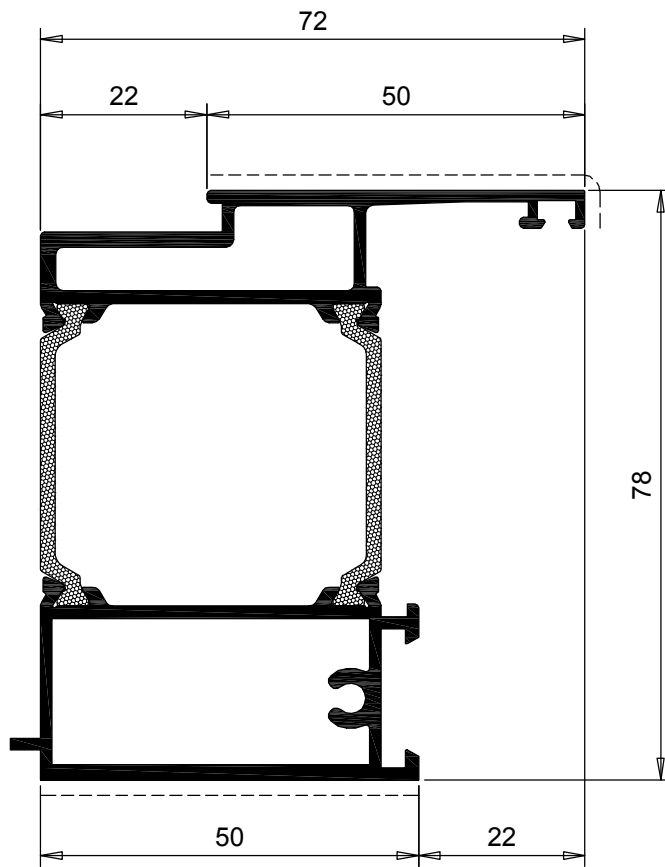

TT78-54	ZOCOLO RIPORTATO PER ANTE SAGOMATE/STONDATE		Y X—X Y	
	LOWER ADDITIONAL TRANSOM FOR SHAPED/ROUNDED WINGS			
PESO WEIGHT	PERIMETRO PERIMETER	SUP. VISTA SHOWN SURF.	J _x	J _y
Kg/m	mm	mm	cm ⁴	cm ⁴
1.855	366	105	54.07	21.21

ACCESSORI / ACCESSORIES		
CAVALLOTTI / T-JOINT		
INT.	EXT.	
	ANTA / WING	TELAIO / FIXED FRAME
-	-	174-1591

Note:  = profilo non a stock
profile no stock

Profili 1:1 - Profiles 1:1

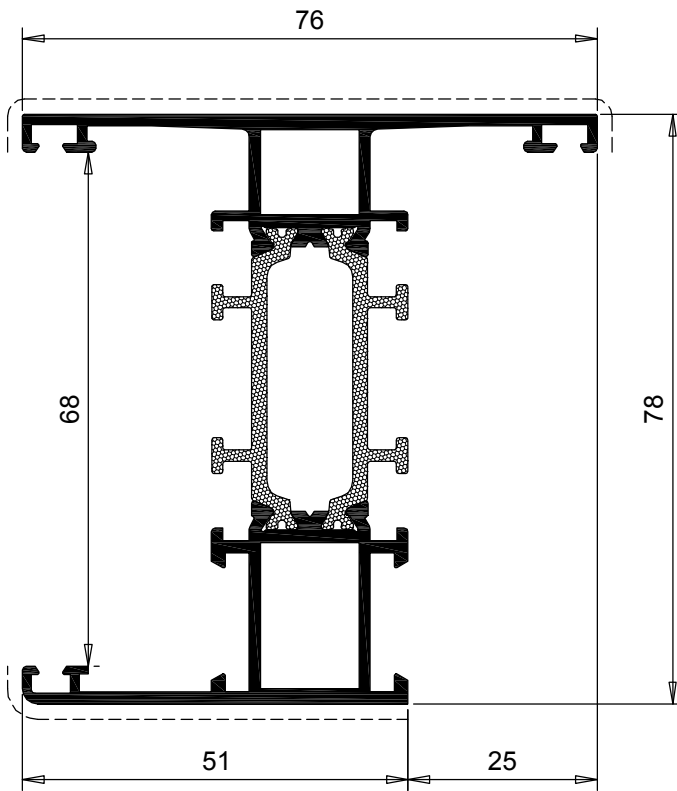

TT78-62		TELAIO FISSO H PICCOLO SMALL H-FIXED FRAME		Y X—X Y	
PESO WEIGHT	PERIMETRO PERIMETER	SUP. VISTA SHOWN SURF.	J _x	J _y	
Kg/m	mm	mm	cm ⁴	cm ⁴	
1.650	567	142	50.25	13.44	

ACCESSORI / ACCESSORIES

SQUADRETTE / CORNER JOINT

INT.				EXT.	
BOTTONE BUTTON	CIANFRINARE CALKING	SPINARE PINNING	CIANFRINARE CALKING		
-	174-1801	174-1801	*153-0057		
ALLINEAMENTO / ALIGNMENT		ANG. VAR. / ADJUST. CORNER			
INT.	EXT.	INT.	EXT.		
-	174-1591	-	-		

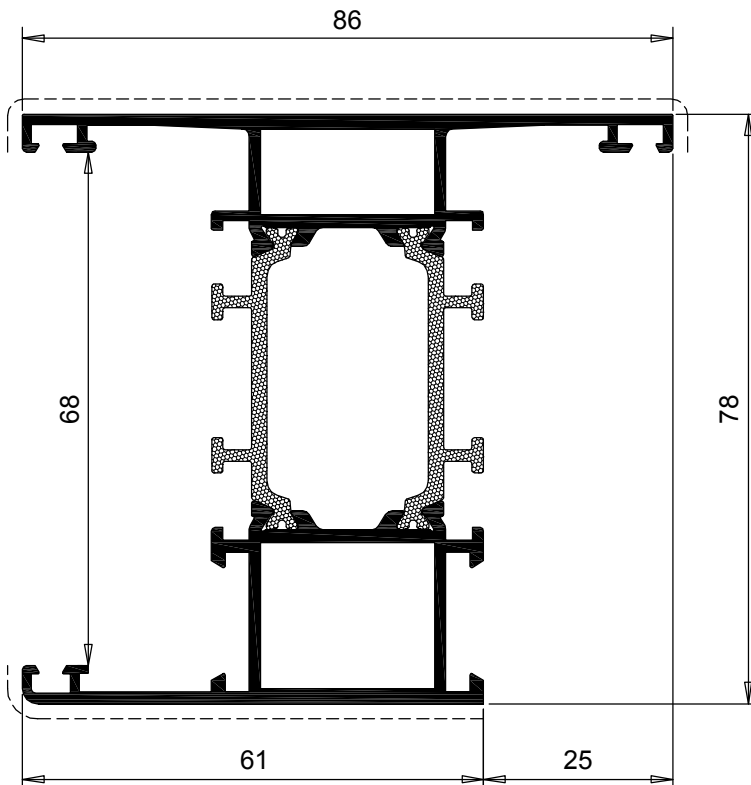

TT78-63		TELAIO FISSO H MEDIO MEDIUM H-FIXED FRAME		Y X—X Y	
PESO WEIGHT	PERIMETRO PERIMETER	SUP. VISTA SHOWN SURF.	J _x	J _y	
Kg/m	mm	mm	cm ⁴	cm ⁴	
1.684	587	162	57.75	21.16	

ACCESSORI / ACCESSORIES

SQUADRETTE / CORNER JOINT

INT.				EXT.	
BOTTONE BUTTON	CIANFRINARE CALKING	SPINARE PINNING	CIANFRINARE CALKING		
-	174-1803	174-1803	*153-0059		
ALLINEAMENTO / ALIGNMENT		ANG. VAR. / ADJUST. CORNER			
INT.	EXT.	INT.	EXT.		
-	174-1591	-	-		

Note:  = profilo non a stock
profile no stock

Note: * = possibilità di fissaggio con grano art. 535-090.19
joint fixing available with hexagon socket set screw item 535-090.19

Profili 1:1 - Profiles 1:1

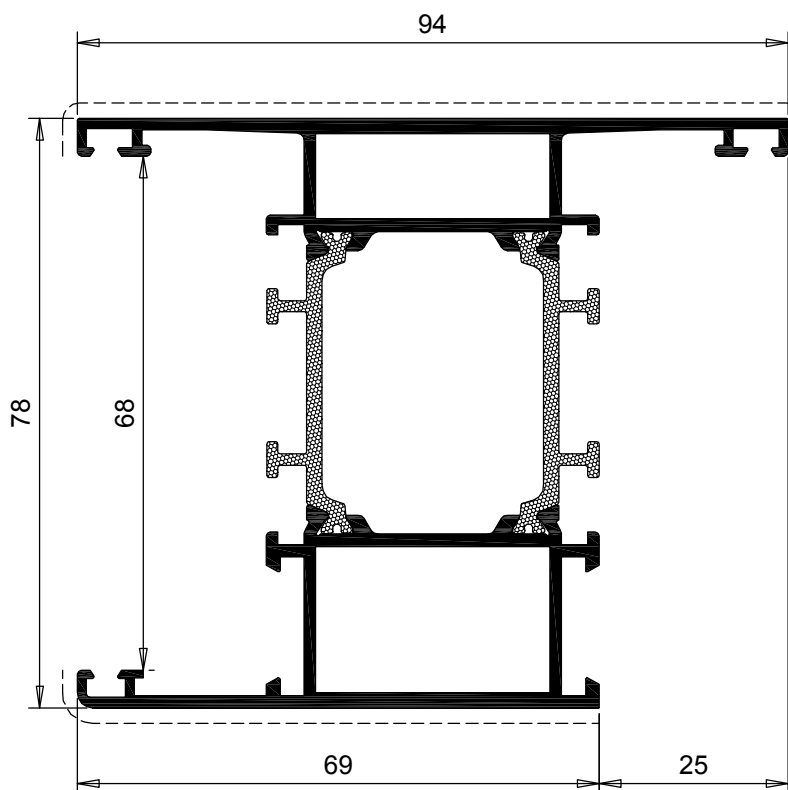

TT78-64	TELAIO FISSO H MAGGIORATO OVERSIZE H-FIXED FRAME			
	PESO WEIGHT	PERIMETRO PERIMETER	SUP. VISTA SHOWN SURF.	J _x J _y
	Kg/m	mm	mm	cm ⁴ cm ⁴
	2.024	603	178	63.58 29.53

ACCESSORI / ACCESSORIES			
SQUADRETTE / CORNER JOINT			
INT.		EXT.	
BOTTONE BUTTON	CIANFRINARE CALKING	SPINARE PINNING	CIANFRINARE CALKING
-	174-1805	174-1805	*153-0061
ALLINEAMENTO / ALIGNMENT		ANG. VAR. / ADJUST. CORNER	
INT.	EXT.	INT.	EXT.
-	174-1591	-	-

Note: = profilo non a stock
profile no stock

Note: * = possibilità di fissaggio con grano art. 535-090.19
joint fixing available with hexagon socket set screw item 535-090.19

Profili (NON IN SCALA) - Profiles (NOT IN SCALE)

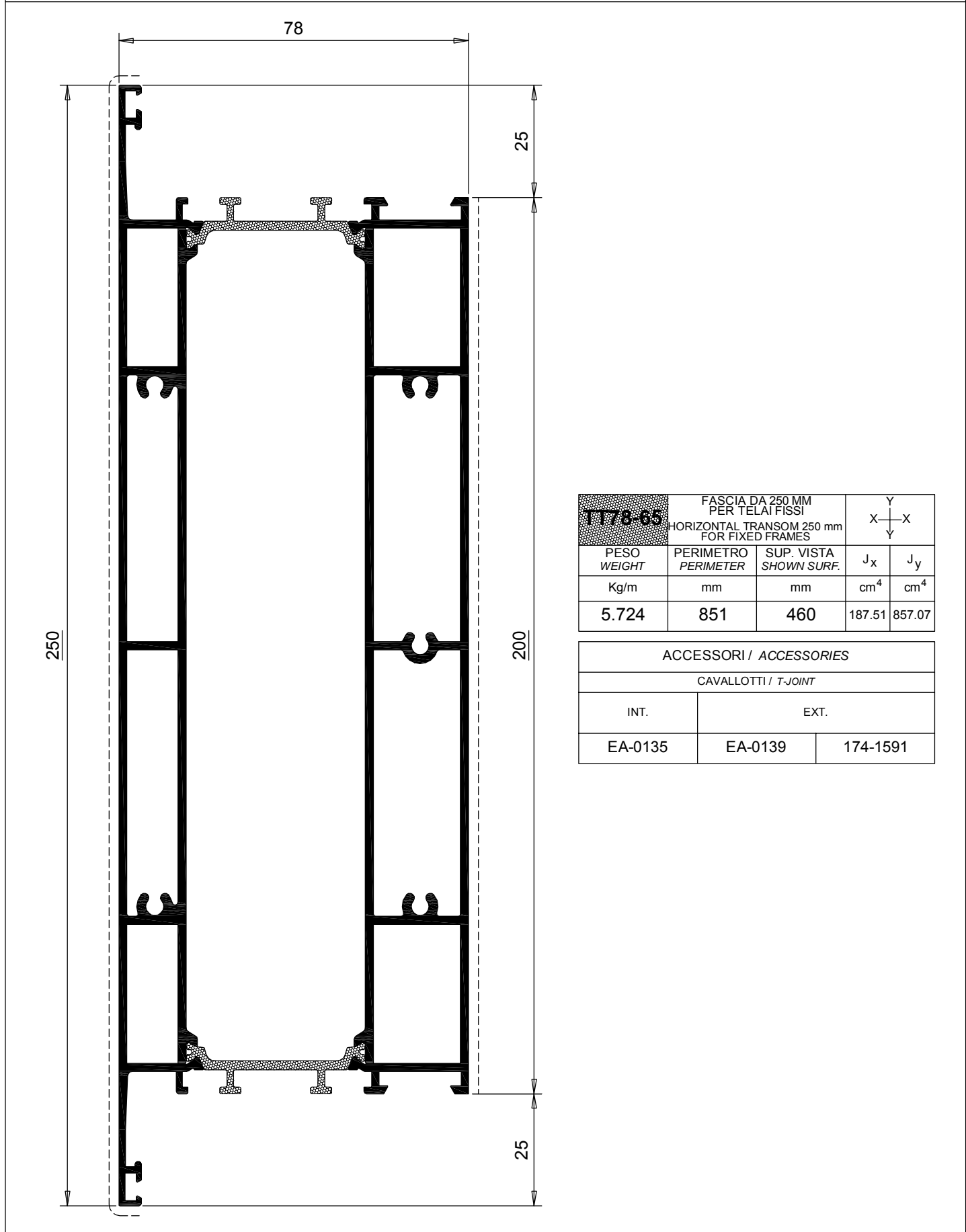

T178-65	FASCIA DA 250 MM PER TELAI FISSI			
	HORIZONTAL TRANSOM 250 mm FOR FIXED FRAMES			
PESO WEIGHT	PERIMETRO PERIMETER	SUP. VISTA SHOWN SURF.	J _x	J _y
Kg/m	mm	mm	cm ⁴	cm ⁴
5.724	851	460	187.51	857.07

ACCESSORI / ACCESSORIES		
CAVALLOTTI / T-JOINT		
INT.	EXT.	
EA-0135	EA-0139	174-1591

Note:  = profilo non a stock
profile no stock

Profili 1:1 - Profiles 1:1

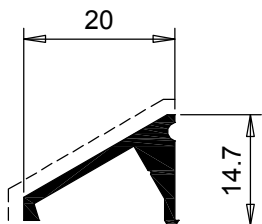

5767	GOCCIOLATOIO WATER DRAINAGE	
PESO WEIGHT	PERIMETRO PERIMETER	SUP. VISTA SHOWN SURF.
Kg/m	mm	mm
0.190	75	26

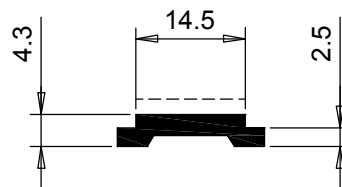

6405	ASTINA DI COMANDO CHIUSURE CLOSING ROD	
PESO WEIGHT	PERIMETRO PERIMETER	SUP. VISTA SHOWN SURF.
Kg/m	mm	mm
0.159	49	15

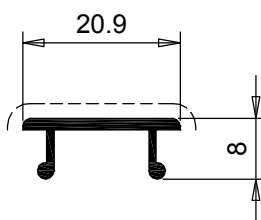

20575	COPRIFILO COVER JOINT	
PESO WEIGHT	PERIMETRO PERIMETER	SUP. VISTA SHOWN SURF.
Kg/m	mm	mm
0.235	137	46

Note:  = profilo non a stock
profile no stock

Profili 1:1 - Profiles 1:1

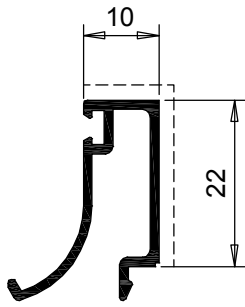

16185	FERMAVETRO DA 10 mm GLASS BEADING 10 mm	
PESO WEIGHT	PERIMETRO PERIMETER	SUP. VISTA SHOWN SURF.
Kg/m	mm	mm
0.237	150	31

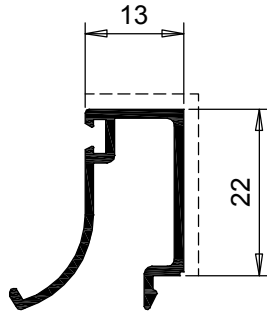

16186	FERMAVETRO DA 13 mm GLASS BEADING 13 mm	
PESO WEIGHT	PERIMETRO PERIMETER	SUP. VISTA SHOWN SURF.
Kg/m	mm	mm
0.243	152	35

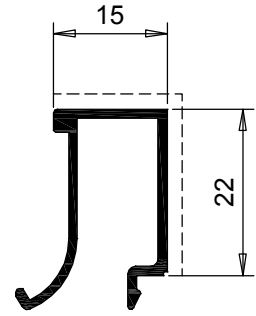

19712	FERMAVETRO DA 15 mm GLASS BEADING 15 mm	
PESO WEIGHT	PERIMETRO PERIMETER	SUP. VISTA SHOWN SURF.
Kg/m	mm	mm
0.242	149	36

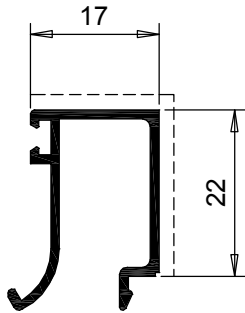

16189	FERMAVETRO DA 17 mm GLASS BEADING 17 mm	
PESO WEIGHT	PERIMETRO PERIMETER	SUP. VISTA SHOWN SURF.
Kg/m	mm	mm
0.252	159	39

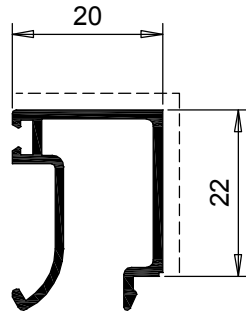

22618	FERMAVETRO DA 20 mm GLASS BEADING 20 mm	
PESO WEIGHT	PERIMETRO PERIMETER	SUP. VISTA SHOWN SURF.
Kg/m	mm	mm
0.271	170	42

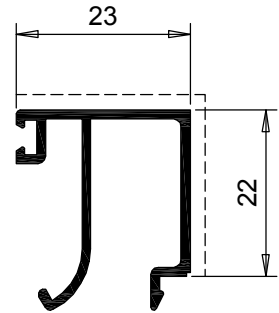

16191	FERMAVETRO DA 23 mm GLASS BEADING 23 mm	
PESO WEIGHT	PERIMETRO PERIMETER	SUP. VISTA SHOWN SURF.
Kg/m	mm	mm
0.290	183	44

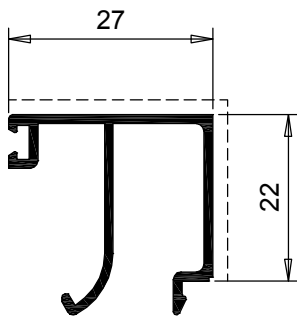

16193	FERMAVETRO DA 27 mm GLASS BEADING 27 mm	
PESO WEIGHT	PERIMETRO PERIMETER	SUP. VISTA SHOWN SURF.
Kg/m	mm	mm
0.303	190	48

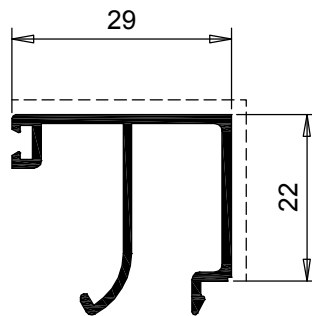

16195	FERMAVETRO DA 29 mm GLASS BEADING 29 mm	
PESO WEIGHT	PERIMETRO PERIMETER	SUP. VISTA SHOWN SURF.
Kg/m	mm	mm
0.310	195	50

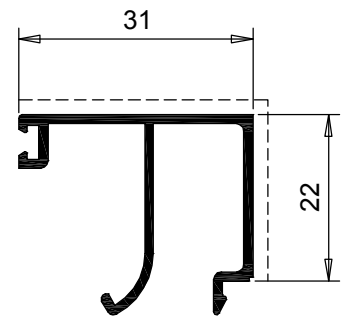

16197	FERMAVETRO DA 31 mm GLASS BEADING 31 mm	
PESO WEIGHT	PERIMETRO PERIMETER	SUP. VISTA SHOWN SURF.
Kg/m	mm	mm
0.316	199	52

Profili 1:1 - Profiles 1:1

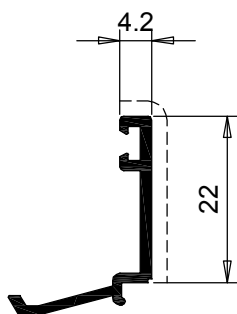

4293	FERMAVETRO DA 4 mm GLASS BEADING 4 mm	
PESO WEIGHT	PERIMETRO PERIMETER	SUP. VISTA SHOWN SURF.
Kg/m	mm	mm
0.183	102	25

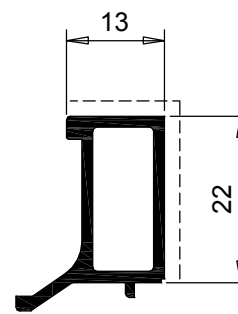

19873	FERMAVETRO DA 13 mm GLASS BEADING 13 mm	
PESO WEIGHT	PERIMETRO PERIMETER	SUP. VISTA SHOWN SURF.
Kg/m	mm	mm
0.314	92	34

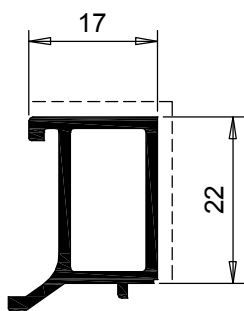

19874	FERMAVETRO DA 17 mm GLASS BEADING 17 mm	
PESO WEIGHT	PERIMETRO PERIMETER	SUP. VISTA SHOWN SURF.
Kg/m	mm	mm
0.328	100	38

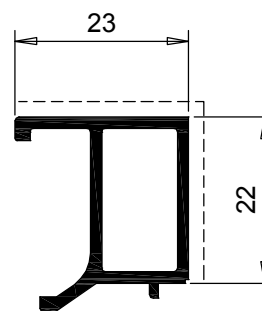

19875	FERMAVETRO DA 23 mm GLASS BEADING 23 mm	
PESO WEIGHT	PERIMETRO PERIMETER	SUP. VISTA SHOWN SURF.
Kg/m	mm	mm
0.352	112	44

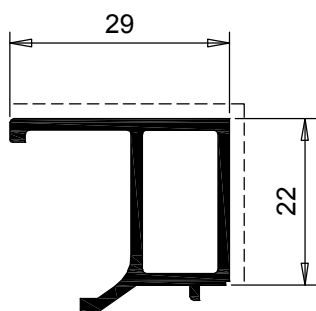

19876	FERMAVETRO DA 29 mm GLASS BEADING 29 mm	
PESO WEIGHT	PERIMETRO PERIMETER	SUP. VISTA SHOWN SURF.
Kg/m	mm	mm
0.376	124	50

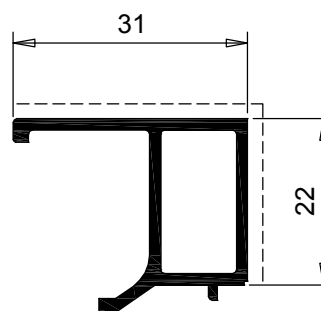

19877	FERMAVETRO DA 31 mm GLASS BEADING 31 mm	
PESO WEIGHT	PERIMETRO PERIMETER	SUP. VISTA SHOWN SURF.
Kg/m	mm	mm
0.385	128	52

Note:  = profilo non a stock
profile no stock

Profili 1:1 - Profiles 1:1

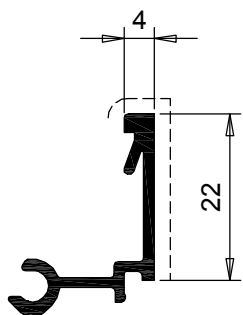

24565	FERMAVETRO DA 4 mm GLASS BEADING 4 mm	
PESO WEIGHT	PERIMETRO PERIMETER	SUP. VISTA SHOWN SURF.
Kg/m	mm	mm
0.233	115	26

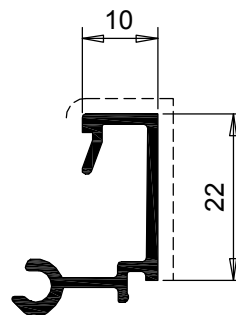

24566	FERMAVETRO DA 10 mm GLASS BEADING 10 mm	
PESO WEIGHT	PERIMETRO PERIMETER	SUP. VISTA SHOWN SURF.
Kg/m	mm	mm
0.255	133	32

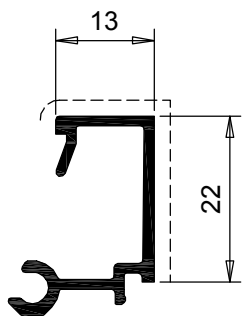

24567	FERMAVETRO DA 13 mm GLASS BEADING 13 mm	
PESO WEIGHT	PERIMETRO PERIMETER	SUP. VISTA SHOWN SURF.
Kg/m	mm	mm
0.265	139	35

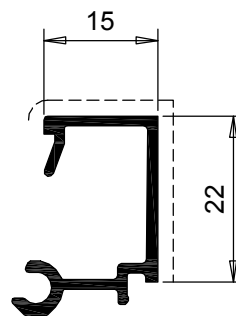

24568	FERMAVETRO DA 15 mm GLASS BEADING 15 mm	
PESO WEIGHT	PERIMETRO PERIMETER	SUP. VISTA SHOWN SURF.
Kg/m	mm	mm
0.272	143	37

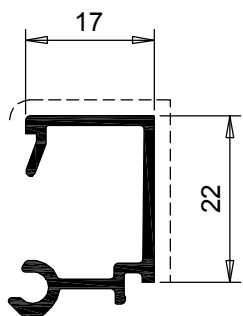

24569	FERMAVETRO DA 17 mm GLASS BEADING 17 mm	
PESO WEIGHT	PERIMETRO PERIMETER	SUP. VISTA SHOWN SURF.
Kg/m	mm	mm
0.279	147	39

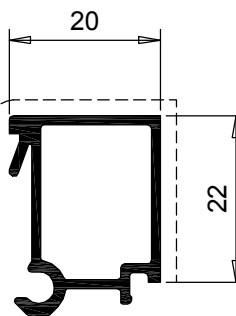

24570	FERMAVETRO DA 20 mm GLASS BEADING 20 mm	
PESO WEIGHT	PERIMETRO PERIMETER	SUP. VISTA SHOWN SURF.
Kg/m	mm	mm
0.332	114	42

Note:  = profilo non a stock
profile no stock

Profili 1:1 - Profiles 1:1

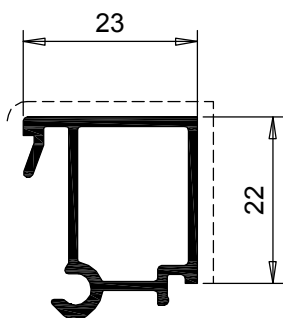

24571	FERMAVETRO DA 23 mm GLASS BEADING 23 mm	
PESO WEIGHT	PERIMETRO PERIMETER	SUP. VISTA SHOWN SURF.
Kg/m	mm	mm
0.340	125	45

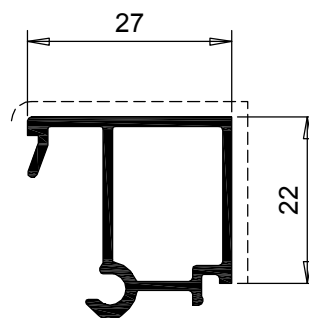

24572	FERMAVETRO DA 27 mm GLASS BEADING 27 mm	
PESO WEIGHT	PERIMETRO PERIMETER	SUP. VISTA SHOWN SURF.
Kg/m	mm	mm
0.352	133	49

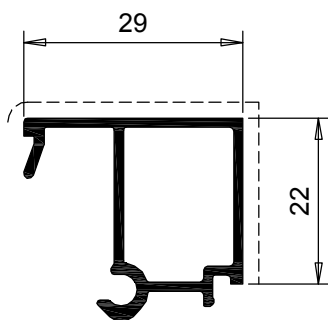

24573	FERMAVETRO DA 29 mm GLASS BEADING 29 mm	
PESO WEIGHT	PERIMETRO PERIMETER	SUP. VISTA SHOWN SURF.
Kg/m	mm	mm
0.359	137	51

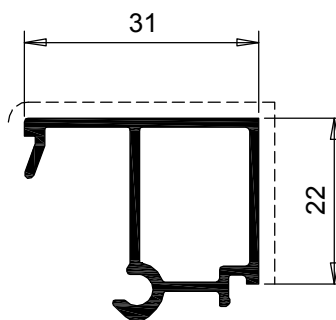

24528	FERMAVETRO DA 31 mm GLASS BEADING 31 mm	
PESO WEIGHT	PERIMETRO PERIMETER	SUP. VISTA SHOWN SURF.
Kg/m	mm	mm
0.366	141	53

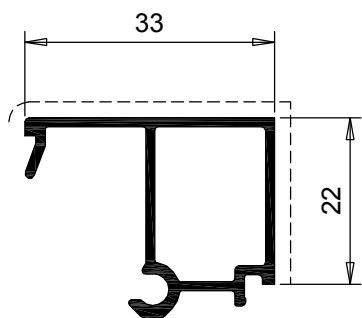

24556	FERMAVETRO DA 33 mm GLASS BEADING 33 mm	
PESO WEIGHT	PERIMETRO PERIMETER	SUP. VISTA SHOWN SURF.
Kg/m	mm	mm
0.372	145	55

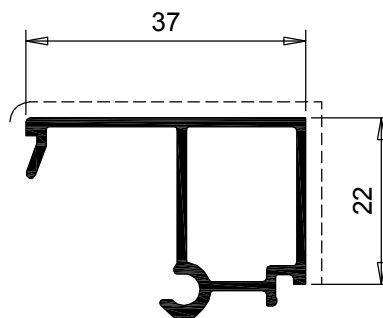

24557	FERMAVETRO DA 37 mm GLASS BEADING 37 mm	
PESO WEIGHT	PERIMETRO PERIMETER	SUP. VISTA SHOWN SURF.
Kg/m	mm	mm
0.385	153	59

Note:  = profilo non a stock
profile no stock

Profili 1:1 - Profiles 1:1

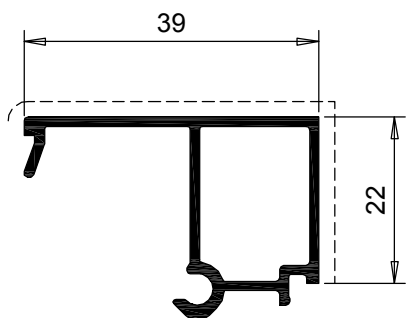

24558	FERMAVETRO DA 39 mm GLASS BEADING 39 mm	
PESO WEIGHT	PERIMETRO PERIMETER	SUP. VISTA SHOWN SURF.
Kg/m	mm	mm
0.392	157	61

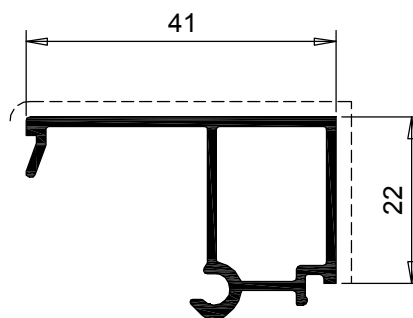

24559	FERMAVETRO DA 41 mm GLASS BEADING 41 mm	
PESO WEIGHT	PERIMETRO PERIMETER	SUP. VISTA SHOWN SURF.
Kg/m	mm	mm
0.399	159	63

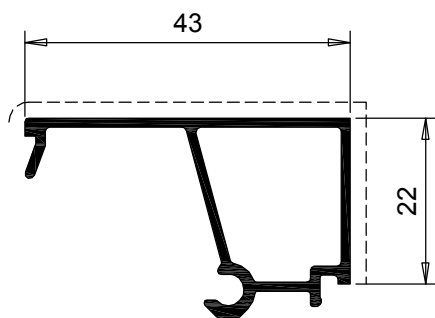

24560	FERMAVETRO DA 43 mm GLASS BEADING 43 mm	
PESO WEIGHT	PERIMETRO PERIMETER	SUP. VISTA SHOWN SURF.
Kg/m	mm	mm
0.407	161	65

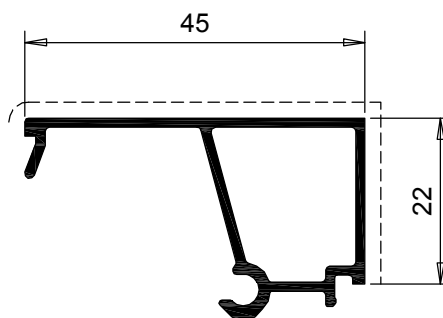

24561	FERMAVETRO DA 45 mm GLASS BEADING 45 mm	
PESO WEIGHT	PERIMETRO PERIMETER	SUP. VISTA SHOWN SURF.
Kg/m	mm	mm
0.414	163	67

Note:  = profilo non a stock
profile no stock

Profili 1:1 - Profiles 1:1

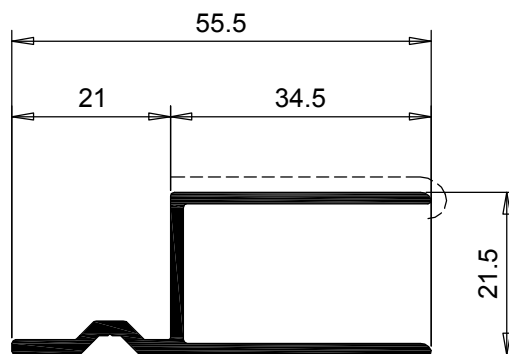
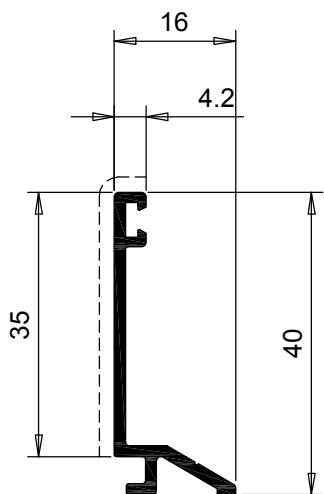

24533 BATTUTA RIPORTATA DA 35 mm ADDITIONAL RABBET 35 mm		
PESO WEIGHT	PERIMETRO PERIMETER	SUP. VISTA SHOWN SURF.
Kg/m	mm	mm
0.265	134	40

24534 IMBOTTE FOR EXPANSION PROFILE		
PESO WEIGHT	PERIMETRO PERIMETER	SUP. VISTA SHOWN SURF.
Kg/m	mm	mm
0.483	222	35

Note:  = profilo non a stock
profile no stock

Profili 1:1 - Profiles 1:1

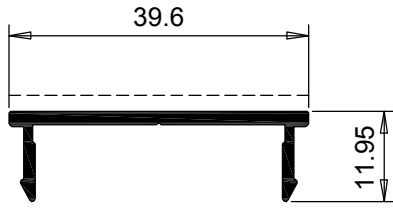

24523			COPERTINA RINFORZO REINFORCEMENT COVER		Y X-X Y	
PESO WEIGHT	PERIMETRO PERIMETER	SUP. VISTA SHOWN SURF.	J _x	J _y		
Kg/m	mm	mm	cm ⁴	cm ⁴		
0.270	123	39	-	1.78		

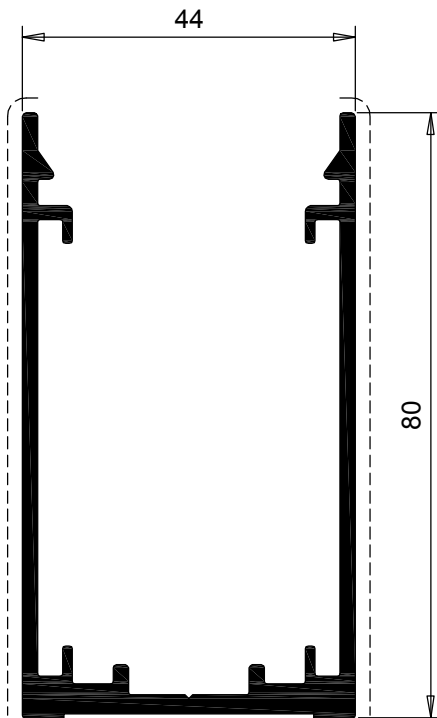

24524			RINFORZO REINFORCEMENT		Y X-X Y	
PESO WEIGHT	PERIMETRO PERIMETER	SUP. VISTA SHOWN SURF.	J _x	J _y		
Kg/m	mm	mm	cm ⁴	cm ⁴		
1.423	460	162	37.64	18.04		

Note:  = profilo non a stock
profile no stock

Profili 1:1 - Profiles 1:1

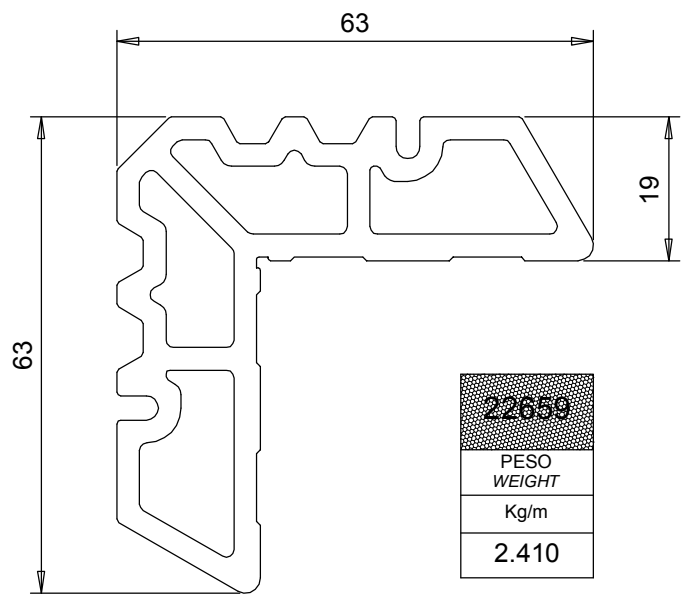
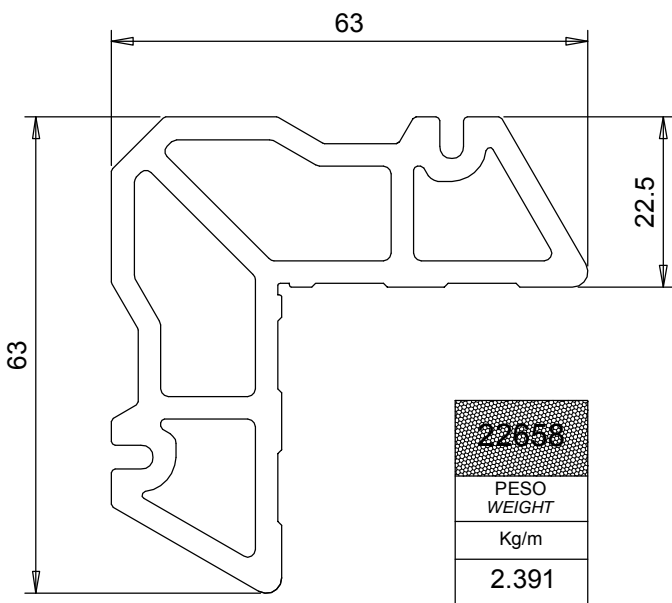
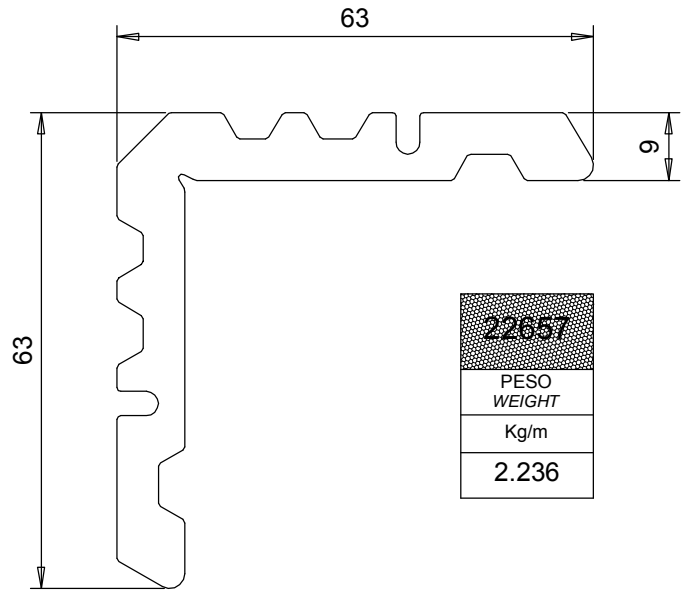
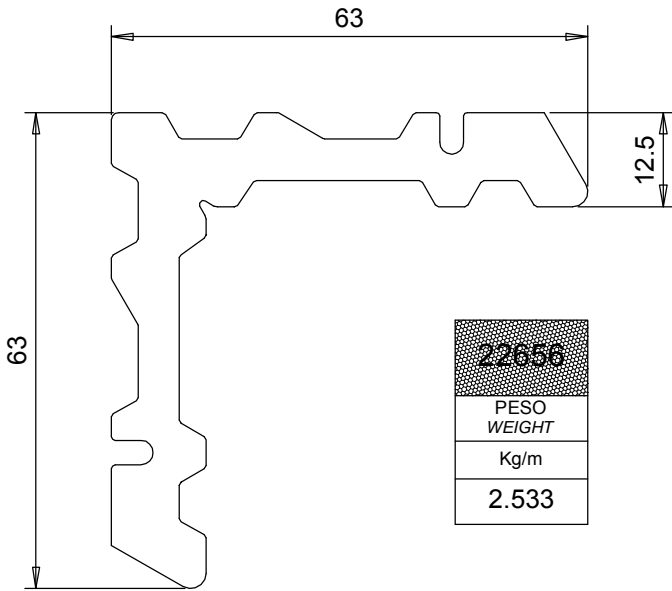

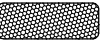
Note:  = profilo non a stock
profile no stock

Profili 1:1 - Profiles 1:1

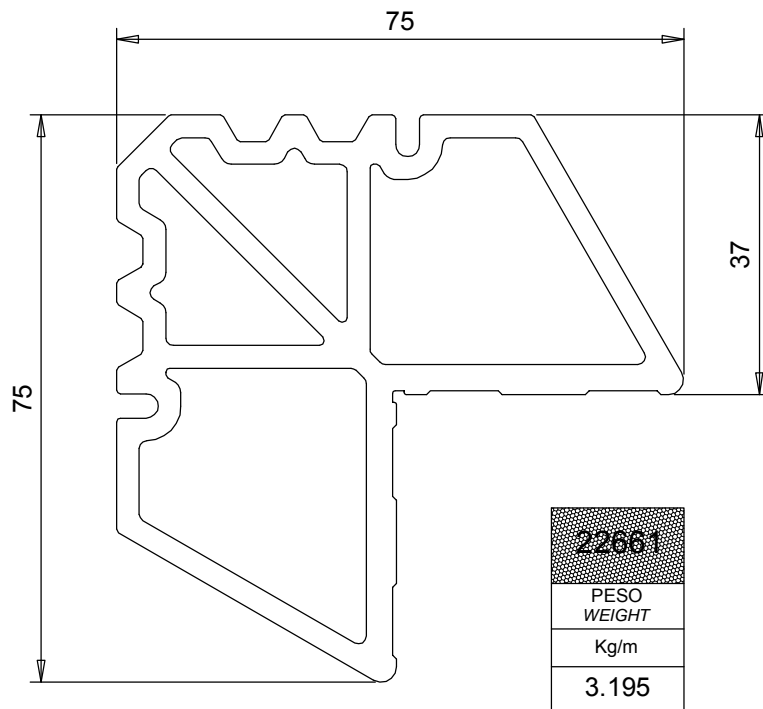
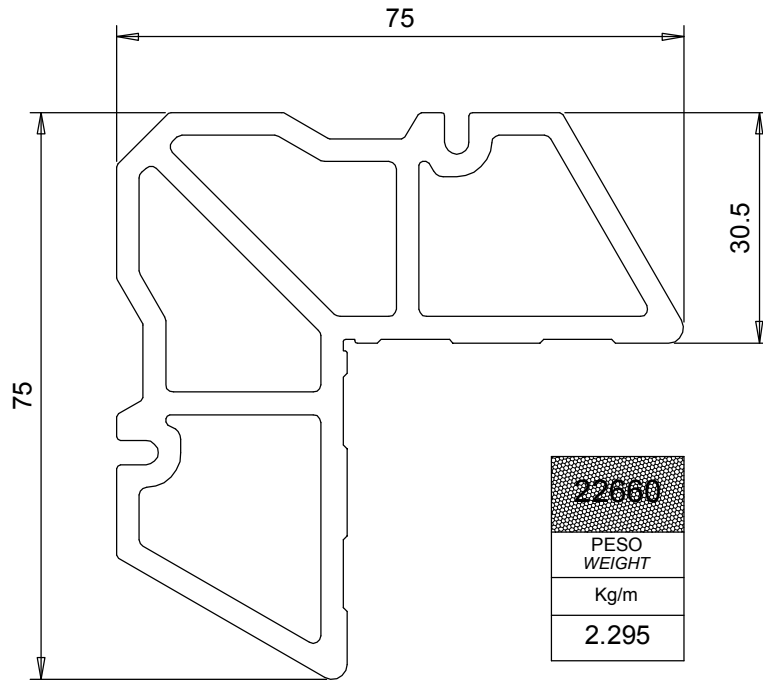

Note:  = profilo non a stock
profile no stock

Sezioni 1:1 - Cross sections 1:1

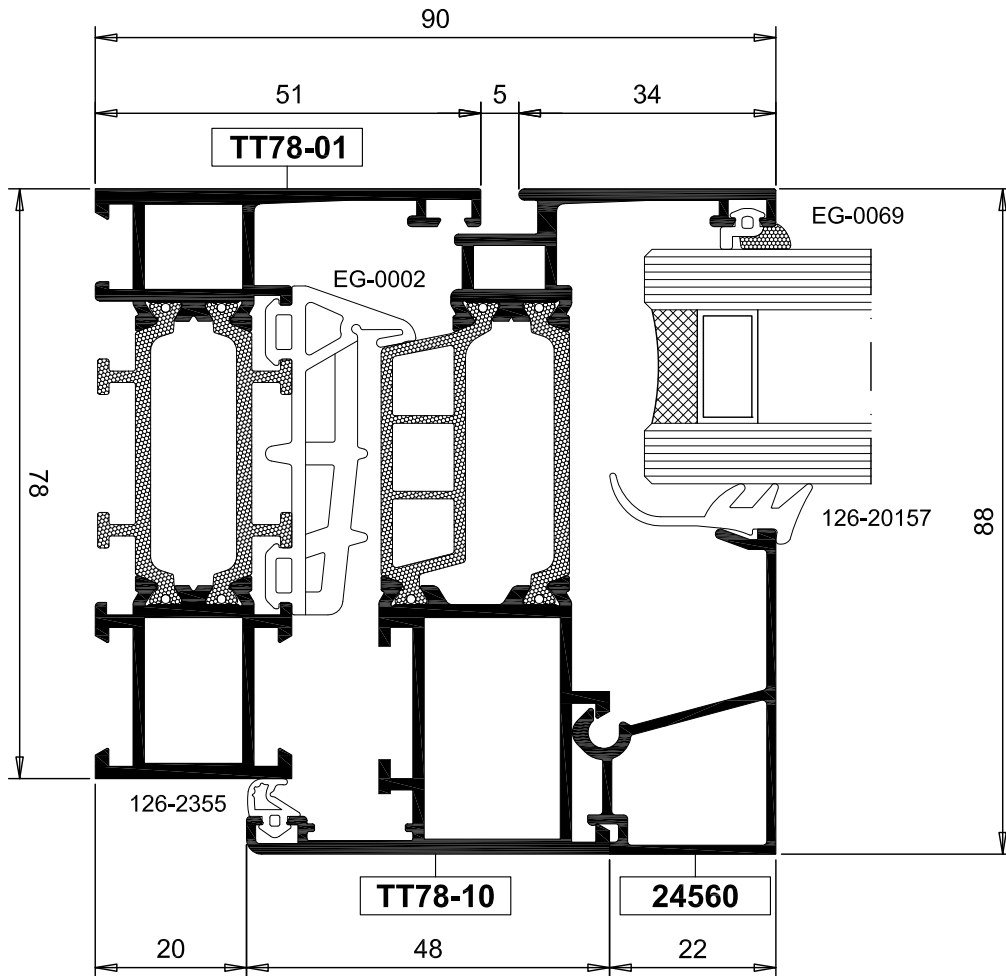
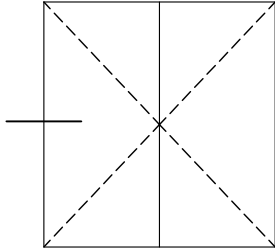

Sezioni 1:1 - Cross sections 1:1

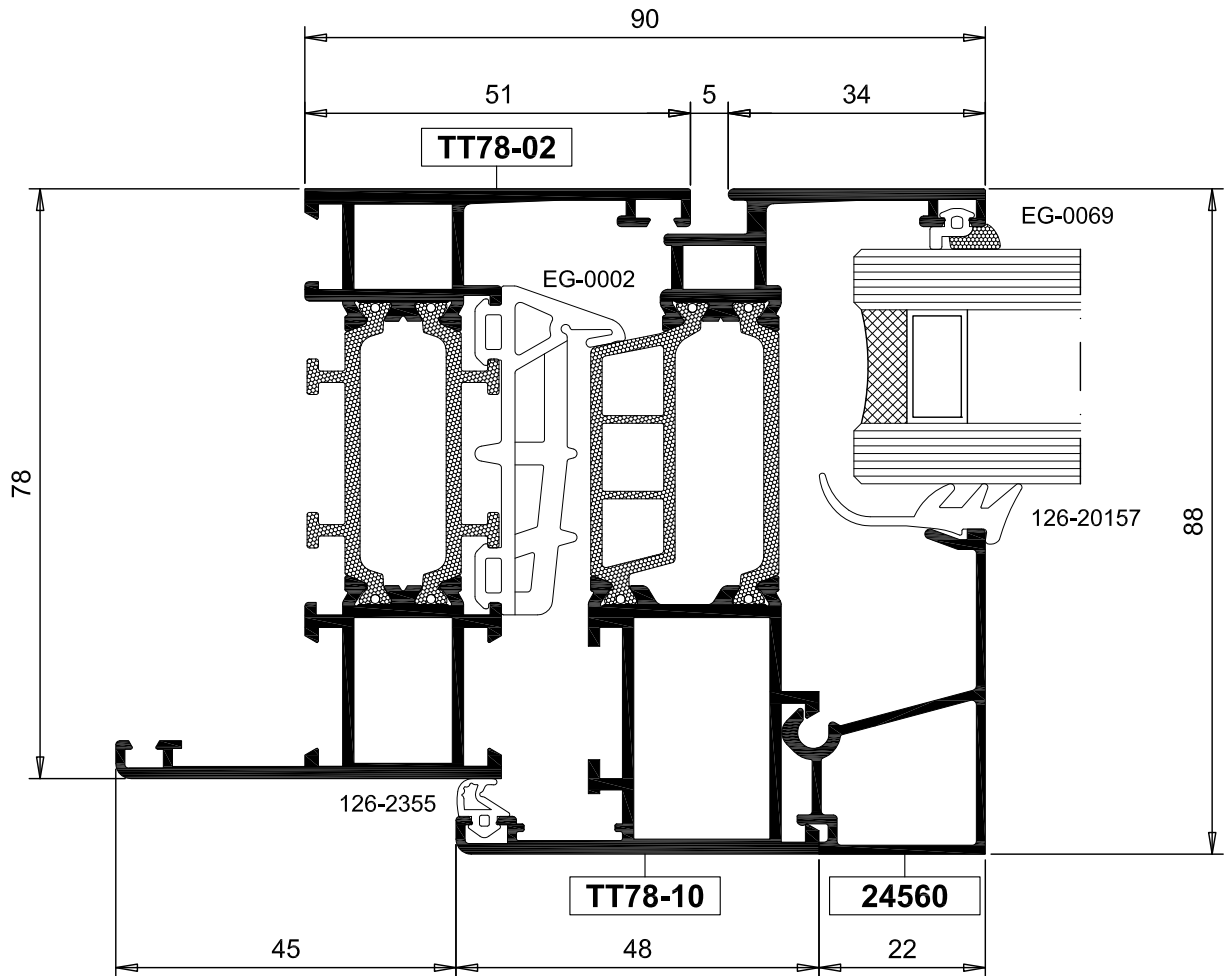
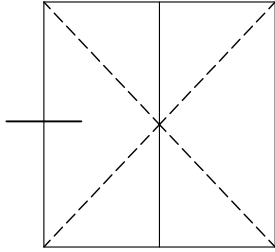

Sezioni 1:1 - Cross sections 1:1

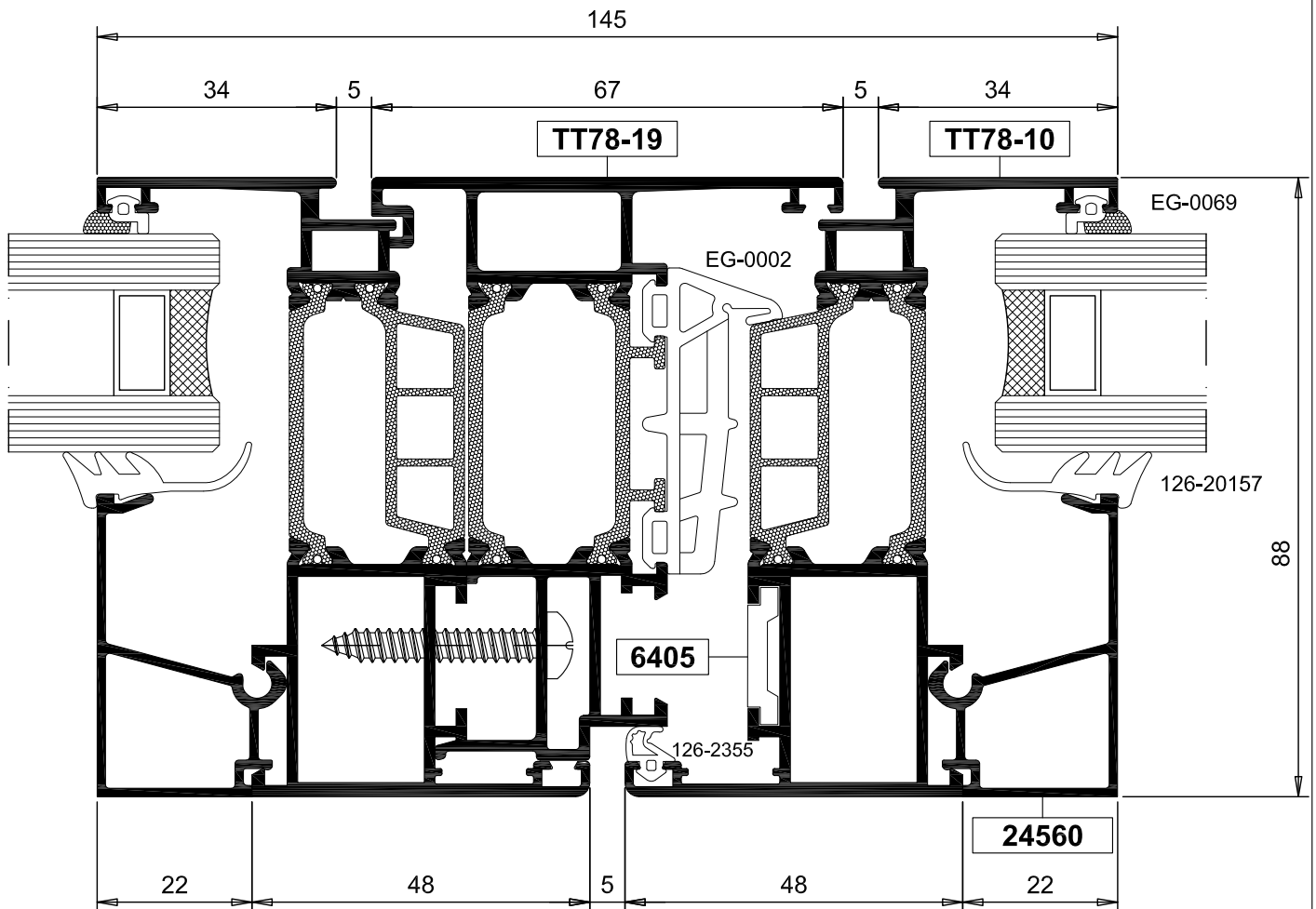
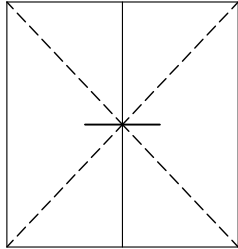

Sezioni 1:1 - Cross sections 1:1

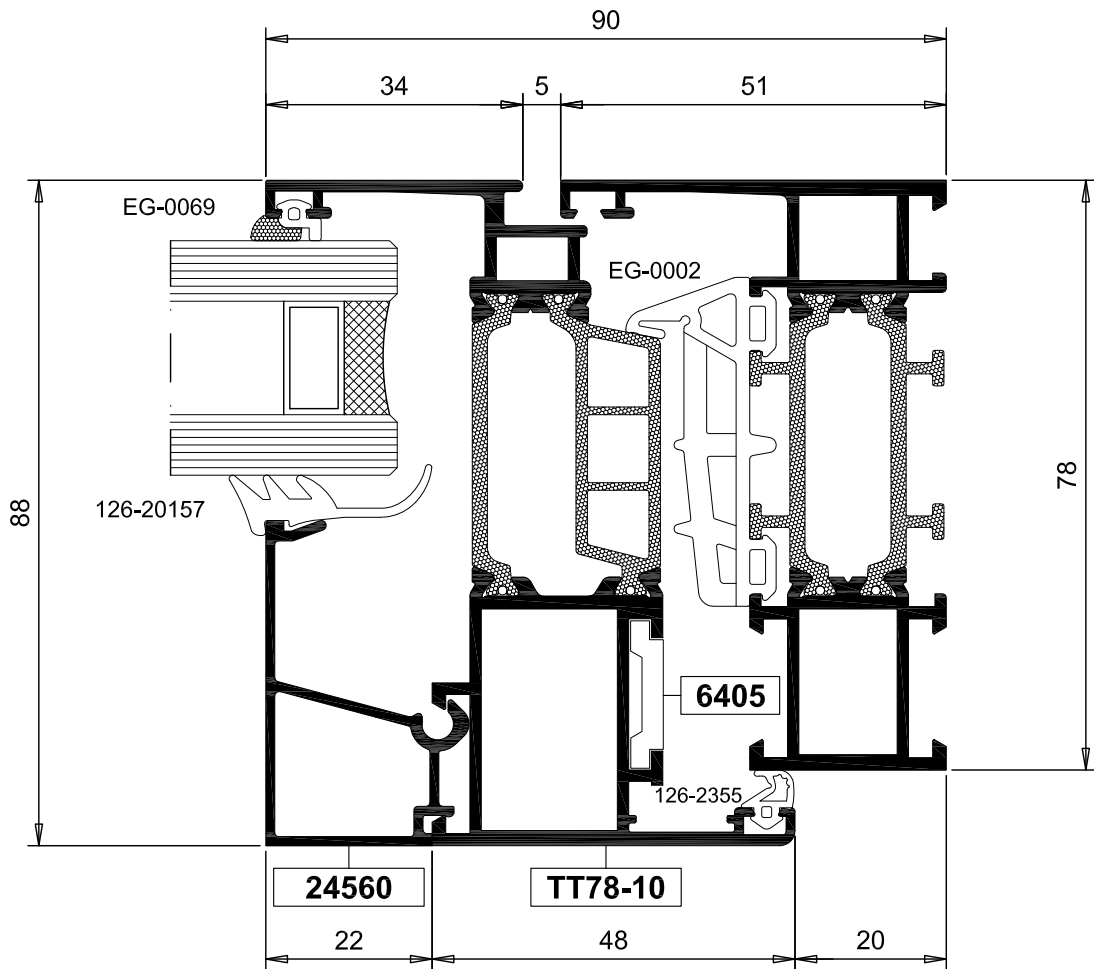
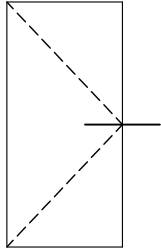

Sezioni 1:1 - Cross sections 1:1

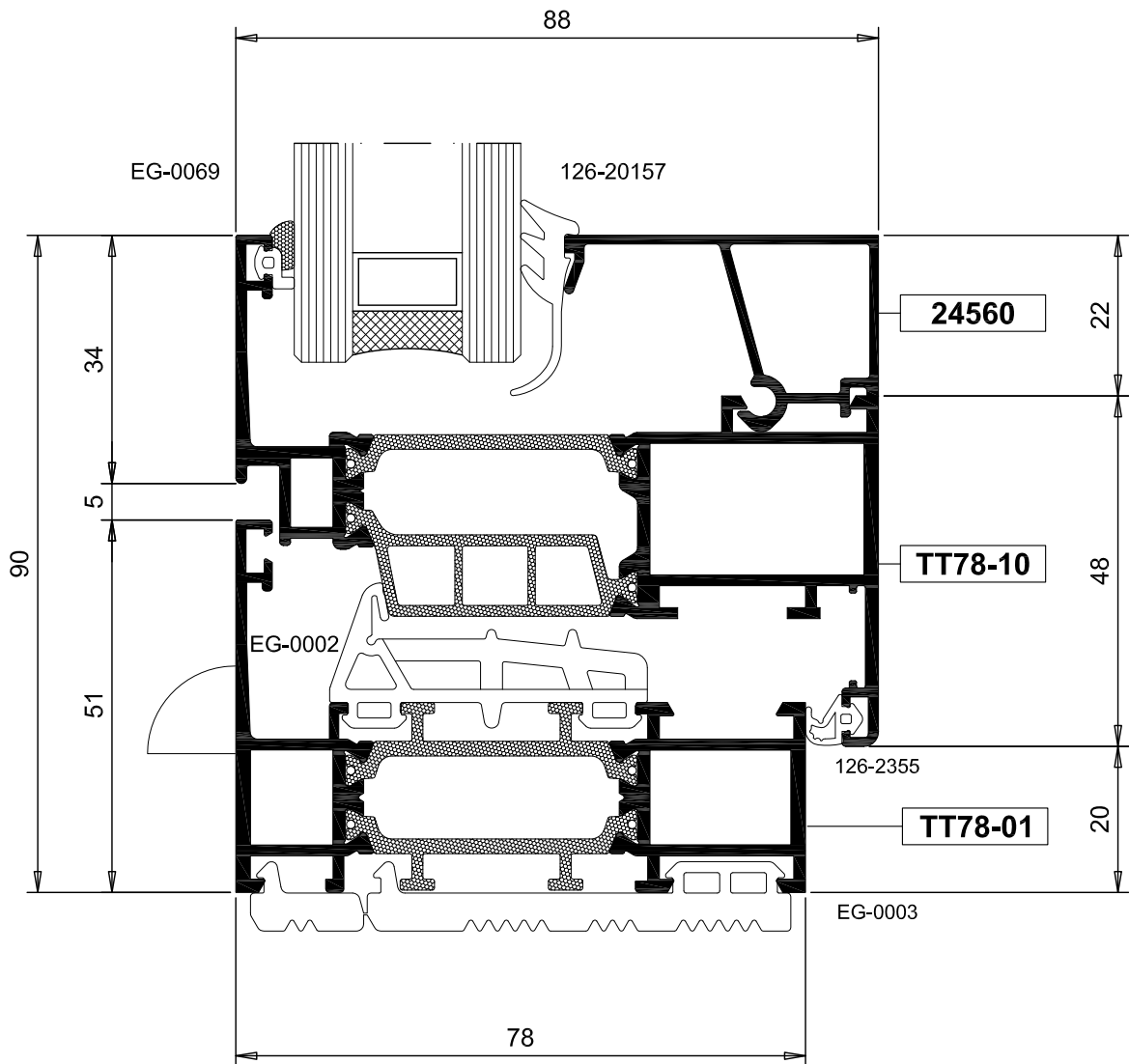
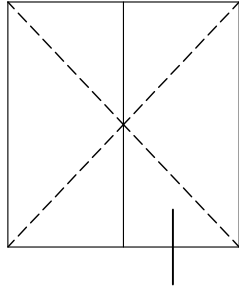

Sezioni 1:1 - Cross sections 1:1

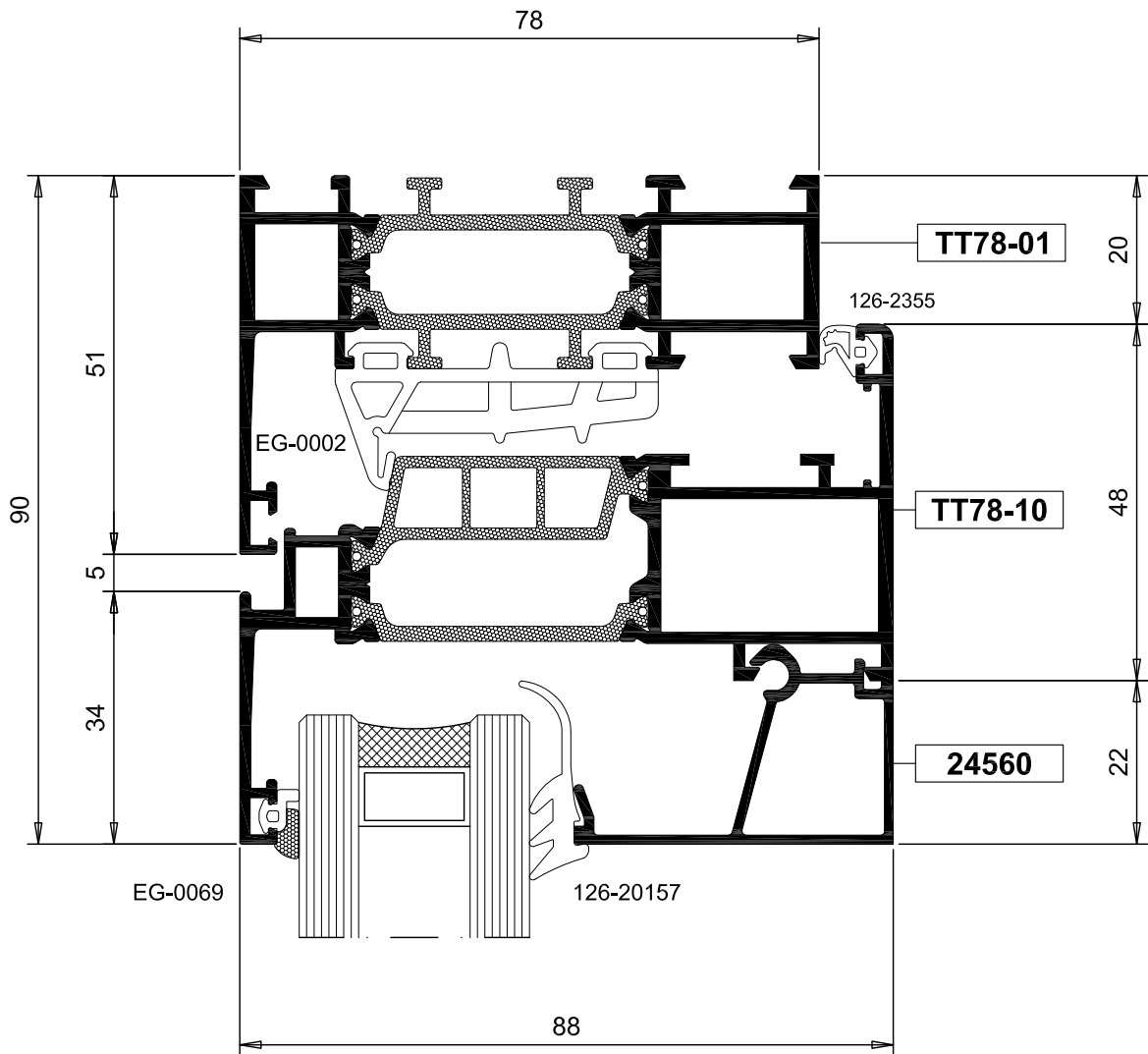
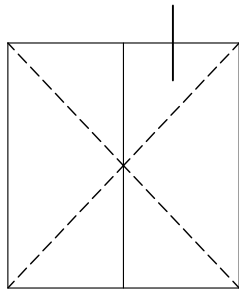

Sezioni 1:1 - Cross sections 1:1

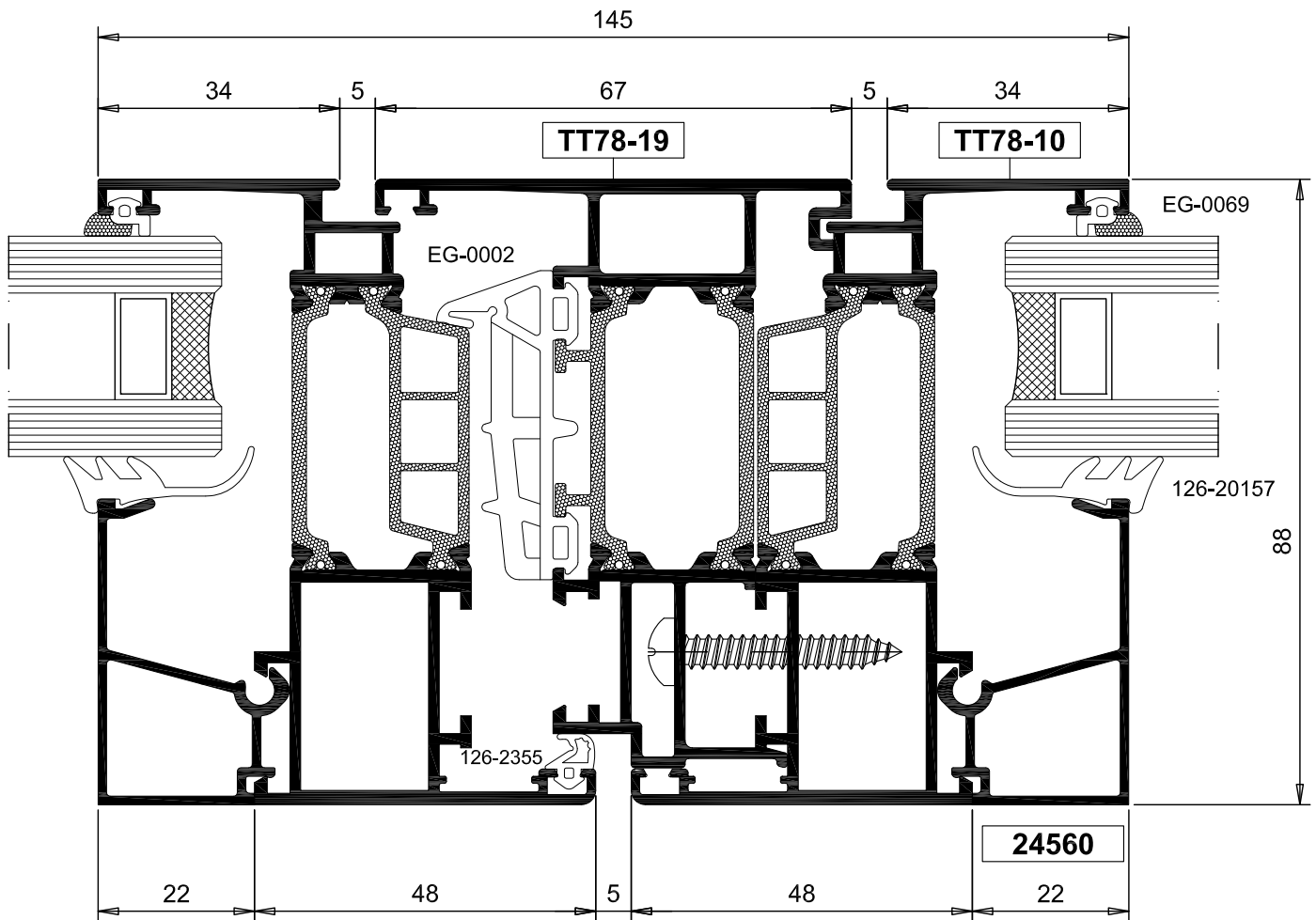
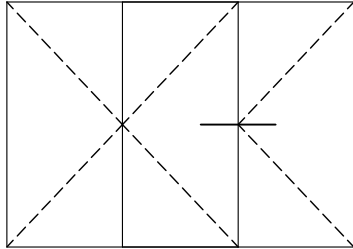

Sezioni 1:1 - Cross sections 1:1

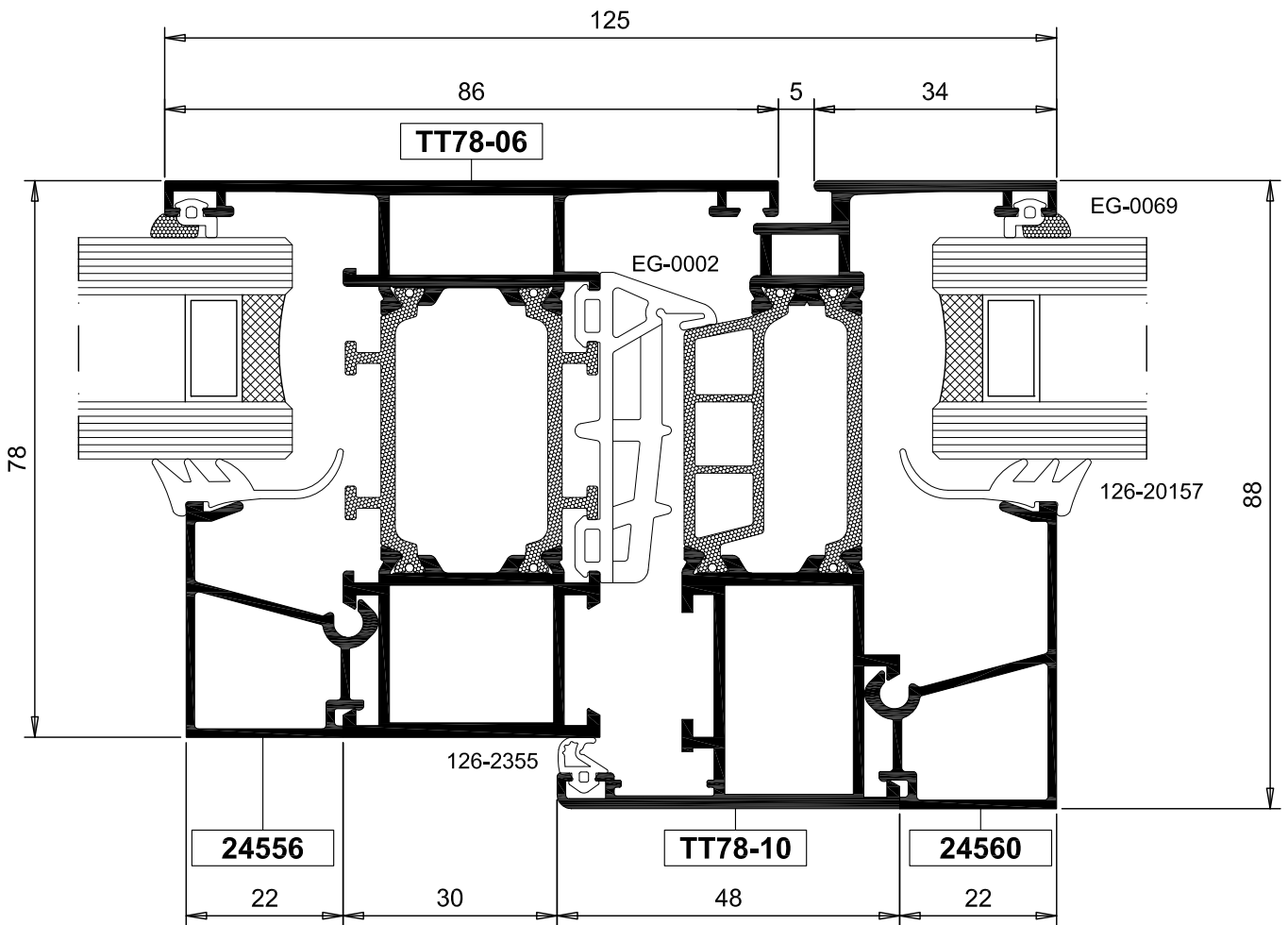
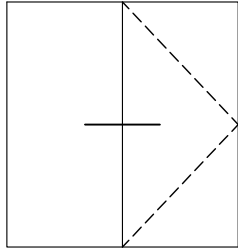

Sezioni 1:1 - Cross sections 1:1

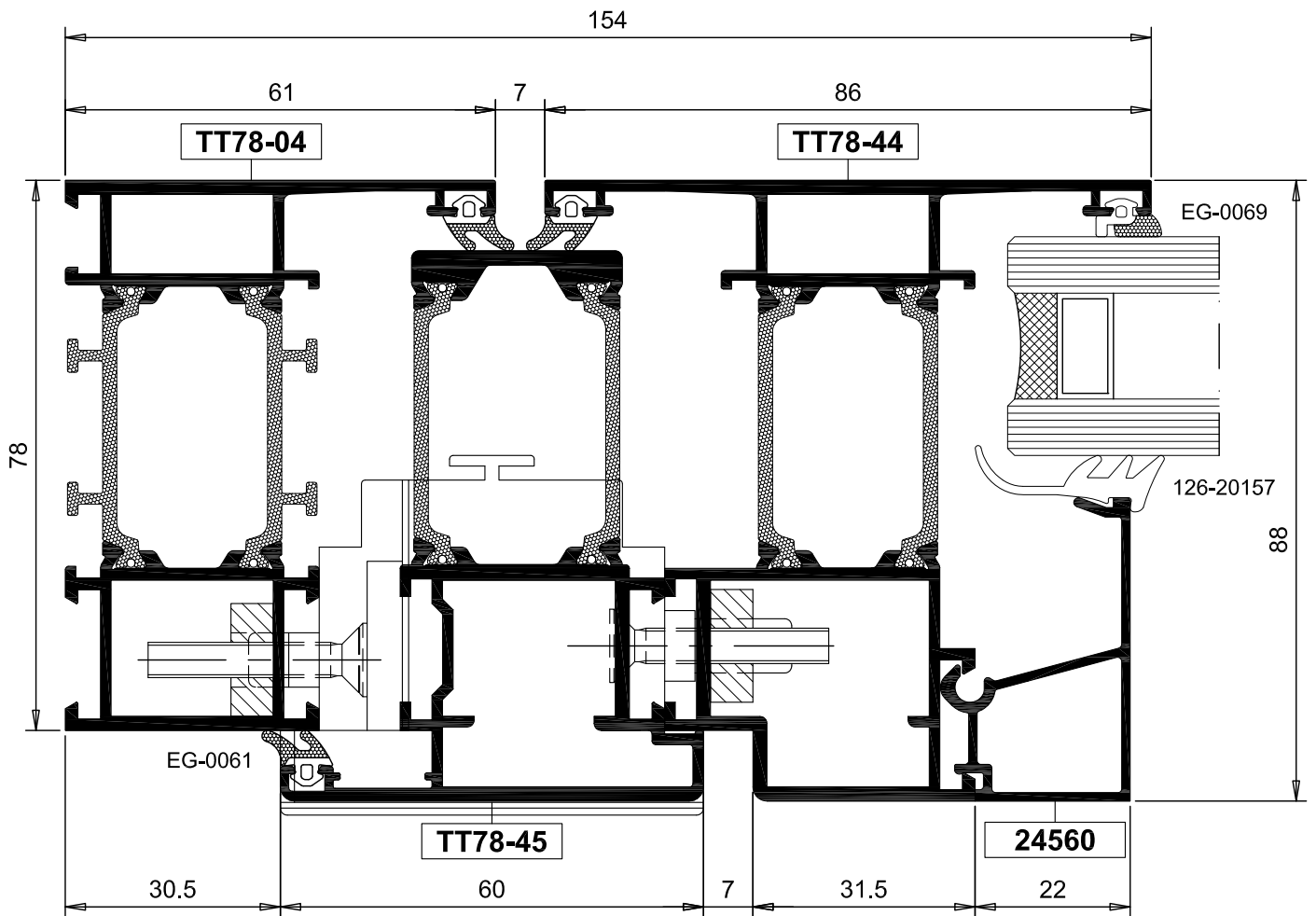
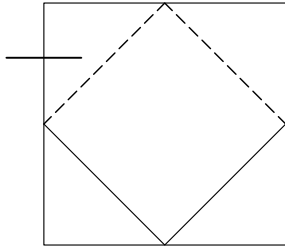

Sezioni 1:1 - Cross sections 1:1

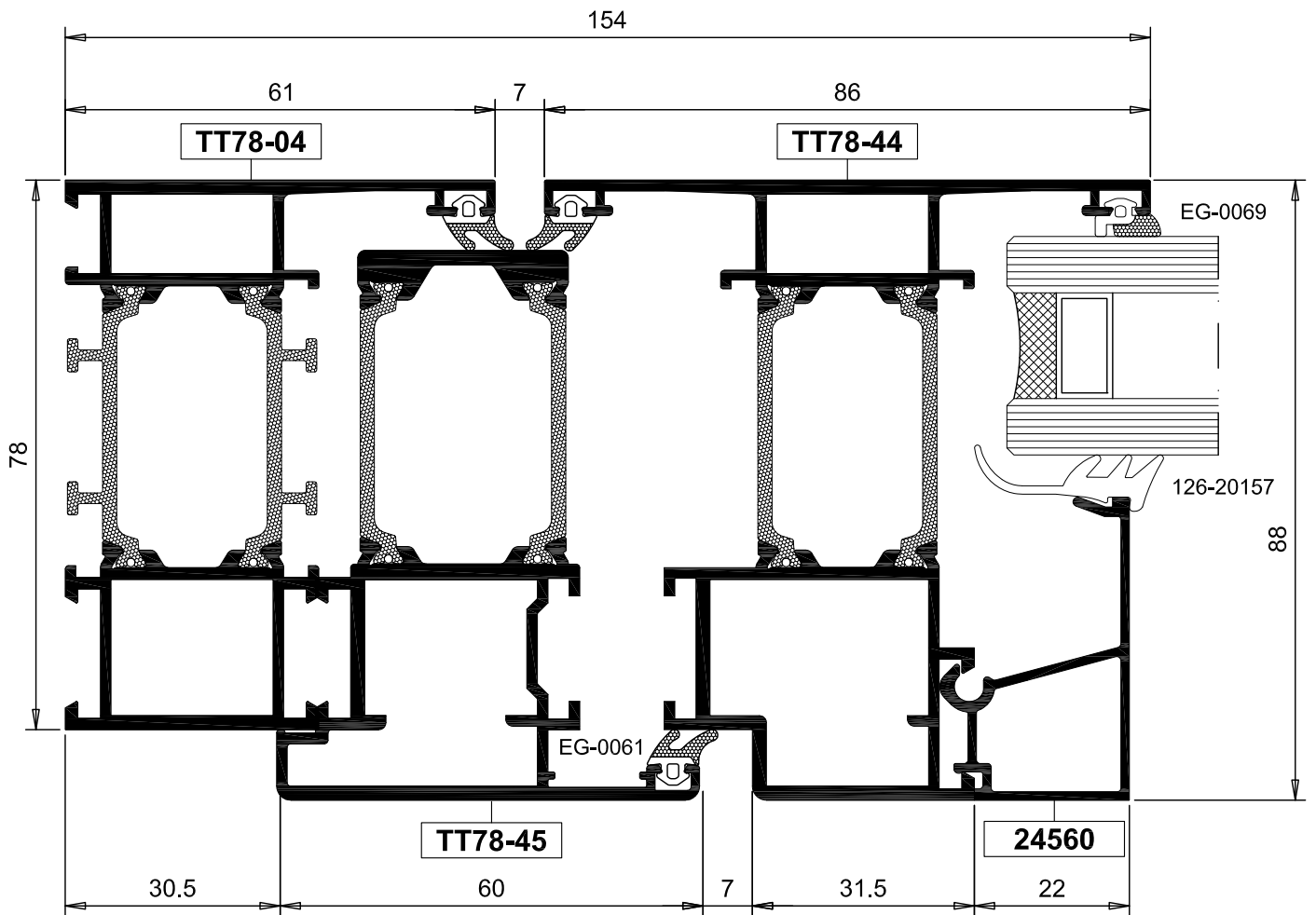
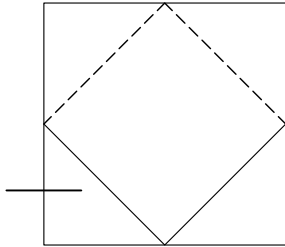

Sezioni 1:1 - Cross sections 1:1

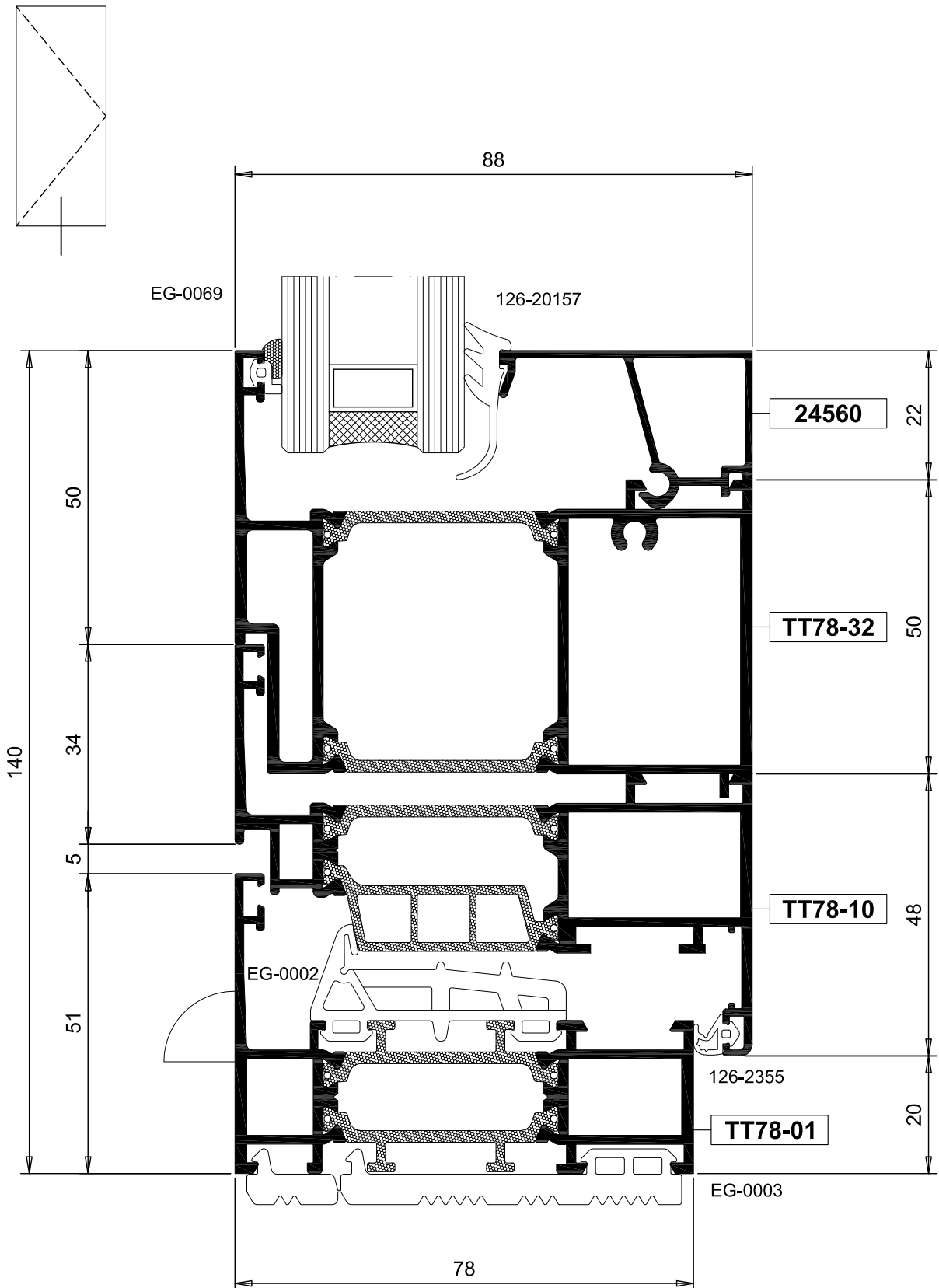

Sezioni 1:1 - Cross sections 1:1

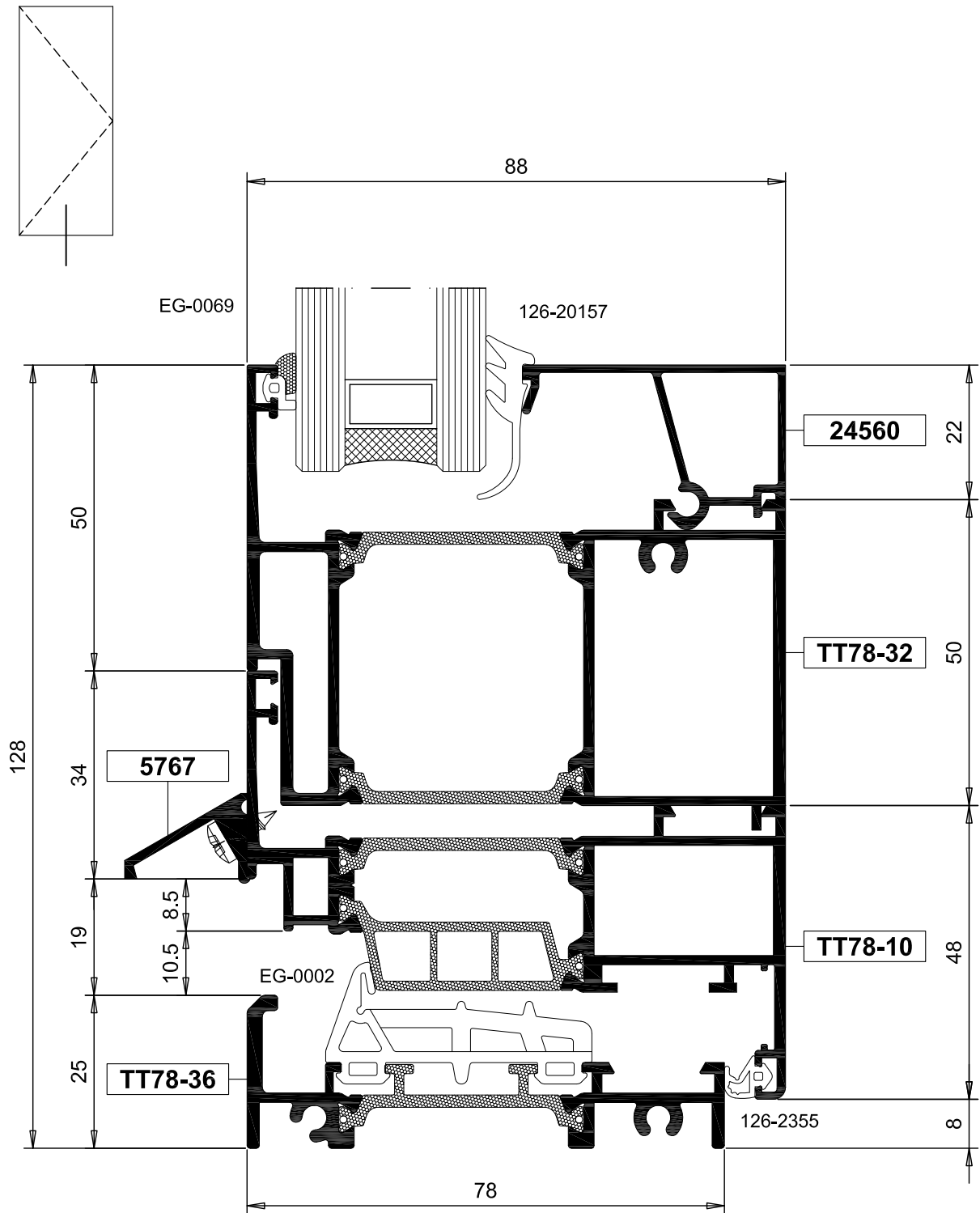

Sezioni 1:1 - Cross sections 1:1

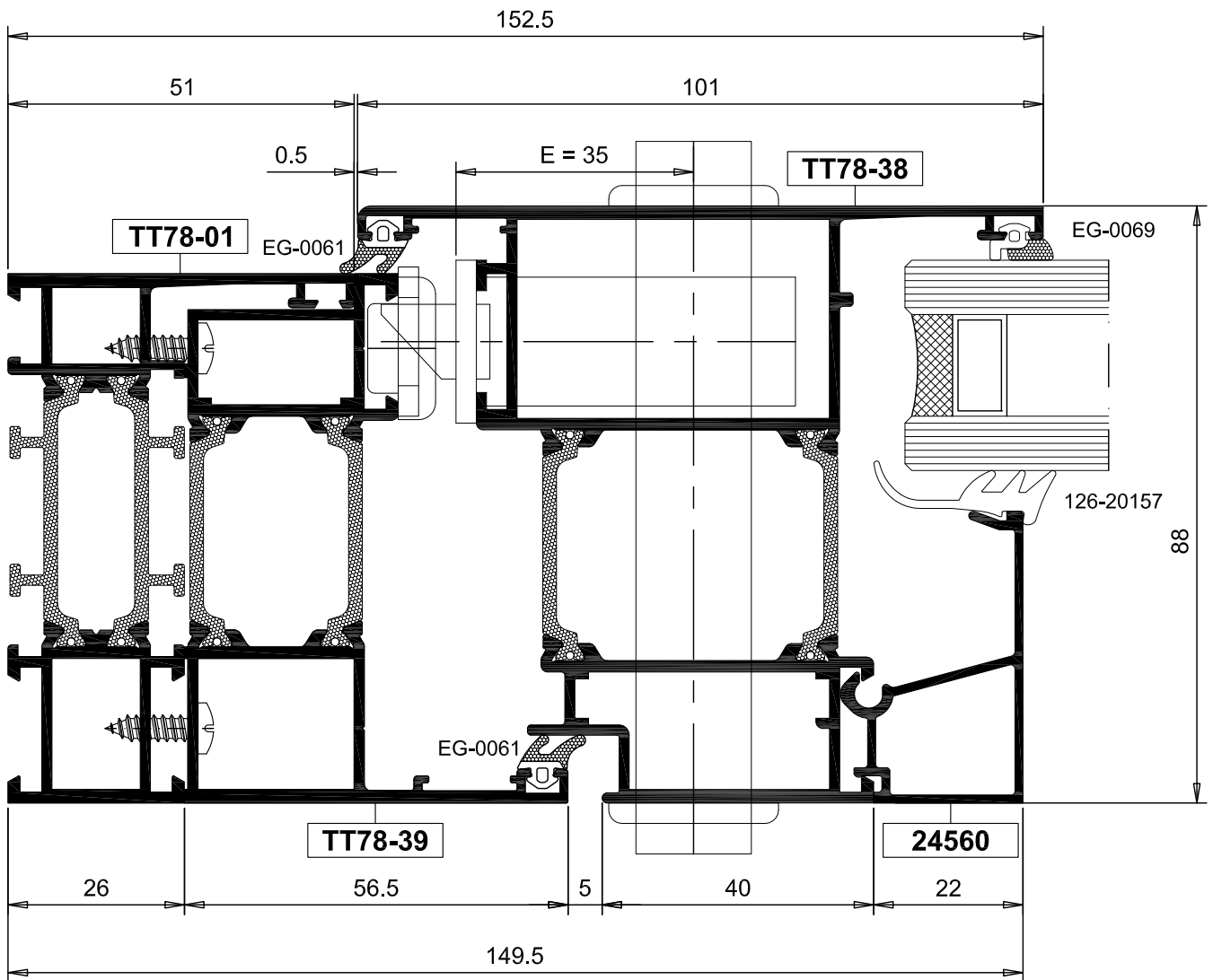
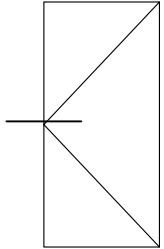

Sezioni 1:1 - Cross sections 1:1

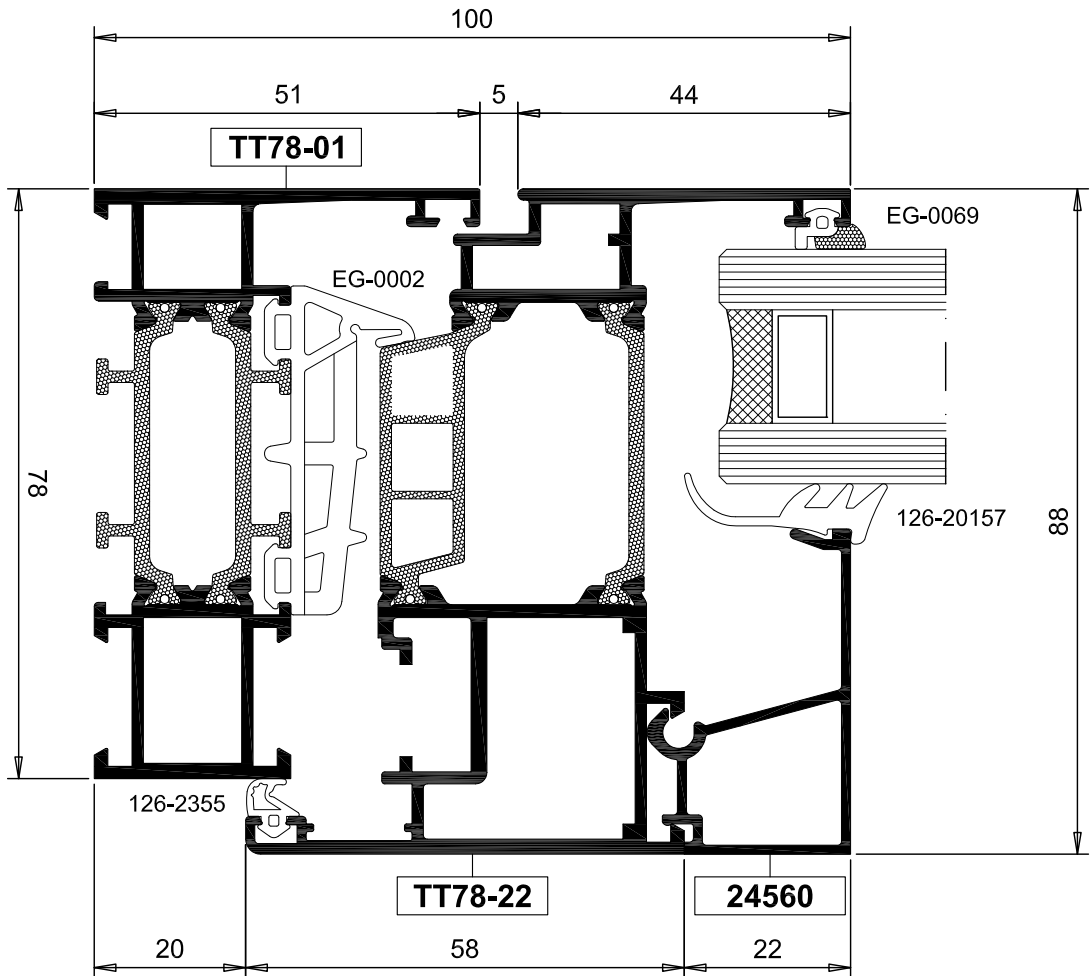
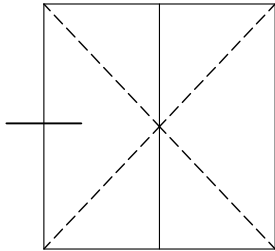

Sezioni 1:1 - Cross sections 1:1

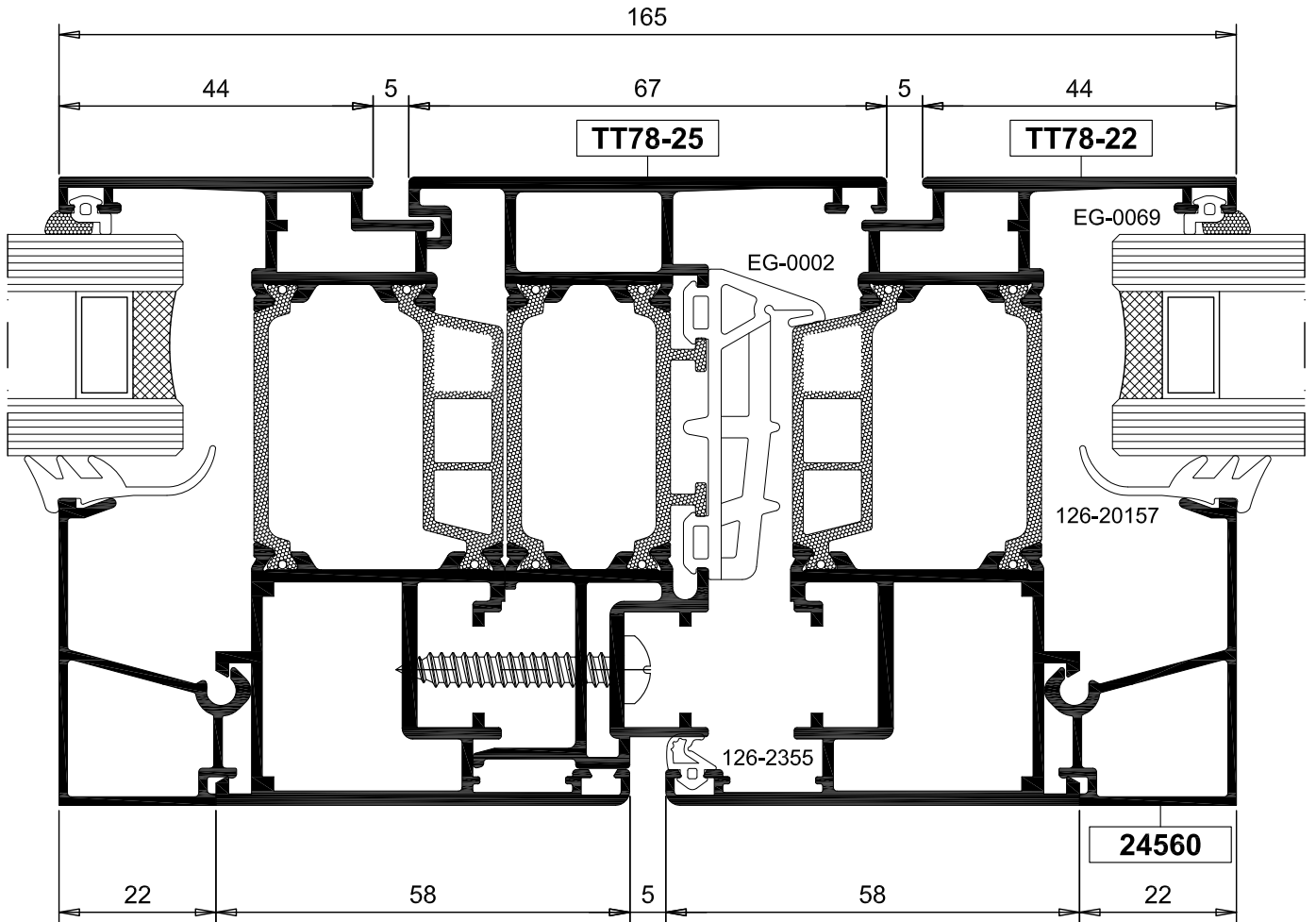
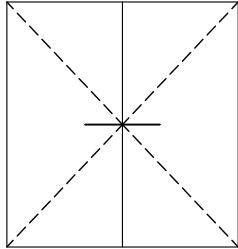

Sezioni 1:1 - Cross sections 1:1

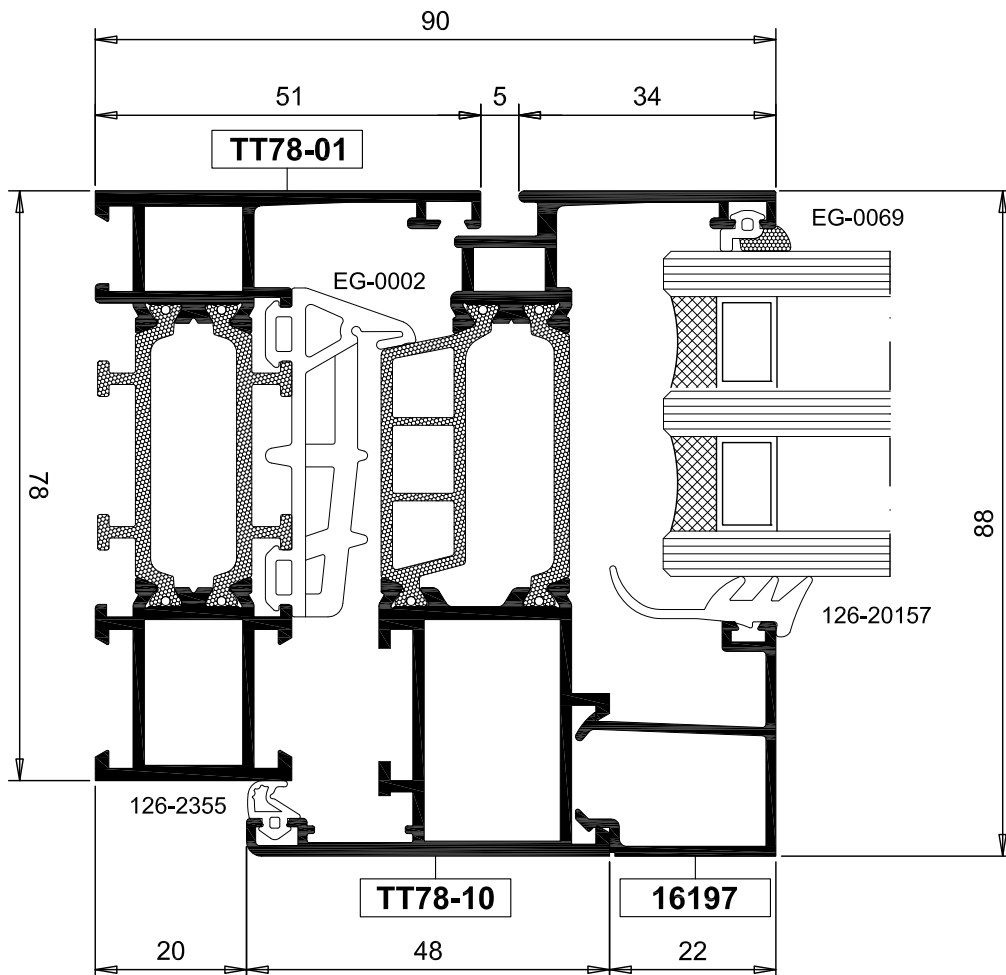
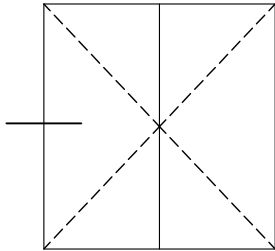

Finestra ad un anta - One wing casement window

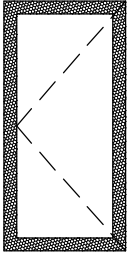

Note:

Notes:

Spessore vetro considerato mm 31

For glass with 31 mm thickness

Gioco perimetrale tra profilo e vetro mm 5 minimo

Space between glass and profile 5 mm minimum



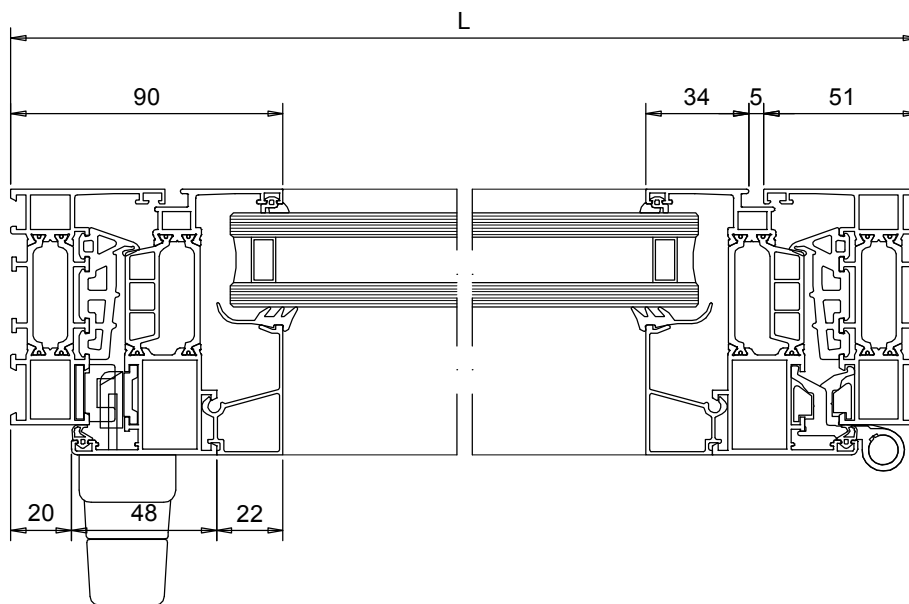
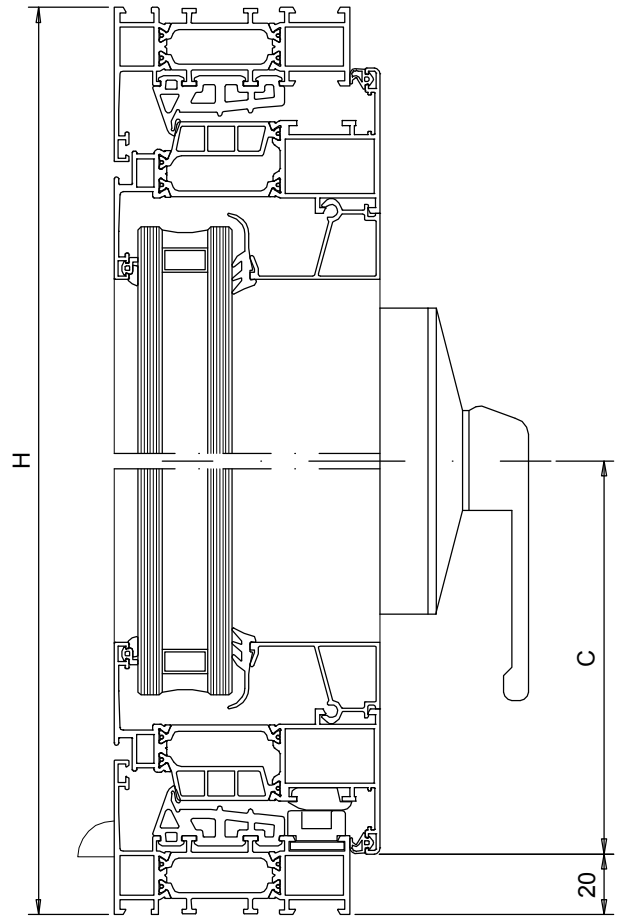

Vetro N° 1 pezzo

Glass N°1 piece

(L-150) (H-150)

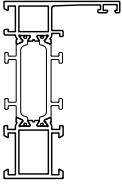

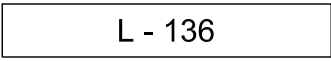
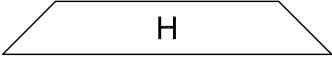
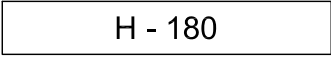
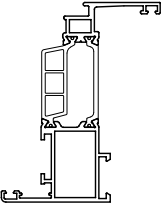
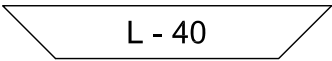
Finestra ad un anta - One wing casement window

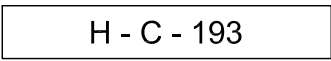
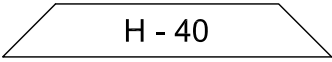
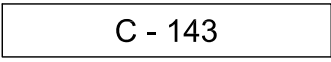
Profilo Profile	N° Pezzi Pcs	Schema di taglio Preparation	Profilo Profile	N° Pezzi Pcs	Schema di taglio Preparation
 TT78-01	2	 L	 24560	2	 L - 136
	2	 H		2	 H - 180
 TT78-10	2	 L - 40	 6405	1	 H - C - 193
	2	 H - 40		1	 C - 143

Per accessori di movimentazione vedere:
Layout pag. 2-13 per peso anta 80 Kg
Layout pag. 2-14 per peso anta 100/130 Kg

Handling accessories:
Layout pag. 2-13 capacity 80 Kg
Layout pag. 2-14 capacity 100/130 Kg

Accessori
Accessories

Accessori
Accessories

Guarnizioni
Gaskets

Art. Item	Descrizione Description	N°pezzi Pcs	Art. Item	Descrizione Description	N°pezzi Pcs	Art. Item	Descrizione Description	N°pezzi Pcs
104-600.01	Espansore Adjustable block	7				126-2355	Guarnizione tenuta esterna External seal gasket	2L 2H
104-RB640	Spessore per espansore Shlm for adjustable block	7				EG-0002	Guarnizione di tenuta centrale Central seal gasket	2L 2H
174-1801	Squadretta a cianfrinare Corner joint locked by crimping	4				EG-0069	Guarnizione di vetro esterna External glass beading gasket	2L 2H
153-0057	Squadretta esterna External corner joint	4				126-20157	Guarnizione di vetro interna Internal glass beading gasket	2L 2H
174-1802	Squadretta a cianfrinare Corner joint locked by crimping	4				EG-0001	Angolo vulcanizzato Vulcanized angle	N° 4 pz
153-0058	Squadretta esterna External corner joint	4				EG-0052	Guarnizione fissaggio fermavetri Gasket for fixing glass beading	N° 12 pz
174-1591	Squadretta allineamento esterna External align. corner joint	8						
153-040.4	Squadretta allin. interno anta Internal wlng align. corner joint	4						
142-2145	Drenaggio acqua Water drainage	2						

Finestra a due ante - two wings casement window

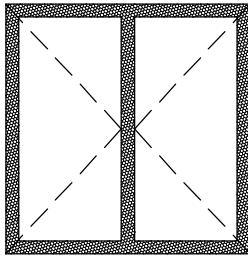

Note:

Notes:

Spessore vetro considerato mm 31

For glass with 31 mm thickness

Gioco perimetrale tra profilo e vetro mm 5 minimo

Space between glass and profile 5 mm minimum

Vetro N° 2 pezzi

Glass N°2 pieces

[(L-265)/2 (H-150)]

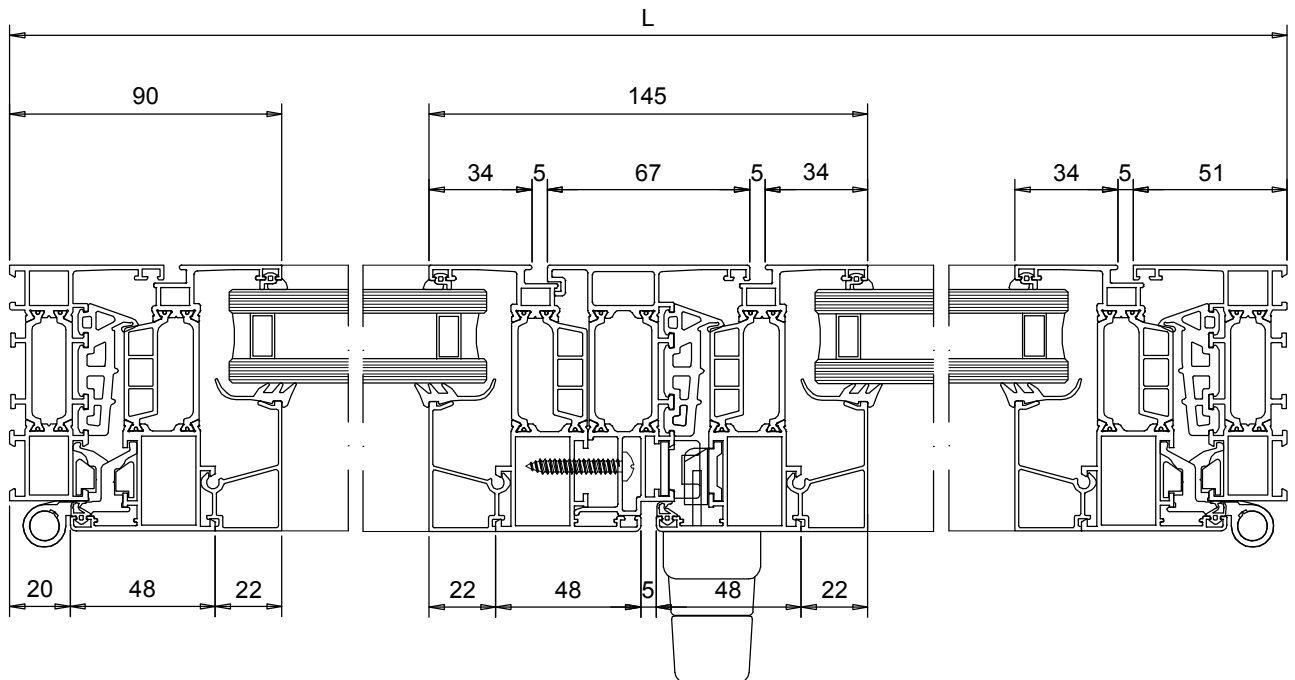
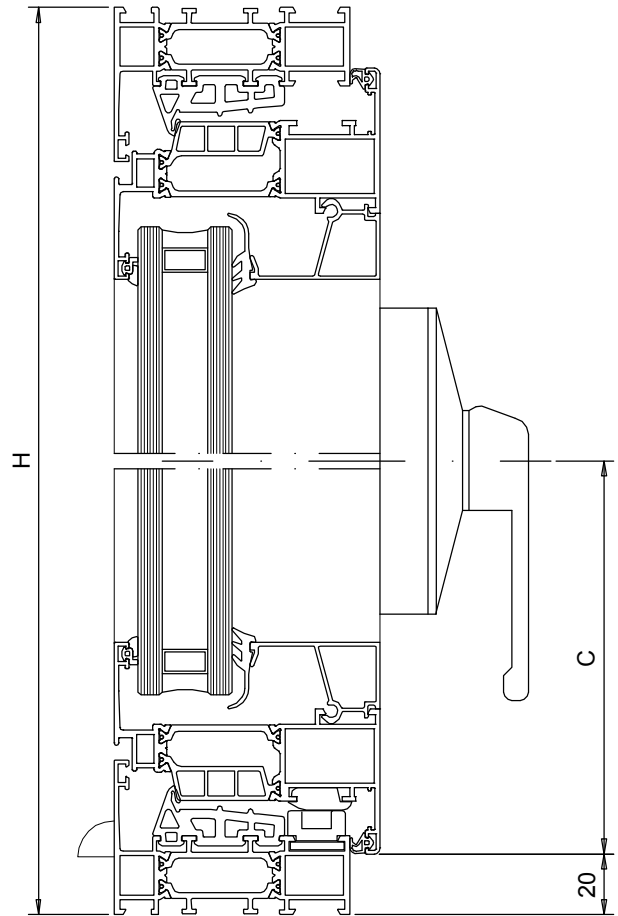

Finestra a tre ante - Three wings casement window

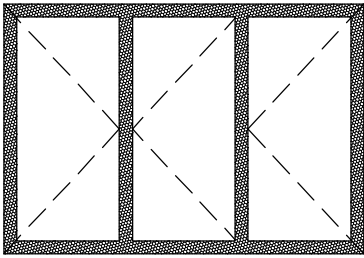

Note:

Notes:

Spessore vetro considerato mm 31

For glass with 31 mm thickness

Gioco perimetrale tra profilo e vetro mm 5 minimo

Space between glass and profile 5 mm minimum



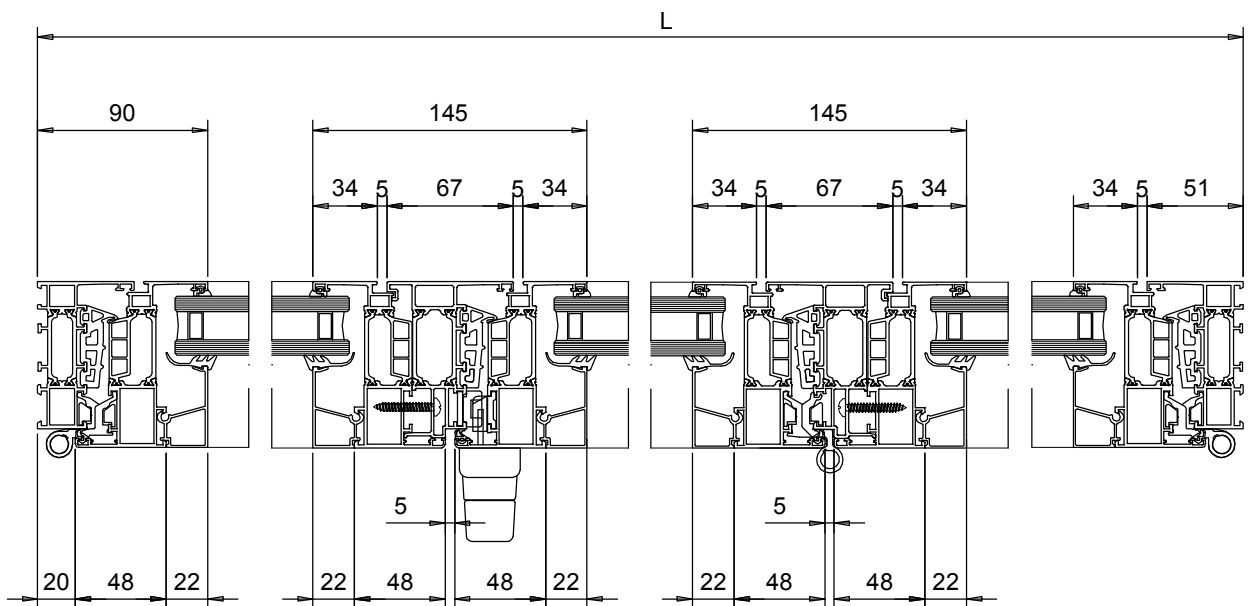
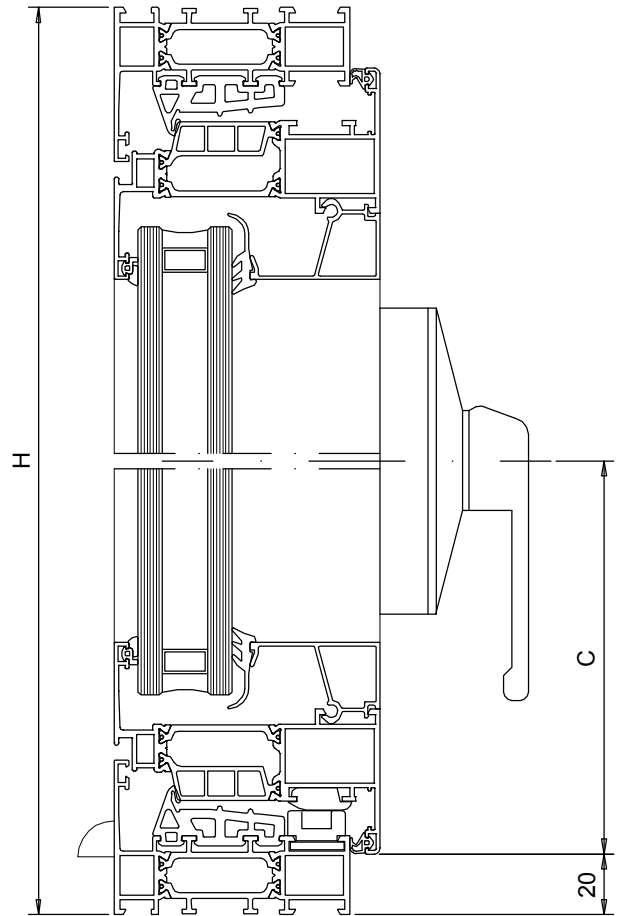

Vetro N° 3 pezzi

Glass N°3 pieces

$$[(L-380)/3 (H-150)]$$

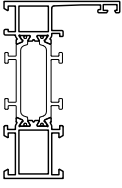

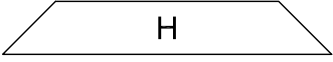
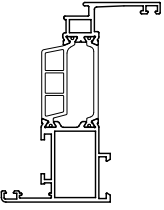
Finestra a tre ante - Three wings casement window

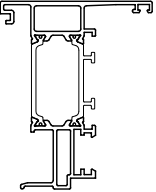
Profilo Profile	N° Pezzi Pcs	Schema di taglio Preparation	Profilo Profile	N° Pezzi Pcs	Schema di taglio Preparation
 TT78-01	2	 L	 24560	6	(L - 338) / 3
	2	 H		6	H - 180
 TT78-10	6	(L - 50) / 3	 6405	1	H - C - 193
	6	H - 40		1	C - 143
 TT78-19	2	H - 112			

Per accessori di movimentazione vedere:
Layout pag. 2-21 per peso anta 80 Kg

Handling accessories:
Layout pag. 2-21 capacity 80 Kg

Accessori
Accessories

Accessori
Accessories

Guarnizioni
Gaskets

Art. Item	Descrizione Description	N°pezzi Pcs	Art. Item	Descrizione Description	N°pezzi Pcs	Art. Item	Descrizione Description	N°pezzi Pcs
104-600.01	Espansore Adjustable block	9				126-2355	Guarnizione tenuta esterna External seal gasket	2L 4H
104-RB640	Spessore per espansore Shlm for adjustable block	9				EG-0002	Guarnizione di tenuta centrale Central seal gasket	2L 4H
174-1801	Squadretta a cianfrinare Corner joint locked by crimping	4				EG-0069	Guarnizione di vetro esterna External glass beading gasket	2L 6H
153-0057	Squadretta esterna External corner joint	4				126-20157	Guarnizione di vetro interna Internal glass beading gasket	2L 6H
174-1802	Squadretta a cianfrinare Corner joint locked by crimping	12				EG-0001	Angolo vulcanizzato Vulcanized angle	N° 4 pz
153-0058	Squadretta esterna External corner joint	12				EG-0052	Guarnizione fissaggio fermavetri Gasket for fixing glass beading	N° 36 pz
174-1591	Squadretta allineamento esterna External align. corner joint	16						
153-040.4	Squadretta allin. interno anta Internal wlng align. corner joint	12						
EA-0039	Tappo riporto centrale Seal plug on central profile	2						
142-2145	Drenaggio acqua Water drainage	4						

Finestra a wasistas - Hopper window

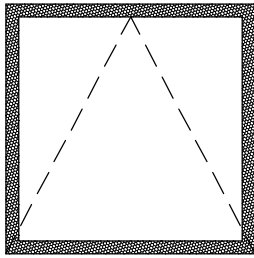

Note:

Notes:

Spessore vetro considerato mm 31

For glass with 31 mm thickness

Gioco perimetrale tra profilo e vetro mm 5 minimo



Space between glass and profile 5 mm minimum

Vetro N° 1 pezzo

Glass N°1 piece

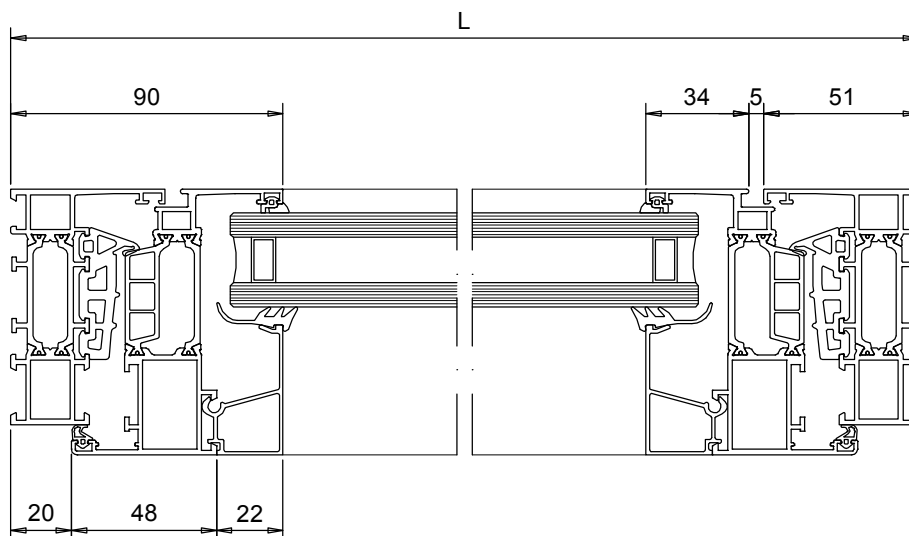
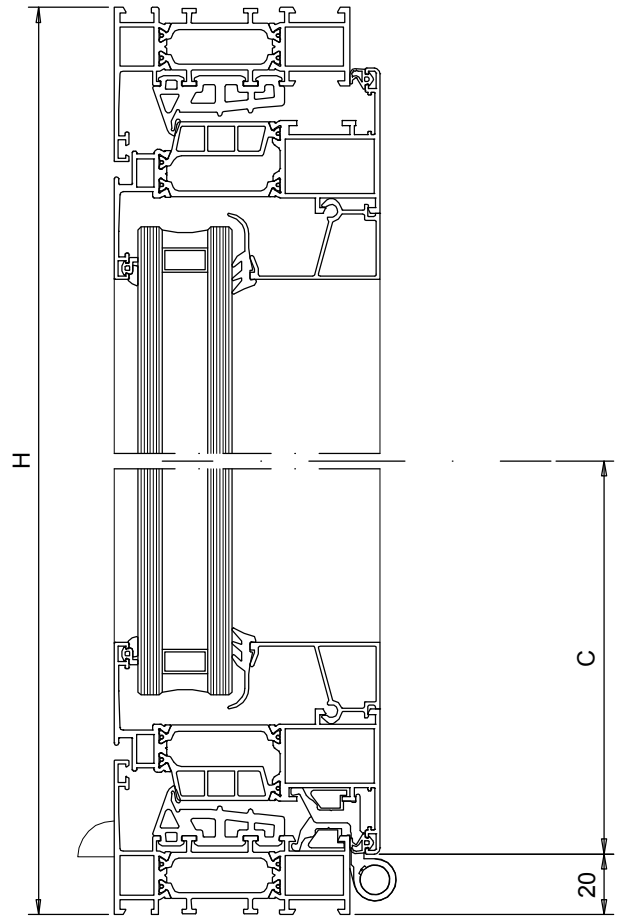
(L-150) (H-150)

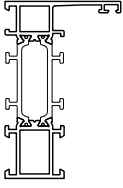

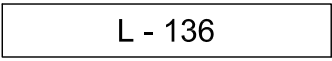
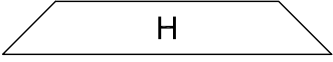
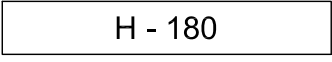
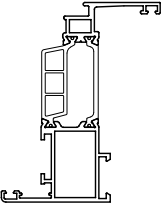
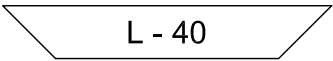
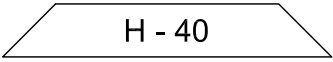
Finestra a wasistas - Hopper window					
Profilo Profile	N° Pezzi Pcs	Schema di taglio Preparation	Profilo Profile	N° Pezzi Pcs	Schema di taglio Preparation
 TT78-01	2	 L	 24560	2	 L - 136
	2	 H		2	 H - 180
 TT78-10	2	 L - 40			
	2	 H - 40			

Per accessori di movimentazione vedere:
Layout pag. 2-22 maniglia verticale peso anta 40/100 Kg
Layout pag. 2-23 maniglia orizzontale peso anta 30/50 Kg

Handling accessories:
Layout pag. 2-22 vertical handle capacity 40/100 Kg
Layout pag. 2-23 horizontal handle capacity 30/50 Kg

Accessori Accessories			Accessori Accessories			Guarnizioni Gaskets		
Art. Item	Descrizione Description	N°pezzi Pcs	Art. Item	Descrizione Description	N°pezzi Pcs	Art. Item	Descrizione Description	N°pezzi Pcs
104-600.01	Espansore Adjustable block	7				126-2355	Guarnizione tenuta esterna External seal gasket	2L 2H
104-RB640	Spessore per espansore Shlm for adjustable block	7				EG-0002	Guarnizione di tenuta centrale Central seal gasket	2L 2H
174-1801	Squadretta a cianfrinare Corner joint locked by crimping	4				EG-0069	Guarnizione di vetro esterna External glass beading gasket	2L 2H
153-0057	Squadretta esterna External corner joint	4				126-20157	Guarnizione di vetro interna Internal glass beading gasket	2L 2H
174-1802	Squadretta a cianfrinare Corner joint locked by crimping	4				EG-0001	Angolo vulcanizzato Vulcanized angle	N° 4 pz
153-0058	Squadretta esterna External corner joint	4				EG-0052	Guarnizione fissaggio fermavetri Gasket for fixing glass beading	N° 12 pz
174-1591	Squadretta allineamento esterna External align. corner joint	8						
153-040.4	Squadretta allin. interno anta Internal wlng align. corner joint	4						
142-2145	Drenaggio acqua Water drainage	2						

Portabalcone ad un anta - One wing balcony door

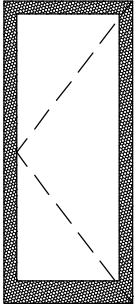

Note:

Notes:

Spessore vetro considerato mm 31

For glass with 31 mm thickness

Gioco perimetrale tra profilo e vetro mm 5 minimo

Space between glass and profile 5 mm minimum

Vetro N° 1 pezzo

Glass N°1 piece

(L-150) (H-200)

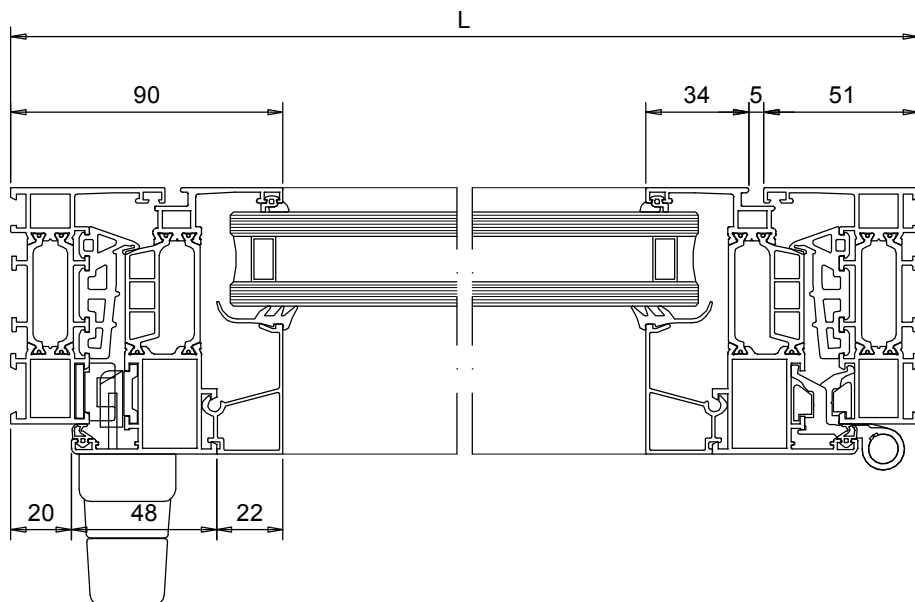
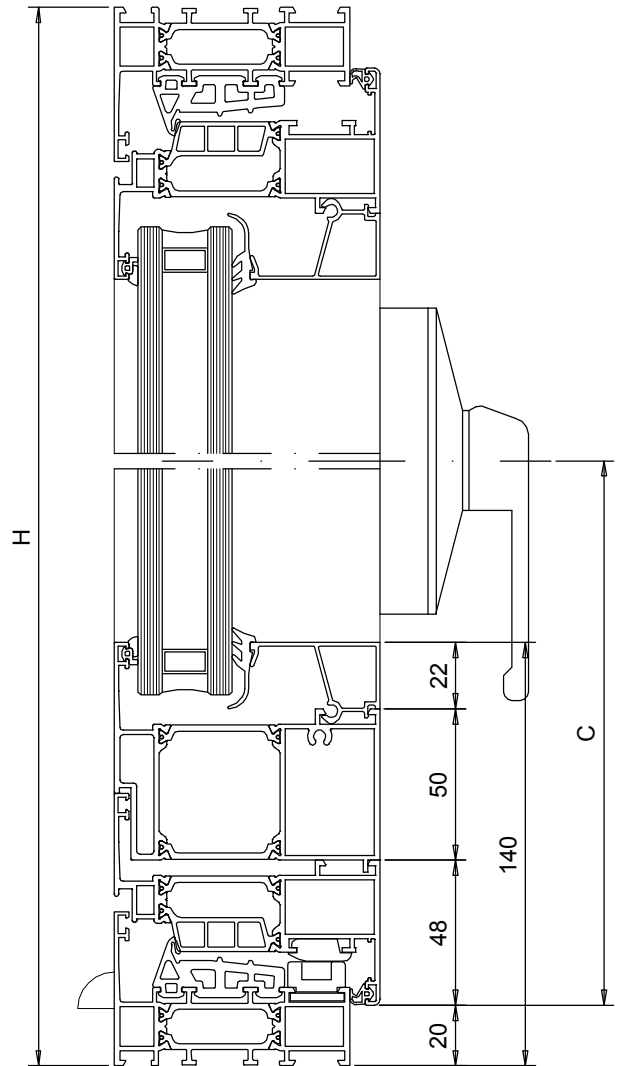

Portabalcone a due ante - two wings balcony door

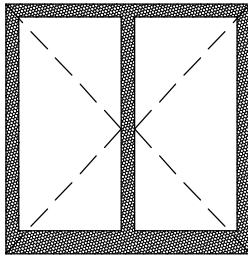

Note:

Notes:

Spessore vetro considerato mm 31

For glass with 31 mm thickness

Gioco perimetrale tra profilo e vetro mm 5 minimo

Space between glass and profile 5 mm minimum

Vetro N° 2 pezzi

Glass N°2 pieces

$[(L-265)/2 (H-200)]$

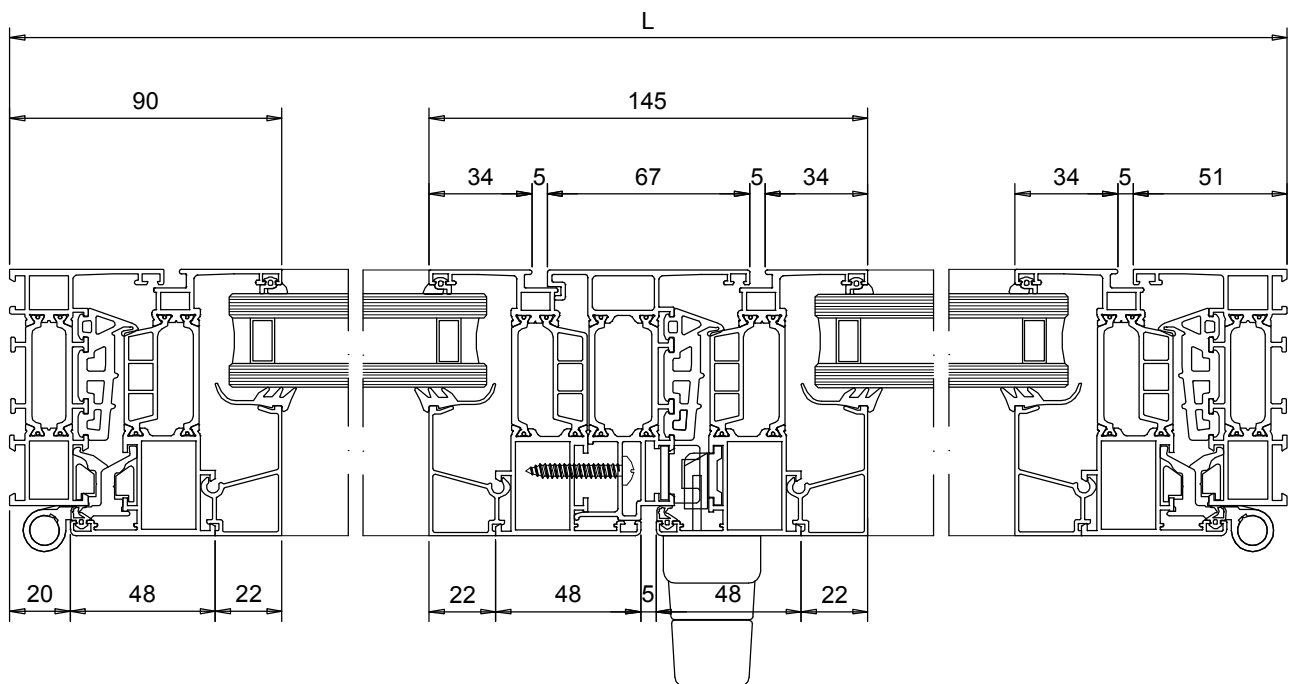
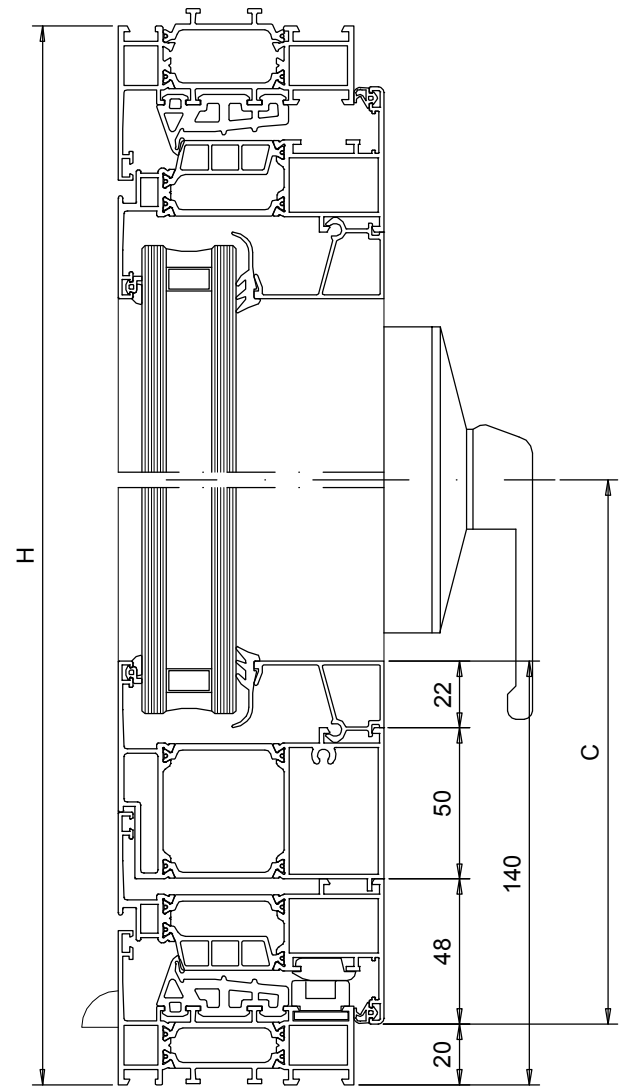

Finestra ad un anta ribalta - One wing with tilt-turn

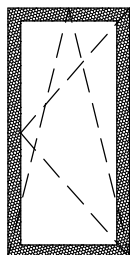

Note:

Notes:

Spessore vetro considerato mm 31

For glass with 31 mm thickness

Gioco perimetrale tra profilo e vetro mm 5 minimo

Space between glass and profile 5 mm minimum



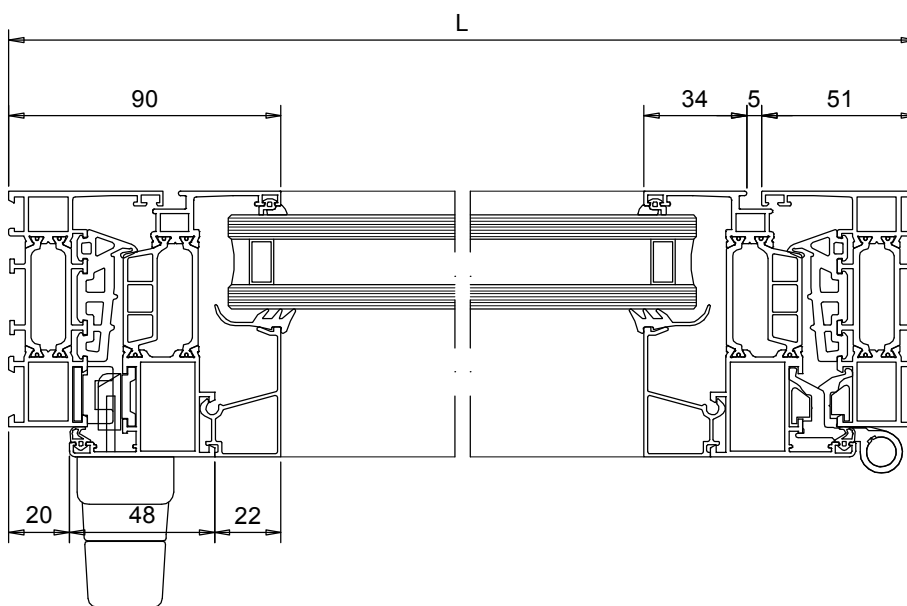
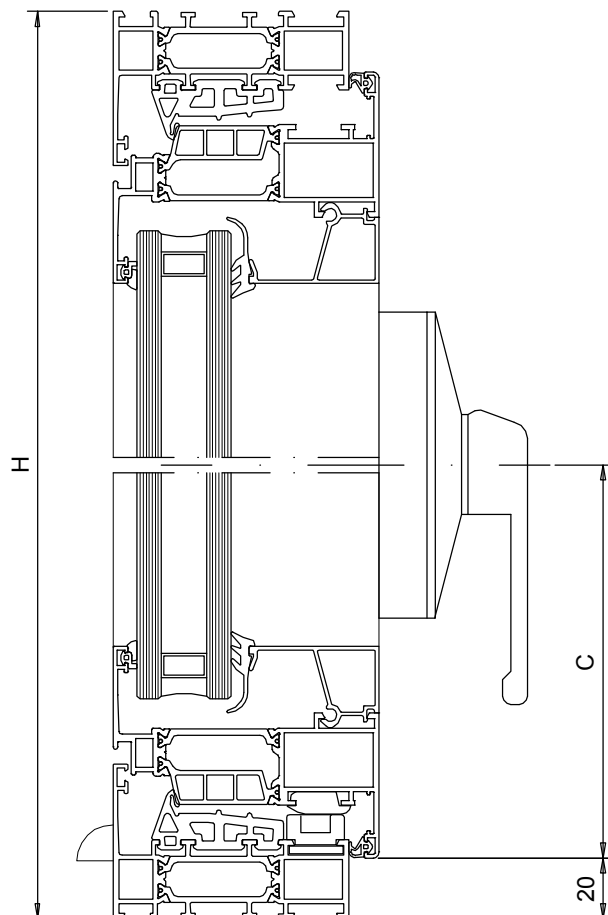

Vetro N° 1 pezzo

Glass N°1 piece

(L-150) (H-150)

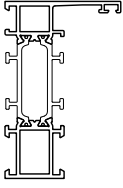

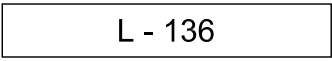
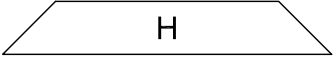
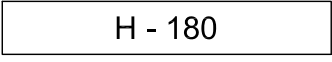
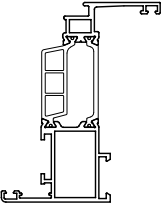
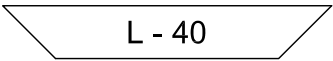
Finestra ad un anta ribalta - One wing with tilt-turn

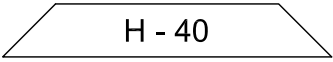
Profilo Profile	N° Pezzi Pcs	Schema di taglio Preparation	Profilo Profile	N° Pezzi Pcs	Schema di taglio Preparation
 TT78-01	2	 L	 24560	2	 L - 136
	2	 H		2	 H - 180
 TT78-10	2	 L - 40	 6405	Per lavorazioni vedi istruzioni nel kit	
	2	 H - 40		For tooling see instructions in the kit	

Per accessori di movimentazione vedere:
Layout pag. 2-15 classica per peso anta 100/130 Kg
Layout pag. 2-16 TBT "Logica" per peso anta 100/130 Kg

Handling accessories:
Layout pag. 2-15 "Classic" capacity 100/130 Kg
Layout pag. 2-16 TBT "Logic" 100/130 Kg

Accessori
Accessories

Accessori
Accessories

Guarnizioni
Gaskets

Art. Item	Descrizione Description	N°pezzi Pcs	Art. Item	Descrizione Description	N°pezzi Pcs	Art. Item	Descrizione Description	N°pezzi Pcs
104-600.01	Espansore Adjustable block	7				126-2355	Guarnizione tenuta esterna External seal gasket	2L 2H
104-RB640	Spessore per espansore Shlm for adjustable block	7				EG-0002	Guarnizione di tenuta centrale Central seal gasket	2L 2H
174-1801	Squadretta a cianfrinare Corner joint locked by crimping	4				EG-0069	Guarnizione di vetro esterna External glass beading gasket	2L 2H
153-0057	Squadretta esterna External corner joint	4				126-20157	Guarnizione di vetro interna Internal glass beading gasket	2L 2H
174-1802	Squadretta a cianfrinare Corner joint locked by crimping	4				EG-0001	Angolo vulcanizzato Vulcanized angle	N° 4 pz
153-0058	Squadretta esterna External corner joint	4				EG-0052	Guarnizione fissaggio fermavetri Gasket for fixing glass beading	N° 12 pz
174-1591	Squadretta allineamento esterna External align. corner joint	8						
153-040.4	Squadretta allin. interno anta Internal wlng align. corner joint	4						
142-2145	Drenaggio acqua Water drainage	2						

Finestra a due ante con anta ribalta - two wings casement window with tilt-turn

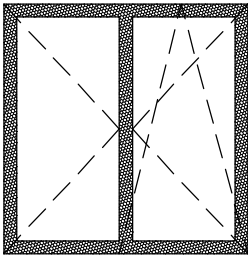

Note:

Notes:

Spessore vetro considerato mm 31

For glass with 31 mm thickness

Gioco perimetrale tra profilo e vetro mm 5 minimo

Space between glass and profile 5 mm minimum

Vetro N° 2 pezzi

Glass N°2 pieces

[(L-265)/2 (H-150)]

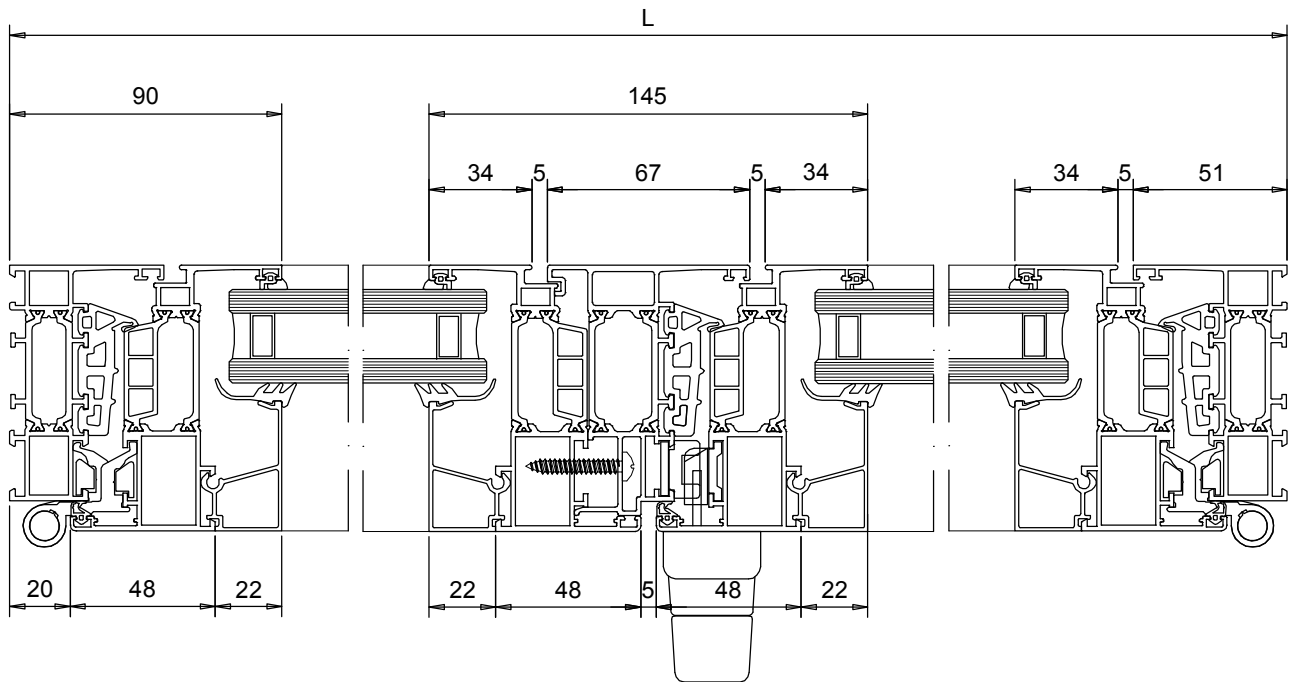
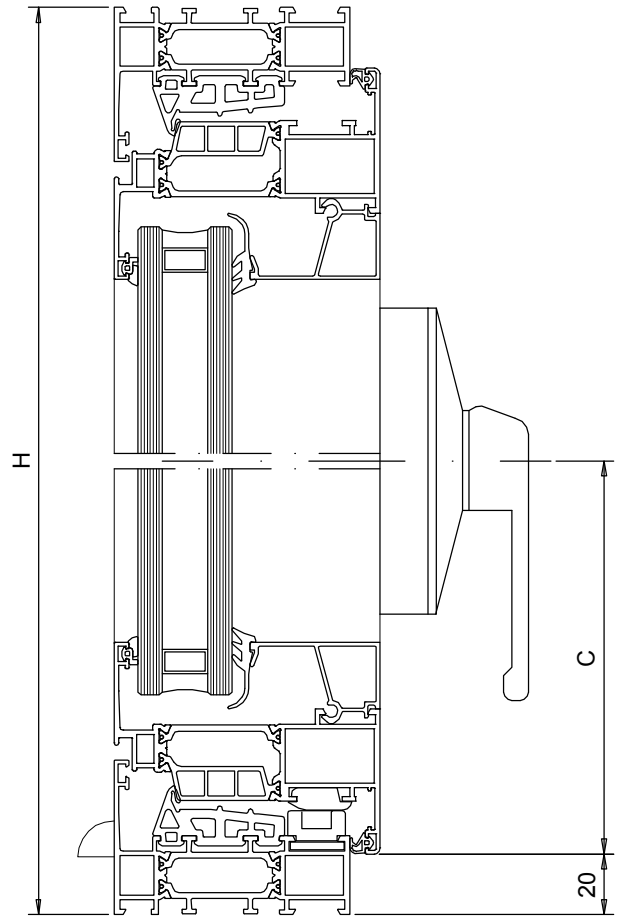

Finestra bilico orizzontale - Horizontal pivoting window

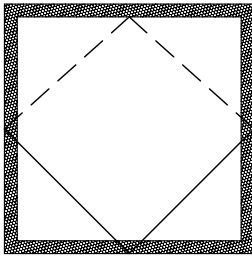

Note:

Notes:

Spessore vetro considerato mm 31

For glass with 31 mm thickness

Gioco perimetrale tra profilo e vetro mm 5 minimo

Space between glass and profile 5 mm minimum



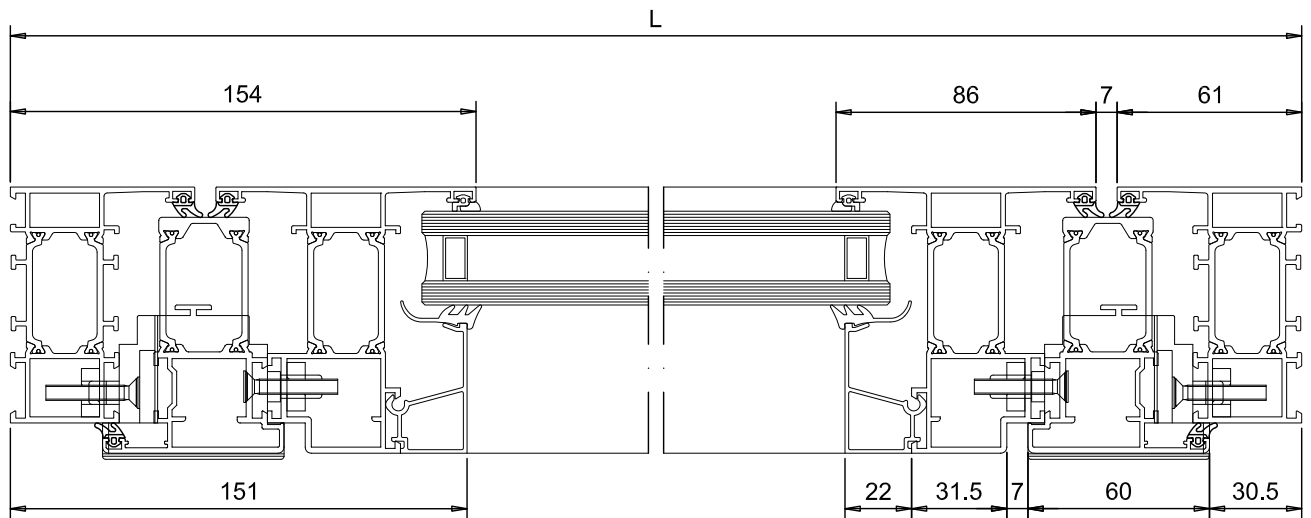
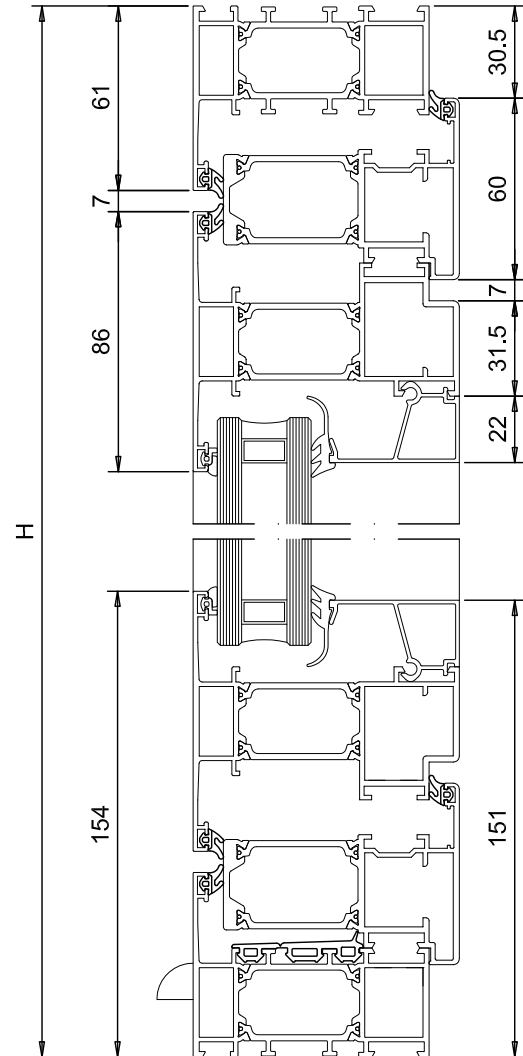

Vetro N° 1 pezzo

Glass N°1 piece

(L-272) (H-272)

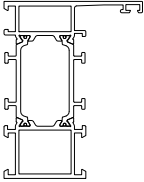

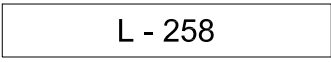
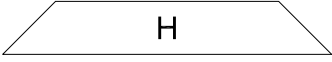
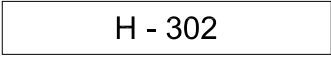
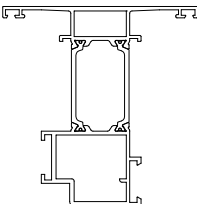
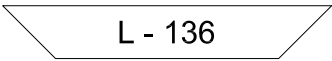

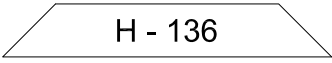
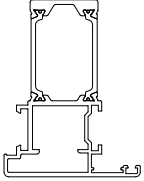
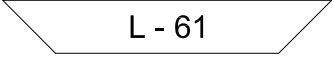
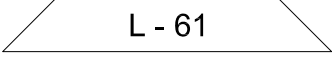
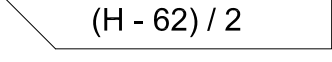
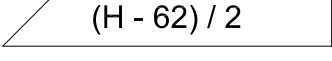
Finestra bilico orizzontale - Horizontal pivoting window

Profilo Profile	N° Pezzi Pcs	Schema di taglio Preparation	Profilo Profile	N° Pezzi Pcs	Schema di taglio Preparation
 TT78-04	2	 L	 24560	2	 L - 258
	2	 H		2	 H - 302
 TT78-44	2	 L - 136	 6405	1	 L
	2	 H - 136			
 TT78-45	1	 L - 61			
	1	 L - 61			
	2	 (H - 62) / 2			
	2	 (H - 62) / 2			

Accessori Accessories			Accessori Accessories			Guarnizioni Gaskets		
Art. Item	Descrizione Description	N°pezzi Pcs	Art. Item	Descrizione Description	N°pezzi Pcs	Art. Item	Descrizione Description	N°pezzi Pcs
104-600.01	Espansore Adjustable block	7	EA-0009	Chiusura intermedia Intermediate lock	1	EG-0061	Guarnizione tenuta esterna External seal gasket	6L 6H
104-RB660	Spessore per espansore Shlm for adjustable block	7	EA-0033	Coppia frizioni per bilico Friction joint for pivot	1	EG-0069	Guarnizione di vetro esterna External glass beading gasket	2L 2H
174-1803	Squadretta a cianfrinare Corner joint locked by crimping	8	EA-0034	Movimentazione aperture bilico Mill-in gear	1	126-20157	Guarnizione di vetro interna Internal glass beading gasket	2L 2H
153-0059	Squadretta esterna External corner joint	8	EA-0035	Incontro registrabile Adjustable locking plate	3	EG-0060	Guarnizione tenuta bilico Seal gasket for pivot	1L 2H/2
174-1805	Squadretta a cianfrinare Corner joint locked by crimping	4	EA-0036	Incontro Locking plate	3	EG-0052	Guarnizione fissaggio fermavetri Gasket for fixing glass beading	N° 12 pz
174-1591	Squadretta allineamento esterna External align. corner joint	8						
153-040.4	Squadretta allin. interno anta Internal wing align. corner joint	4						
EA-0018	Martellina Handle	1						
EA-0059	Terminale aste Rod terminal	1						
EA-0060	Kit chiusura perimetrale Perimetric lock Kit	1						

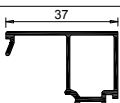
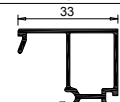
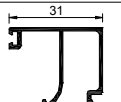
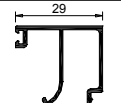
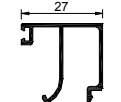
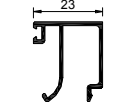
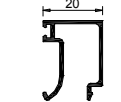
Schema vetratura telaio - Fixed frame glazing diagram

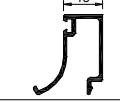
Spessore vetro	Guarnizione interna	Larghezza fermavetro	Tipologie fermavetro			
24	B	37	24557		*	
25	B					
26	A					
27	A					
28	B	33	24556		*	
29	B					
30	B	31	16197		24528	*
31	B					
32	A					
33	A					
32	B	29	16195		24573	*
33	B					
34	B	27	16193		24572	*
35	B					
36	A					
37	A					
38	B	23	16191		24571	*
39	B					
40	A					
41	A					
41	B	20	22618		24570	*
42	B					
43	A					
44	A					
44	B	17	16189		24569	*
45	B					
46	A					
47	A	15	19712		24568	*
46	B					
47	B	13	16186		24567	*
48	B					
49	B					
50	A					
51	A					

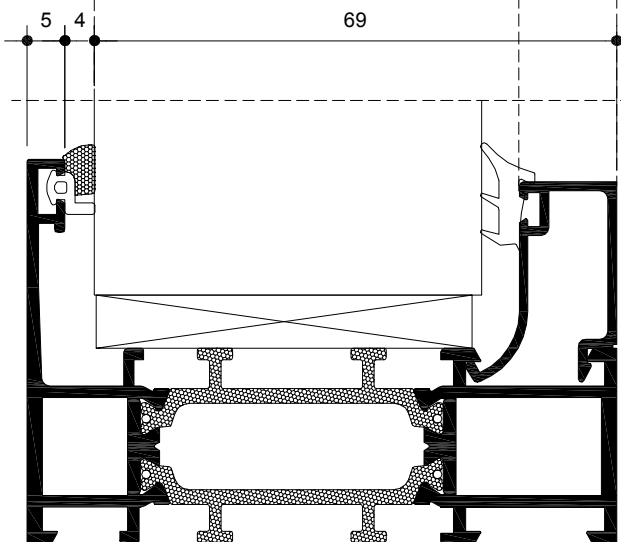

EG-0069

Guarnizione esterna da 4 mm



126-2195

Guarnizione interna da 5+6 mm



126-2197

Guarnizione interna da 7+8 mm

* Questi fermavetri vanno utilizzati con la guarnizione EG-0052
Campi utilizzo:
- inferiore a 1000mm → 2 pezzi
- tra 100mm e 2000mm → 3 pezzi
- tra 2000mm e 3000mm → 4 pezzi
Confezione sacchetti da 100pz. di lunghezza 50mm

Le tabelle per la vetratura sono state realizzate considerando le quote nominali. Le dimensioni reali della vetratura e dei profili, dipendenti dalle tolleranze di produzione, devono essere sempre verificate. Una differente scelta della guarnizione cingivetro interna puo' correggere l'eventuale discordanza tra quote nominali e reali.

Schema vetratura telaio - Fixed frame glazing diagram

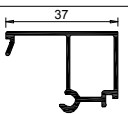
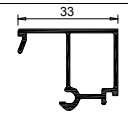
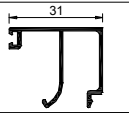
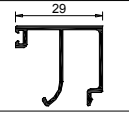
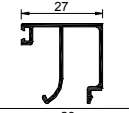
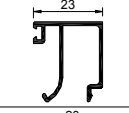
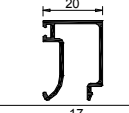
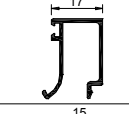
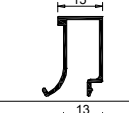
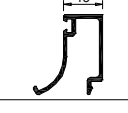
Spessore vetro	Guarnizione interna	Larghezza fermavetro	Tipologie fermavetro			
25	A	37	24557		*	
26	A					
29	A	33	24556		*	
30	A					
31	A	31	16197		24528	*
32	A					
33	A	29	16195		24573	*
34	A					
35	A	27	16193		24572	*
36	A					
39	A	23	16191		24571	*
40	A					
42	A	20	22618		24570	*
43	A					
45	A	17	16189		24569	*
46	A					
47	A	15	19712		24568	*
48	A					
49	A	13	16186		24567	*
50	A					

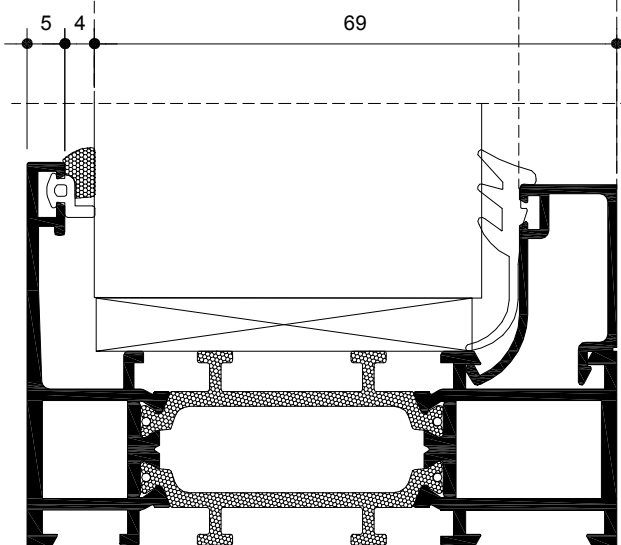

EG-0069

Guarnizione esterna da 4 mm

* Questi fermavetri vanno utilizzati con la guarnizione EG-0052
Campi utilizzo:
- inferiore a 1000mm → 2 pezzi
- tra 1000mm e 2000mm → 3 pezzi
- tra 2000mm e 3000mm → 4 pezzi
Confezione sacchetti da 100pz. di lunghezza 50mm



126-20157

Guarnizione interna da 6÷7 mm

Le tabelle per la vetratura sono state realizzate considerando le quote nominali. Le dimensioni reali della vetratura e dei profili, dipendenti dalle tolleranze di produzione, devono essere sempre verificate. Una differente scelta della guarnizione cingivetro interna puo' correggere l'eventuale discordanza tra quote nominali e reali.

Schema vetrazione anta - Wing glazing diagram

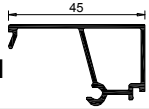
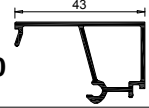
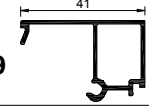
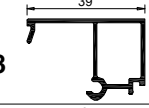
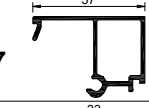
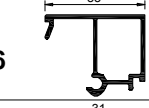
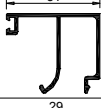
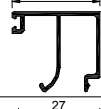
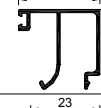
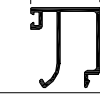
Spessore vetro		Guarnizione interna	Larghezza fermavetro	Tipologie fermavetro		
27	26	B	45	24561		*
28	27	B				
29	28	B	43	24560		*
30	29	B				
31	30	A				
32	31	A				
31	30	B	41	24559		*
32	31	B				
33	32	B	39	24558		*
34	33	B				
35	34	B	37	24557		*
36	35	B				
37	36	A				
38	37	A				
39	38	B	33	24556		*
40	39	B				
41	40	B	31	16197		*
42	41	B				
43	42	B	29	16195		*
44	43	B				
45	44	B	27	16193		*
46	45	B				
47	46	A				
48	47	A				
49	48	B	23	16191		*
50	49	B				
51	50	A				
52	51	A				

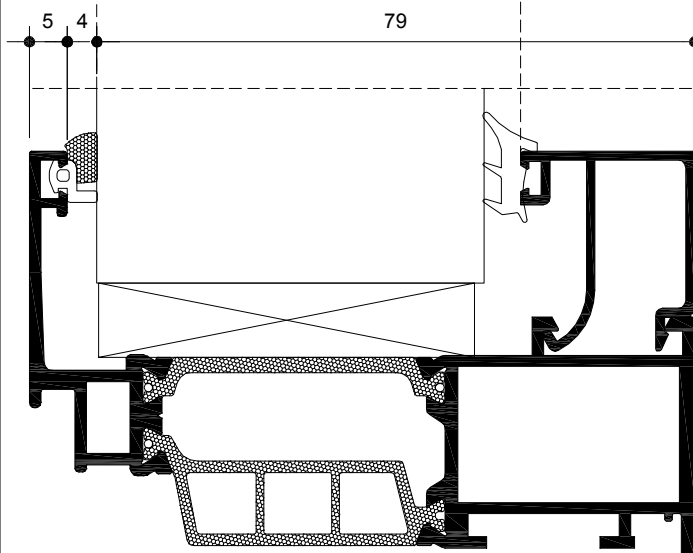

EG-0069
Guarnizione esterna da 4 mm

126-2195
A
Guarnizione interna da 5+6 mm

126-2197
B
Guarnizione interna da 7+8 mm

* Questi fermavetri vanno utilizzati con la guarnizione EG-0052
Campi utilizzo:
- inferiore a 1000mm → 2 pezzi
- tra 1000mm e 2000mm → 3 pezzi
- tra 2000mm e 3000mm → 4 pezzi
Confezione sacchetti da 100pz. di lunghezza 50mm

Le tabelle per la vetrazione sono state realizzate considerando le quote nominali. Le dimensioni reali della vetrazione e dei profili, dipendenti dalle tolleranze di produzione, devono essere sempre verificate. Una differente scelta della guarnizione cingivetro interna puo' correggere l'eventuale discordanza tra quote nominali e reali.

Schema vetrazione anta - Wing glazing diagram

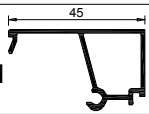
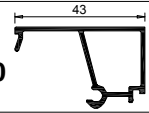
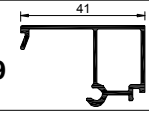
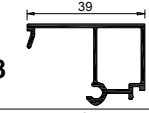
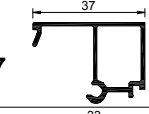
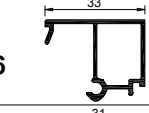
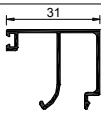
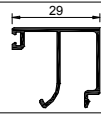
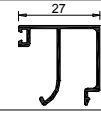
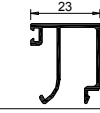
Spessore vetro	Guarnizione interna	Larghezza fermavetro	Tipologie fermavetro			
27	A	45	24561		*	
28	A					
29	A	43	24560		*	
30	A					
31	A	41	24559		*	
32	A					
33	A	39	24558		*	
34	A					
35	A	37	24557		*	
36	A					
39	A	33	24556		*	
40	A					
41	A	31	16197		24528	*
42	A					
43	A	29	16195		24573	*
44	A					
45	A	27	16193		24572	*
46	A					
49	A	23	16191		24571	*
50	A					

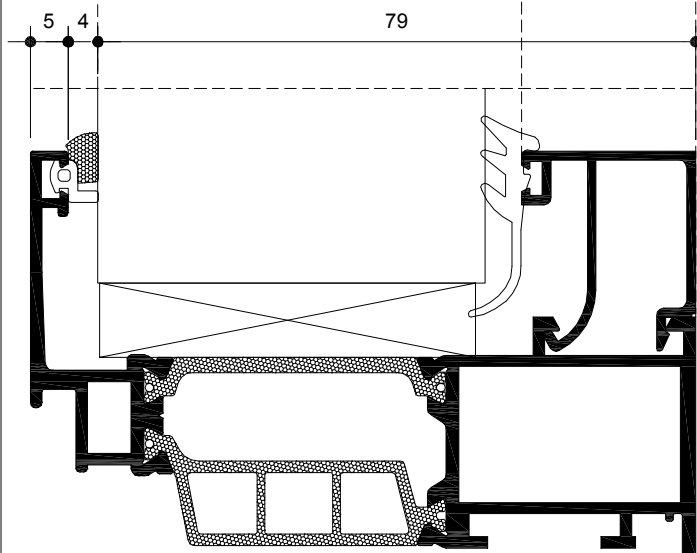

EG-0069

Guarnizione esterna da 4 mm

- * Questi fermavetri vanno utilizzati con la guarnizione EG-0052
Campi utilizzo:
- inferiore a 1000mm → 2 pezzi
- tra 1000mm e 2000mm → 3 pezzi
- tra 2000mm e 3000mm → 4 pezzi
Confezione sacchetti da 100pz. di lunghezza 50mm



126-20157

Guarnizione interna da 6÷7 mm

Le tabelle per la vetrazione sono state realizzate considerando le quote nominali. Le dimensioni reali della vetrazione e dei profili, dipendenti dalle tolleranze di produzione, devono essere sempre verificate. Una differente scelta della guarnizione cingivetro interna puo' correggere l'eventuale discordanza tra quote nominali e reali.

Schema vetrazione anta - Wing glazing diagram

Spessore vetro	Guarnizione interna	Larghezza fermavetro	Tipologie fermavetro			
24	B	37	24557		*	
25	B					
26	A					
27	A					
28	B	33	24556		*	
29	B					
30	B	31	16197		24528	*
31	B					
32	A					
33	A					
32	B	29	16195		24573	*
33	B					
34	B	27	16193		24572	*
35	B					
36	A					
37	A					
38	B	23	16191		24571	*
39	B					
40	A					
41	A					
41	B	20	22618		24570	*
42	B					
43	A					
44	A					
44	B	17	16189		24569	*
45	B					
46	A					
47	A					
46	B	15	19712		24568	*
47	B					
48	B	13	16186		24567	*
49	B					
50	A					
51	A					

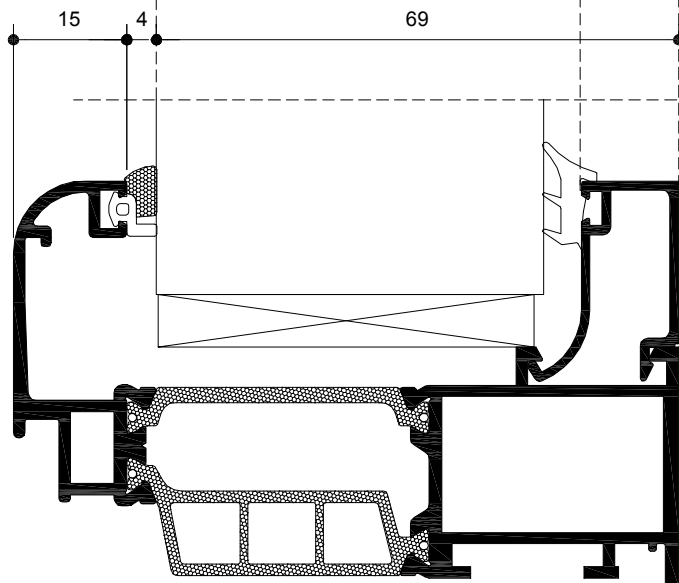

EG-0069

Guarnizione esterna da 4 mm



126-2195

A
Guarnizione interna da 5+6 mm

- * Questi fermavetri vanno utilizzati con la guarnizione EG-0052
Campi utilizzo:
- inferiore a 1000mm → 2 pezzi
- tra 1000mm e 2000mm → 3 pezzi
- tra 2000mm e 3000mm → 4 pezzi
Confezione sacchetti da 100pz. di lunghezza 50mm



126-2197

B
Guarnizione interna da 7+8 mm

Le tabelle per la vetrazione sono state realizzate considerando le quote nominali. Le dimensioni reali della vetrazione e dei profili, dipendenti dalle tolleranze di produzione, devono essere sempre verificate. Una differente scelta della guarnizione cingivetro interna puo' correggere l'eventuale discordanza tra quote nominali e reali.

Schema vetrazione anta - Wing glazing diagram

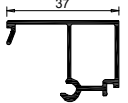
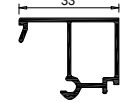
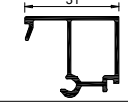
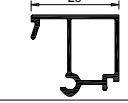
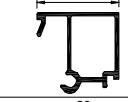
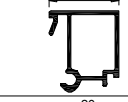
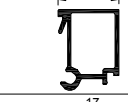
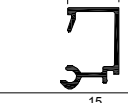
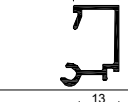
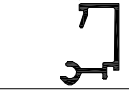
Spessore vetro	Guarnizione interna	Larghezza fermavetro	Tipologie fermavetro		
25	A	37			*
26	A		24557		
29	A	33			*
30	A		24556		
31	A	31			*
32	A		16197	24528	
33	A	29			*
34	A		16195	24573	
35	A	27			*
36	A		16193	24572	
39	A	23			*
40	A		16191	24571	
42	A	20			*
43	A		22618	24570	
45	A	17			*
46	A		16189	24569	
47	A	15			*
48	A		19712	24568	
49	A	13			*
50	A		16186	24567	

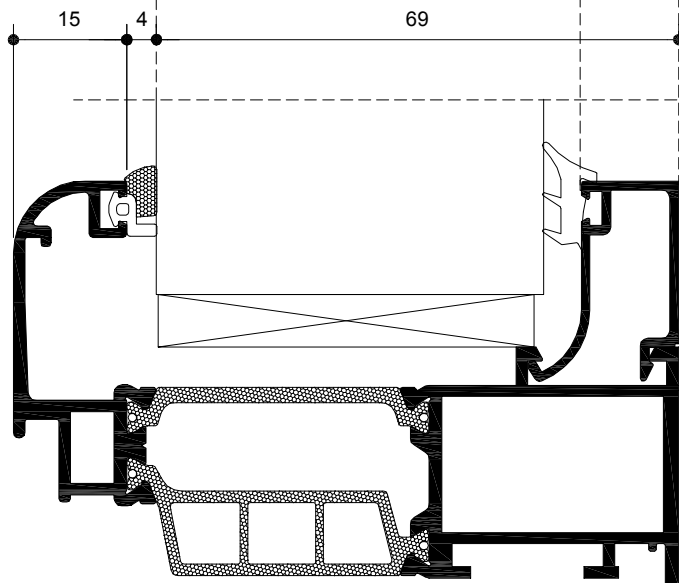

EG-0069

Guarnizione esterna da 4 mm

- * Questi fermavetri vanno utilizzati con la guarnizione EG-0052
Campi utilizzo:
- inferiore a 1000mm → 2 pezzi
- tra 1000mm e 2000mm → 3 pezzi
- tra 2000mm e 3000mm → 4 pezzi
Confezione sacchetti da 100pz. di lunghezza 50mm



126-20157

Guarnizione interna da 6÷7 mm

Le tabelle per la vetrazione sono state realizzate considerando le quote nominali. Le dimensioni reali della vetrazione e dei profili, dipendenti dalle tolleranze di produzione, devono essere sempre verificate. Una differente scelta della guarnizione cingivetro interna puo' correggere l'eventuale discordanza tra quote nominali e reali.

Lavorazioni - Tooling

**LAVORAZIONE PER SQUADRETTA
A SPINARE PER TELAI FISSI**

*** Foro opzionale per incollaggio**

**TOOLING FOR INSTALLING
PINNING CORNER JOINT
FOR FIXED FRAMES**

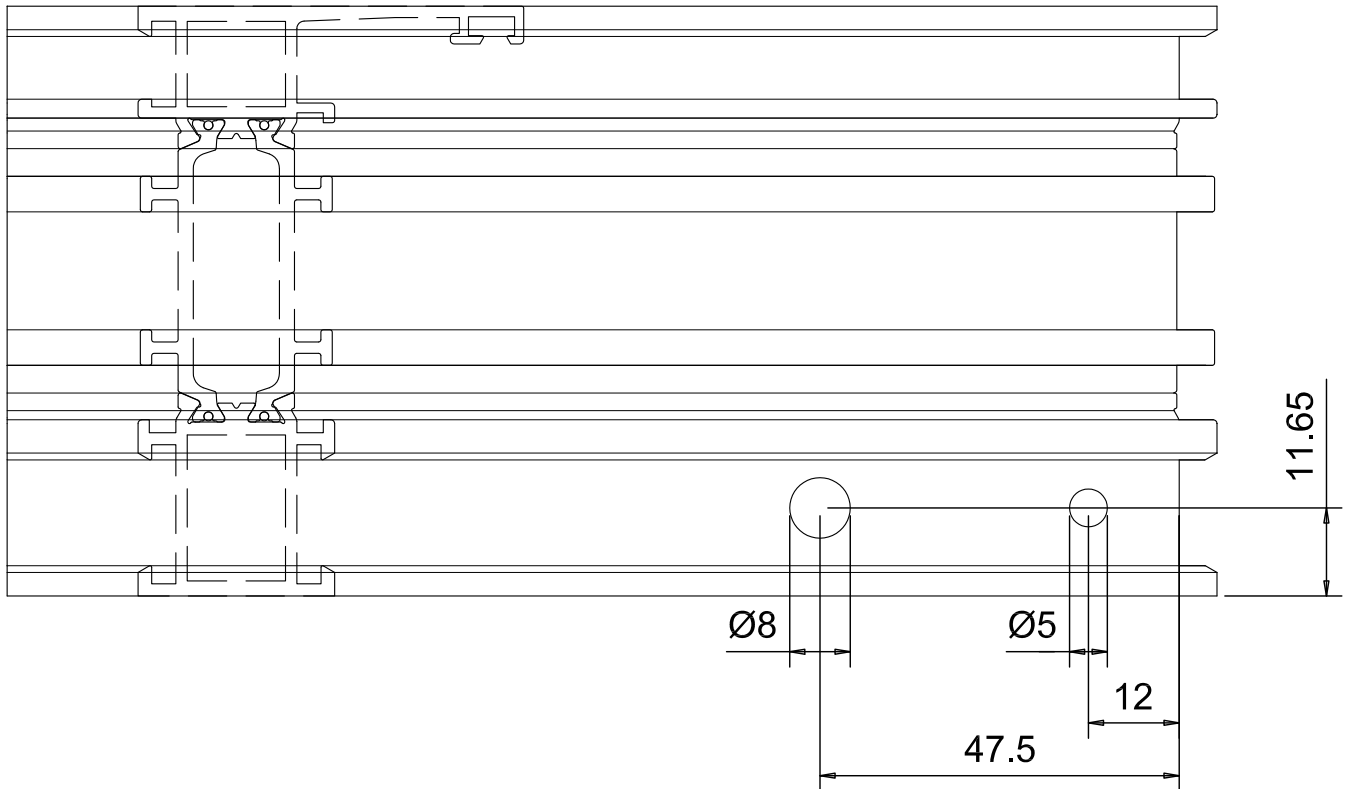
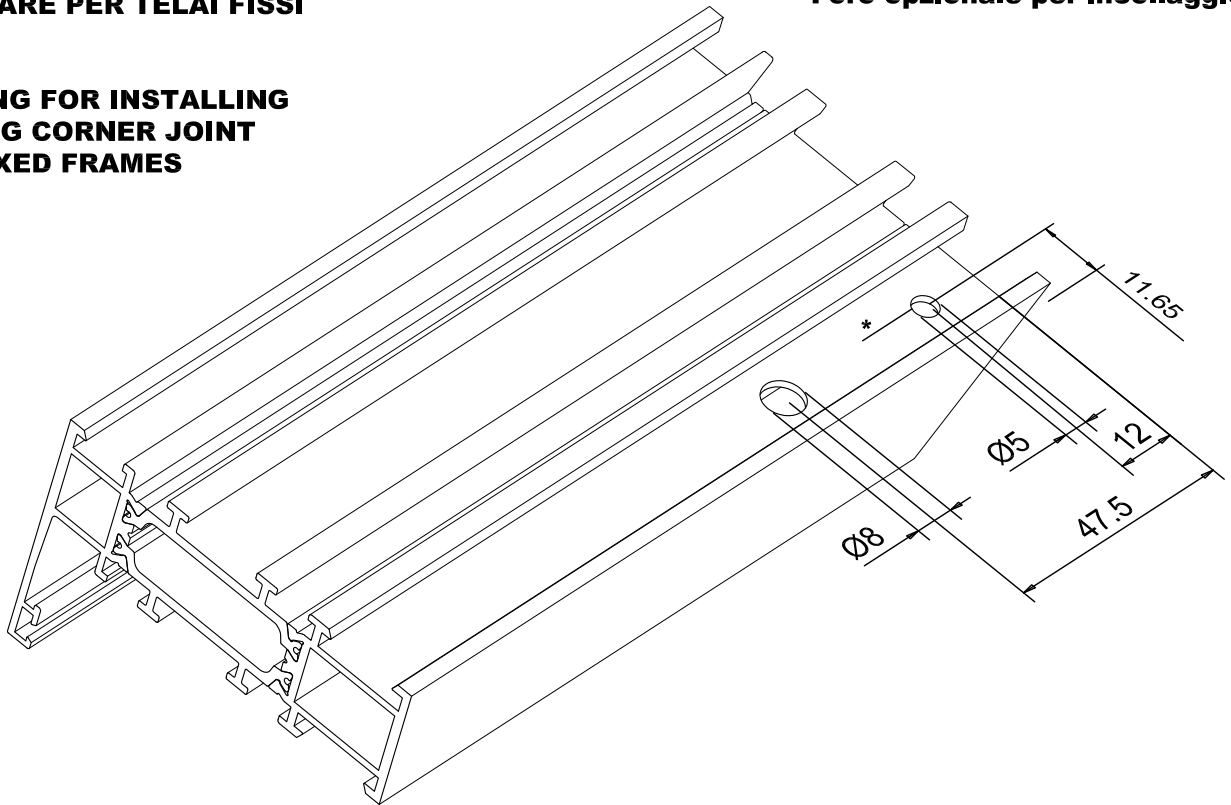

Lavorazioni - Tooling

**LAVORAZIONE PER SQUADRETTA
A SPINARE PER TELAI FISSI**

**TOOLING FOR INSTALLING
PINNING CORNER JOINT
FOR FIXED FRAMES**

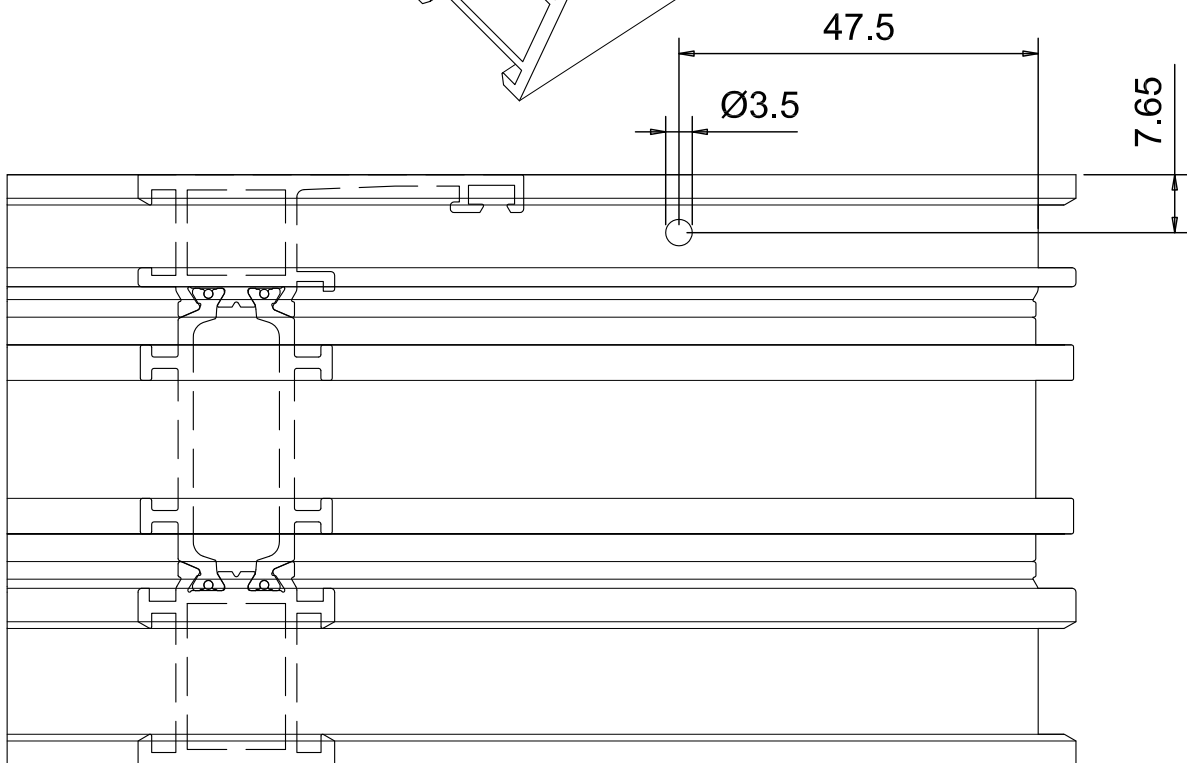
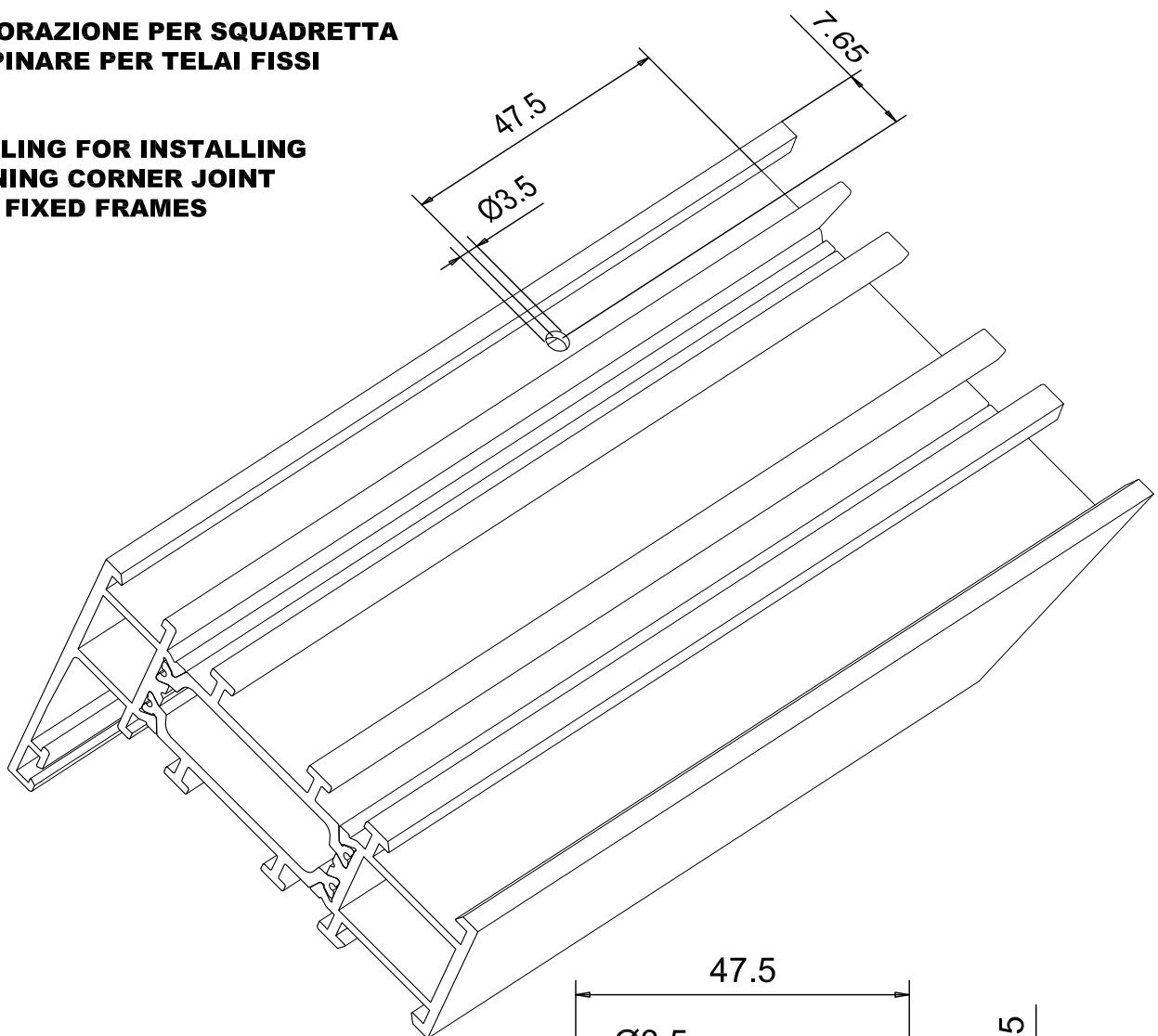

Lavorazioni - Tooling

**LAVORAZIONE PER SQUADRETTA
A SPINARE PER ANTE**

*** Foro opzionale per incollaggio**

**TOOLING FOR INSTALLING
PINNING CORNER JOINT
FOR WINGS**

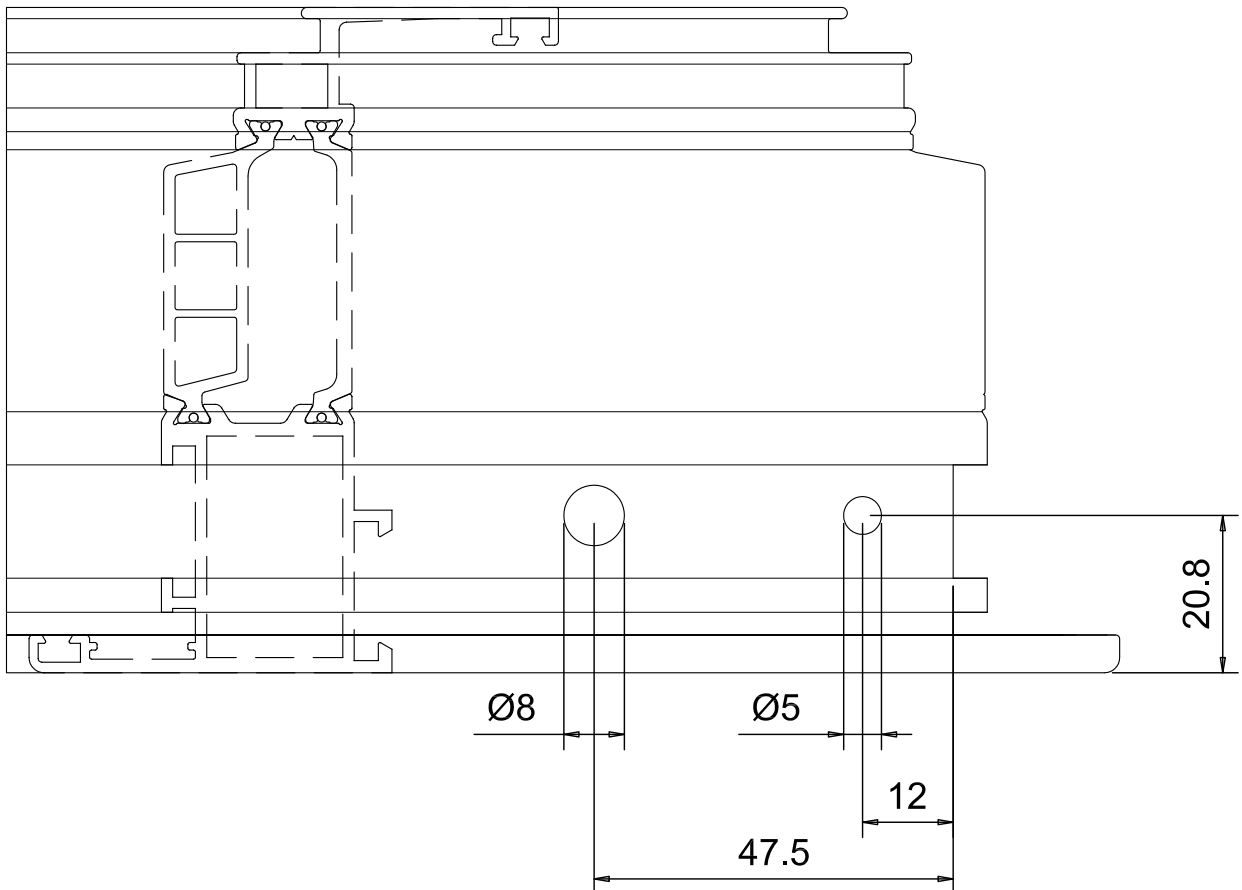
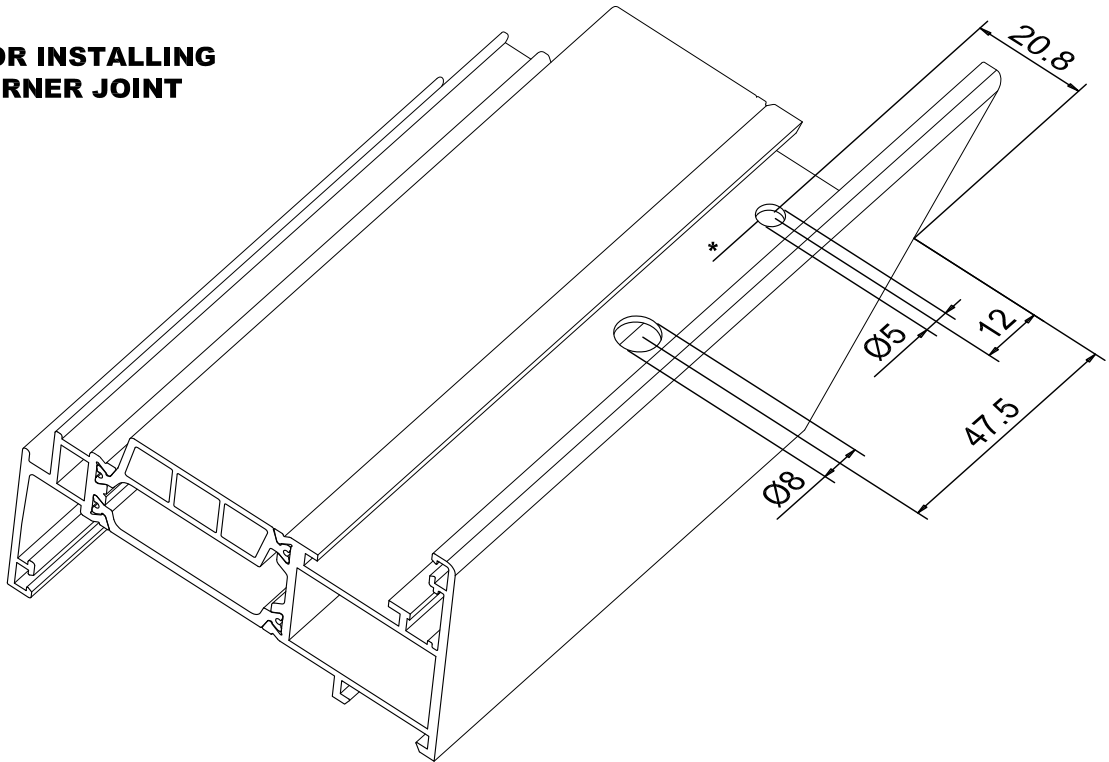

Lavorazioni - Tooling

**LAVORAZIONE PER SQUADRETTA
A SPINARE PER ANTE**

**TOOLING FOR INSTALLING
PINNING CORNER JOINT
FOR WINGS**

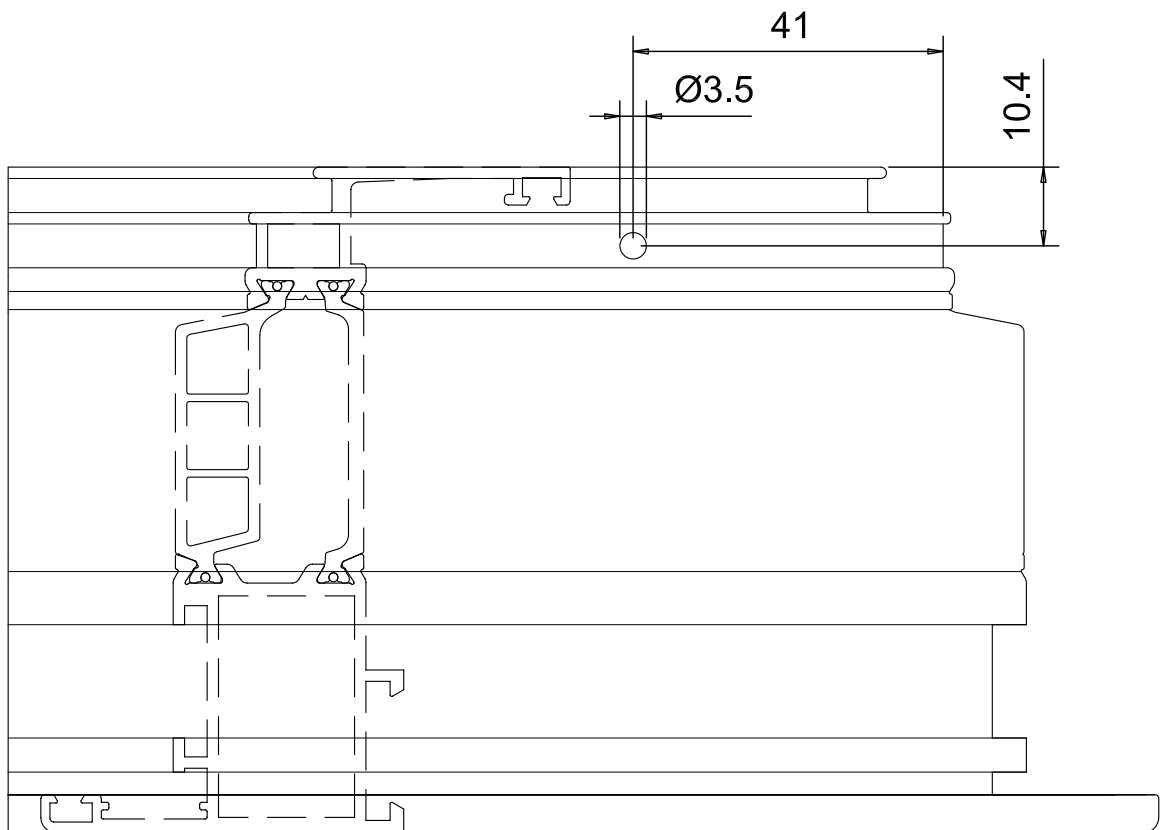
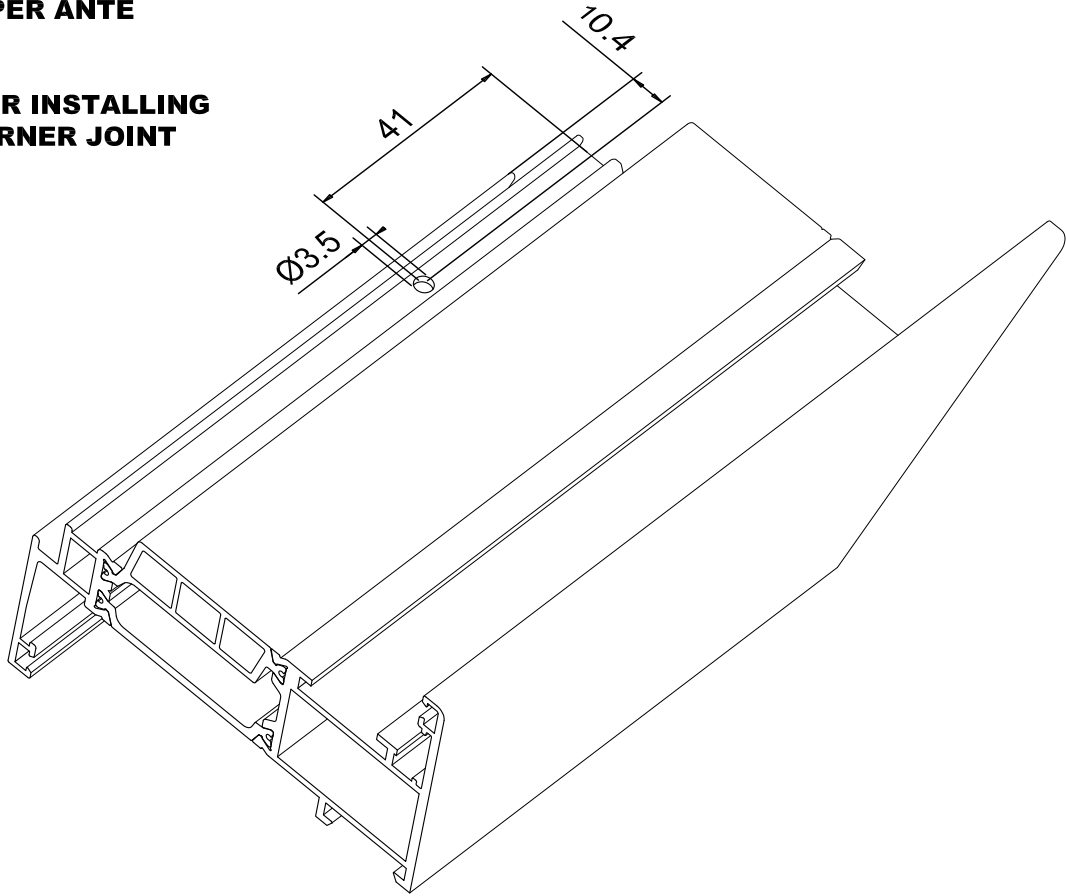

Lavorazioni - Tooling

LAVORAZIONE PER CREMONESE

CREMONE BOLT TOOLING

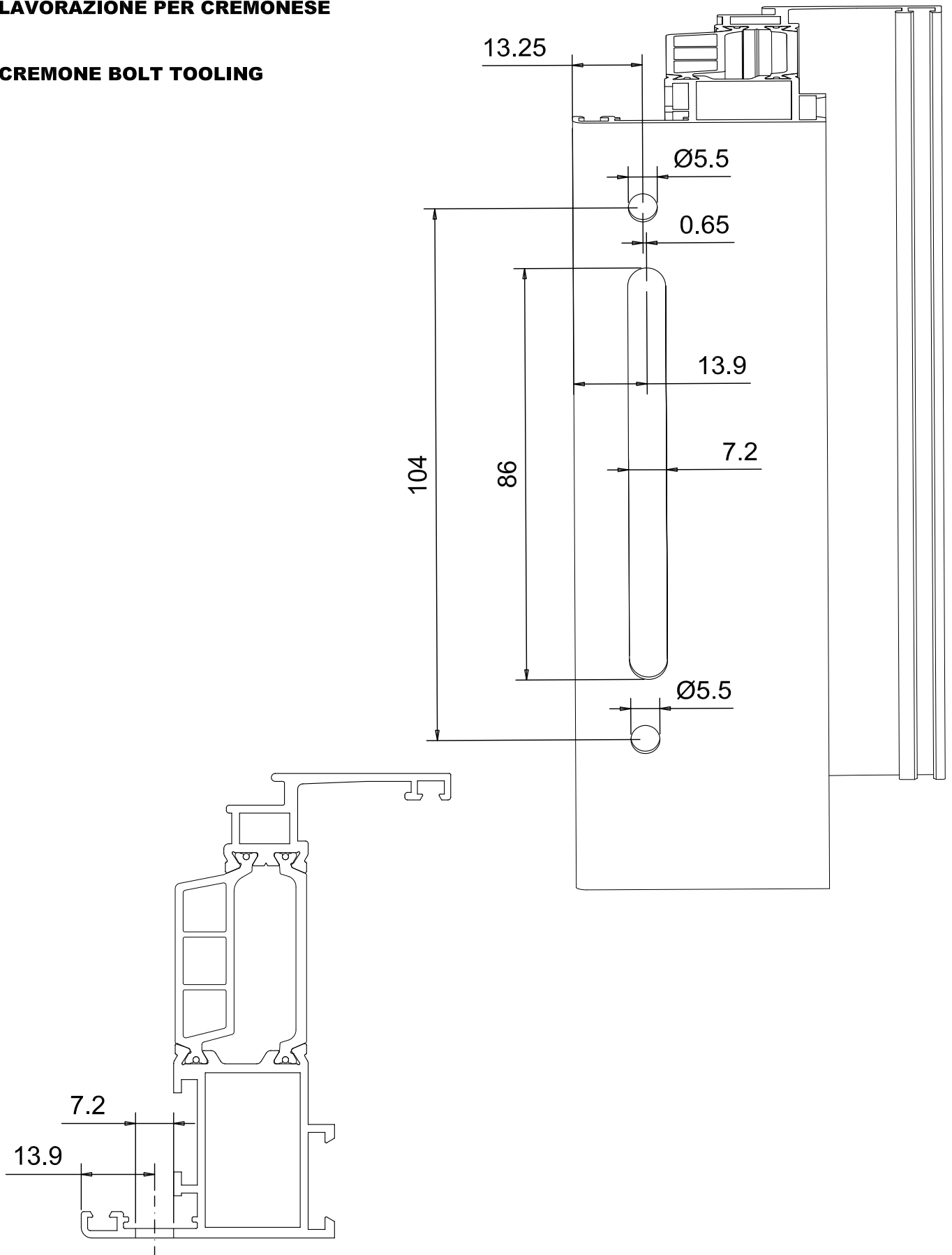

Lavorazioni - Tooling

**LAVORAZIONE PER SCARICO ACQUA
E VENTILAZIONE VETRI**

**WATER DRAINAGE AND
GLASS VENTILATION
TOOLING**

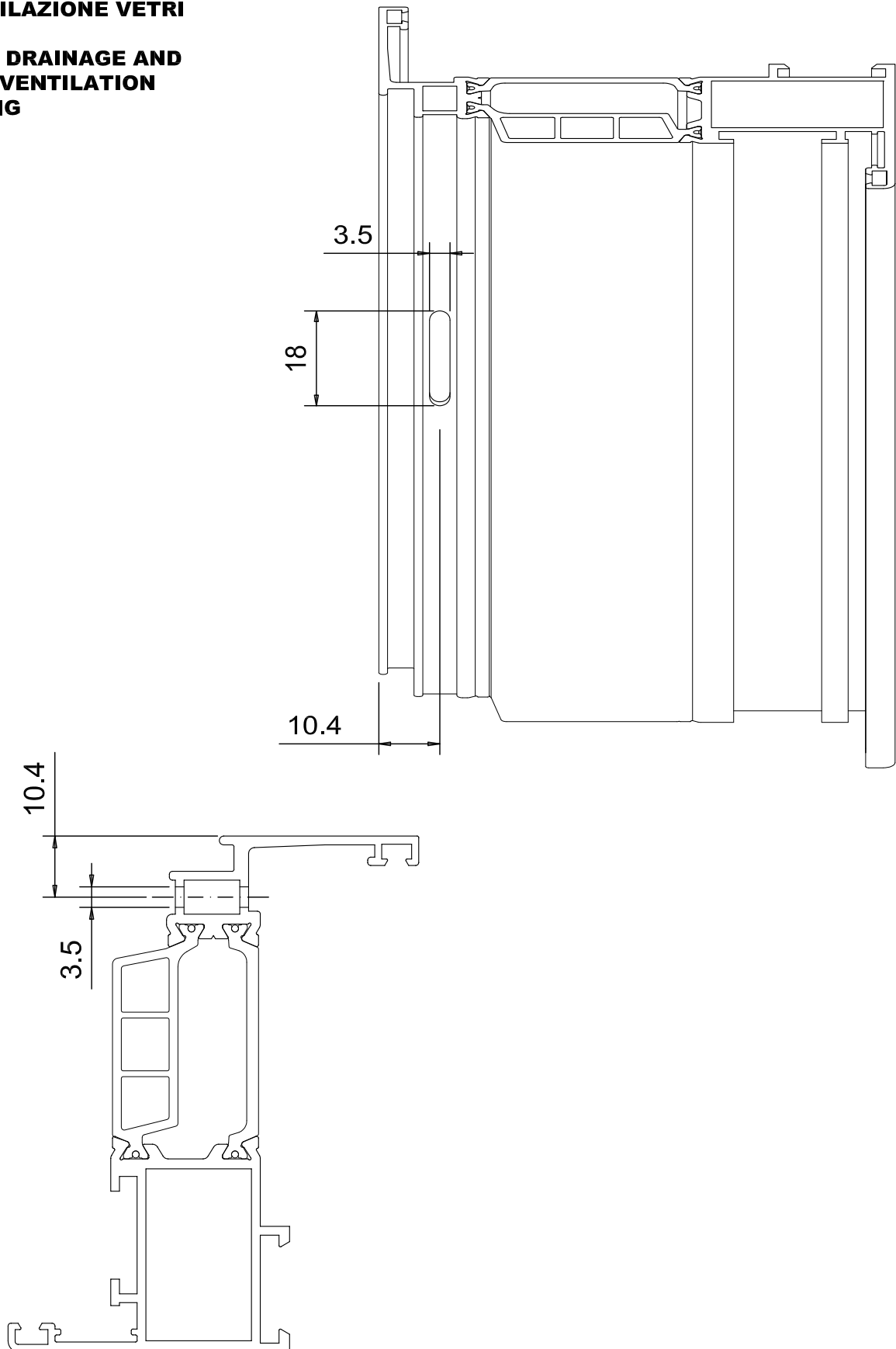

Lavorazioni - Tooling

LAVORAZIONE PER SCARICO ACQUA

WATER DRAINAGE TOOLING

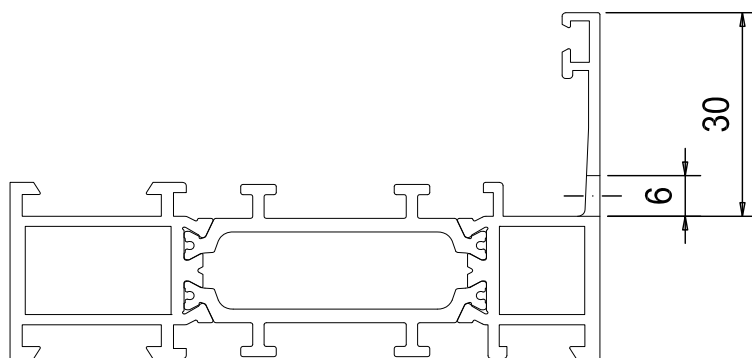
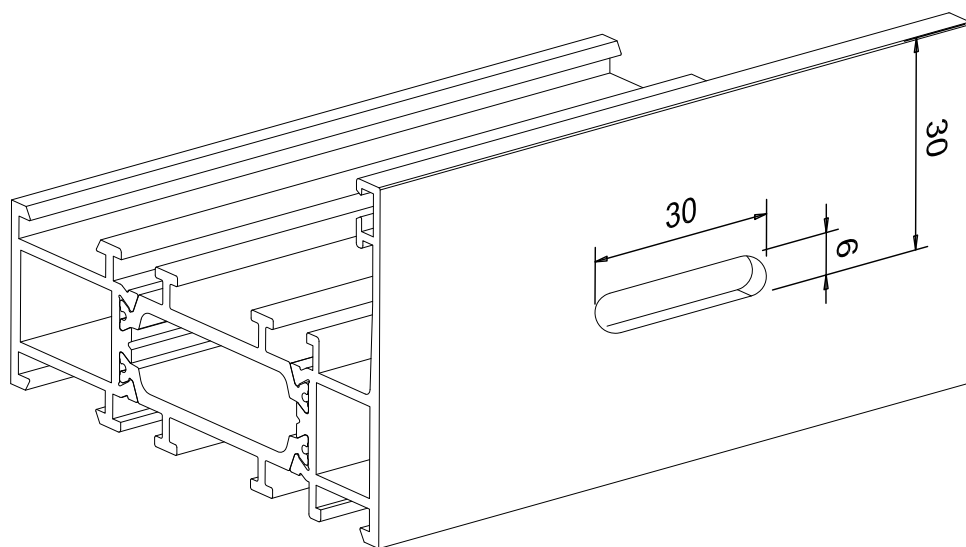

Lavorazioni - Tooling

**LAVORAZIONE PER
PASSAGGIO ASTA**

**REMOVAL FOR ROD
PASSAGE
TOOLING**

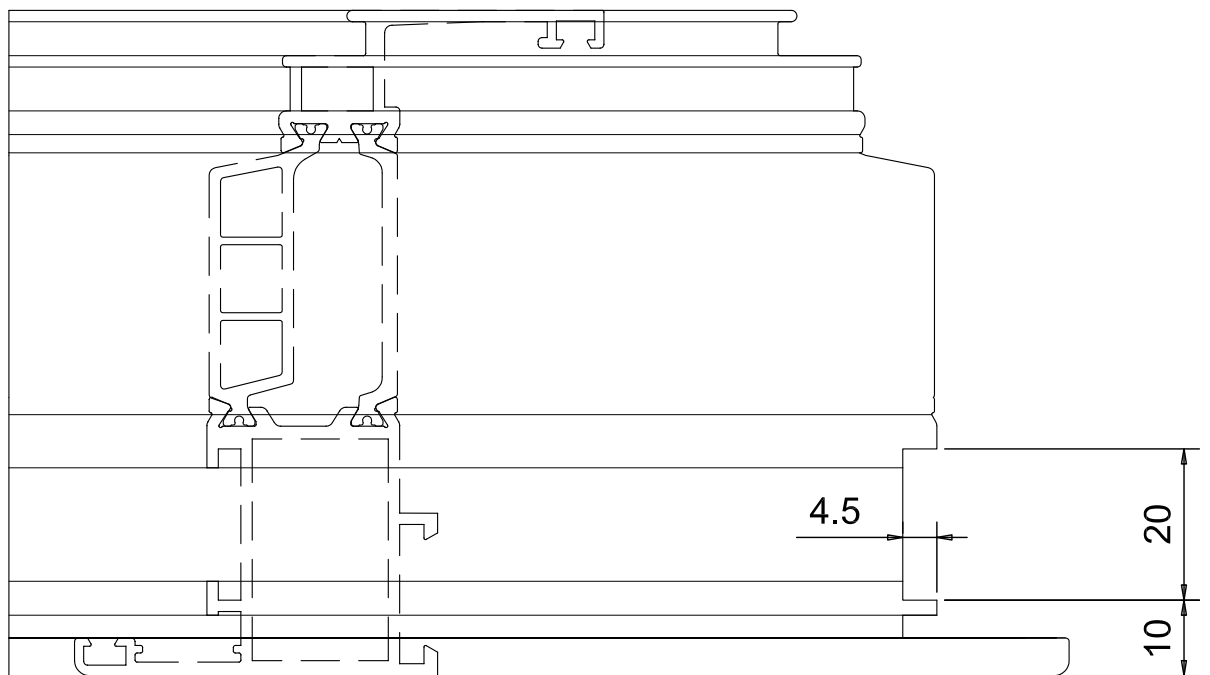
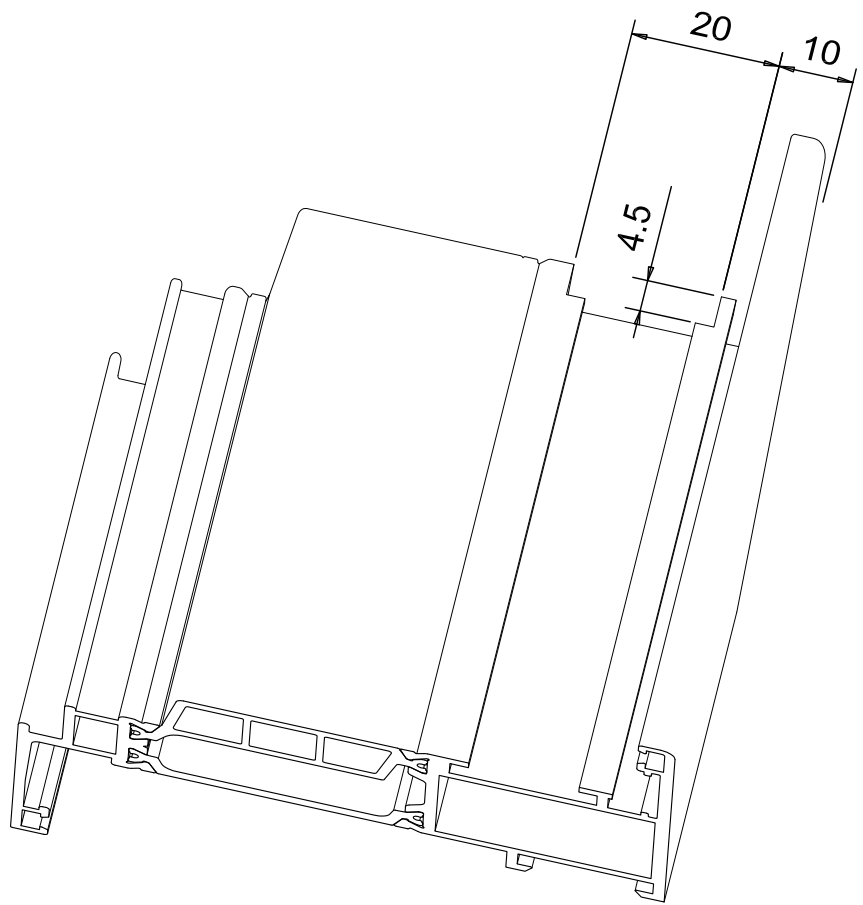

Lavorazioni - Tooling

**LAVORAZIONE TRAVERSI
PER TELAI FISSI**

**TRANSOM TOOLING
FOR FIXED FRAMES**

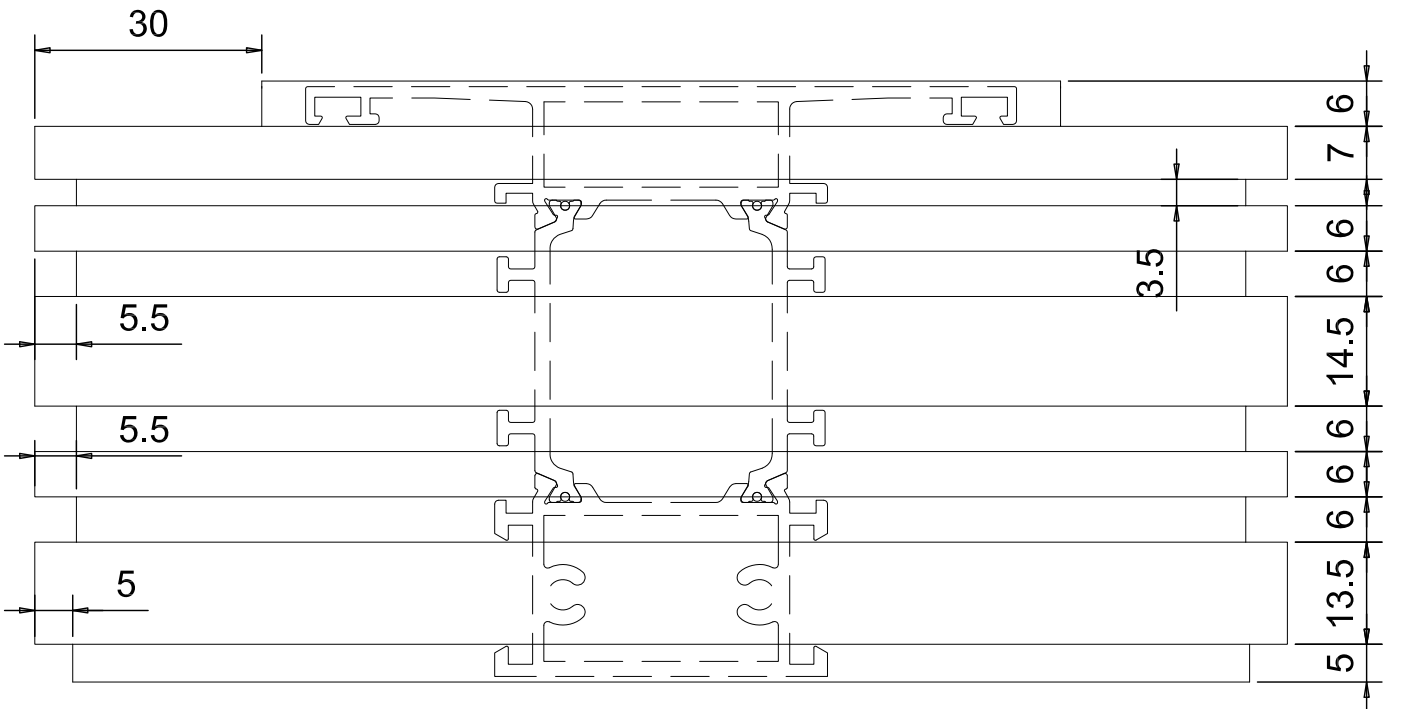
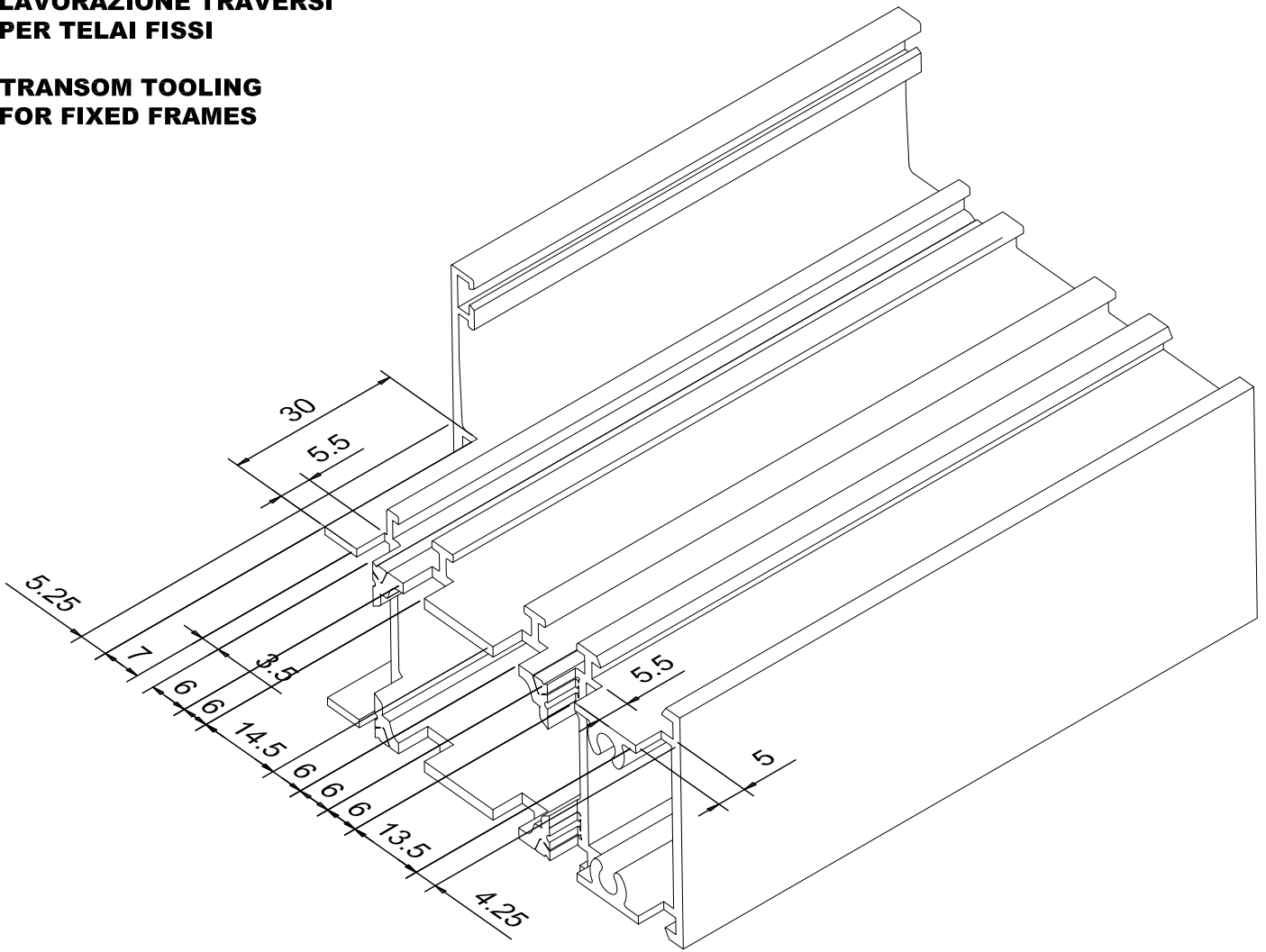

Lavorazioni - Tooling

**LAVORAZIONE TRAVERSI
PER ANTE SAGOMATE / STONDATE**

**TRANSOM TOOLING
FOR SHAPED / ROUNDED WINGS**

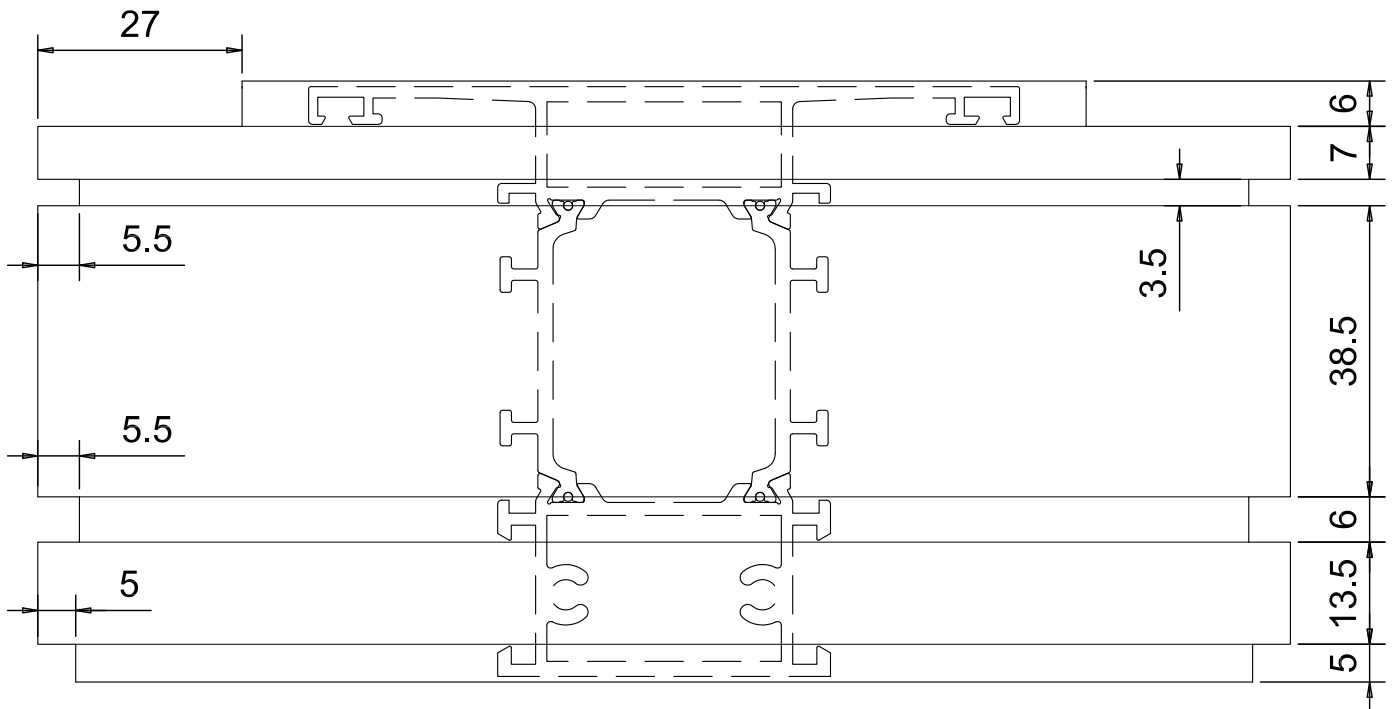
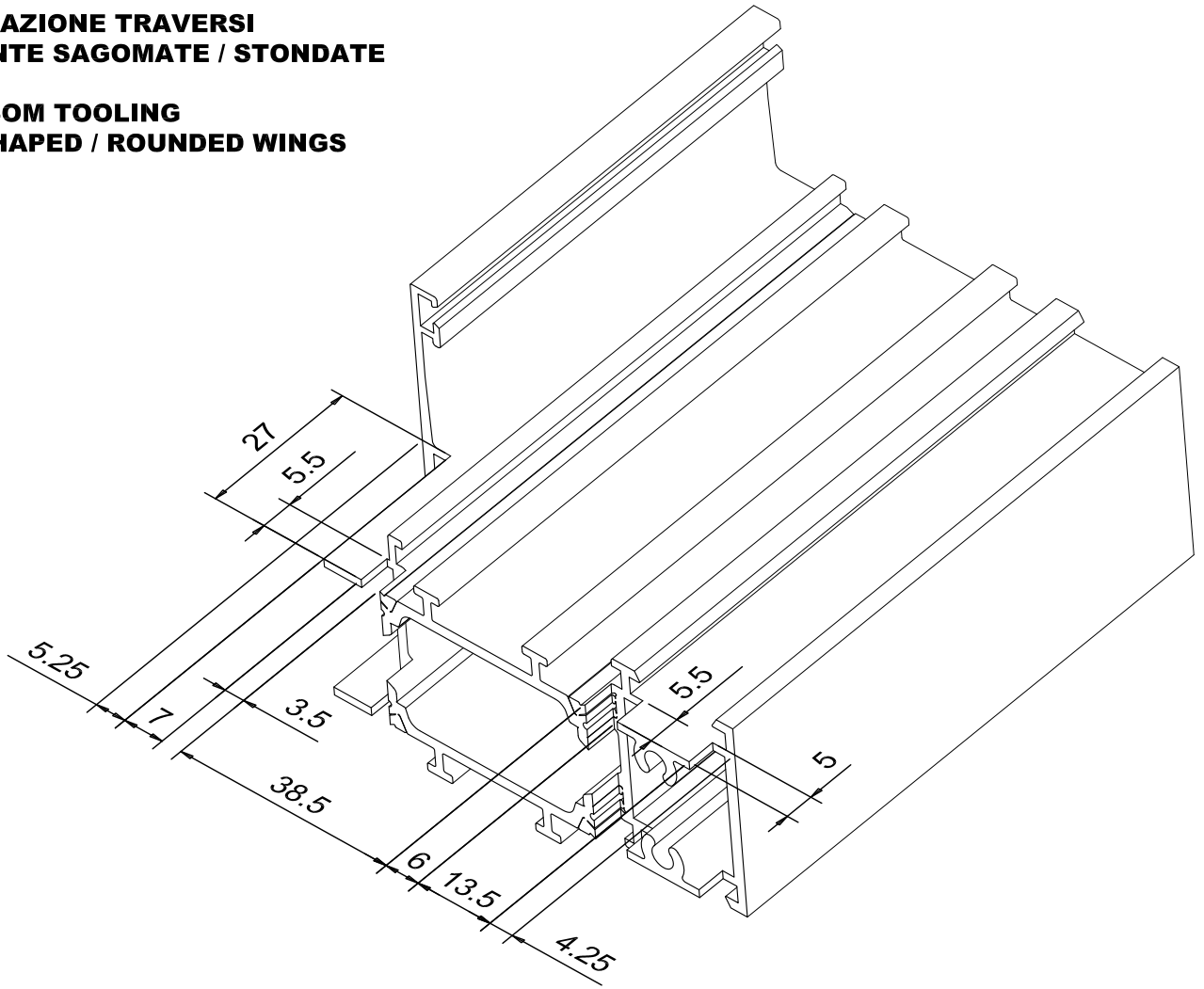

Lavorazioni - Tooling

**LAVORAZIONE TRAVERSI
PER ANTE COMPLANARI**

**TRANSOM TOOLING
FOR COPLANAR WINGS**

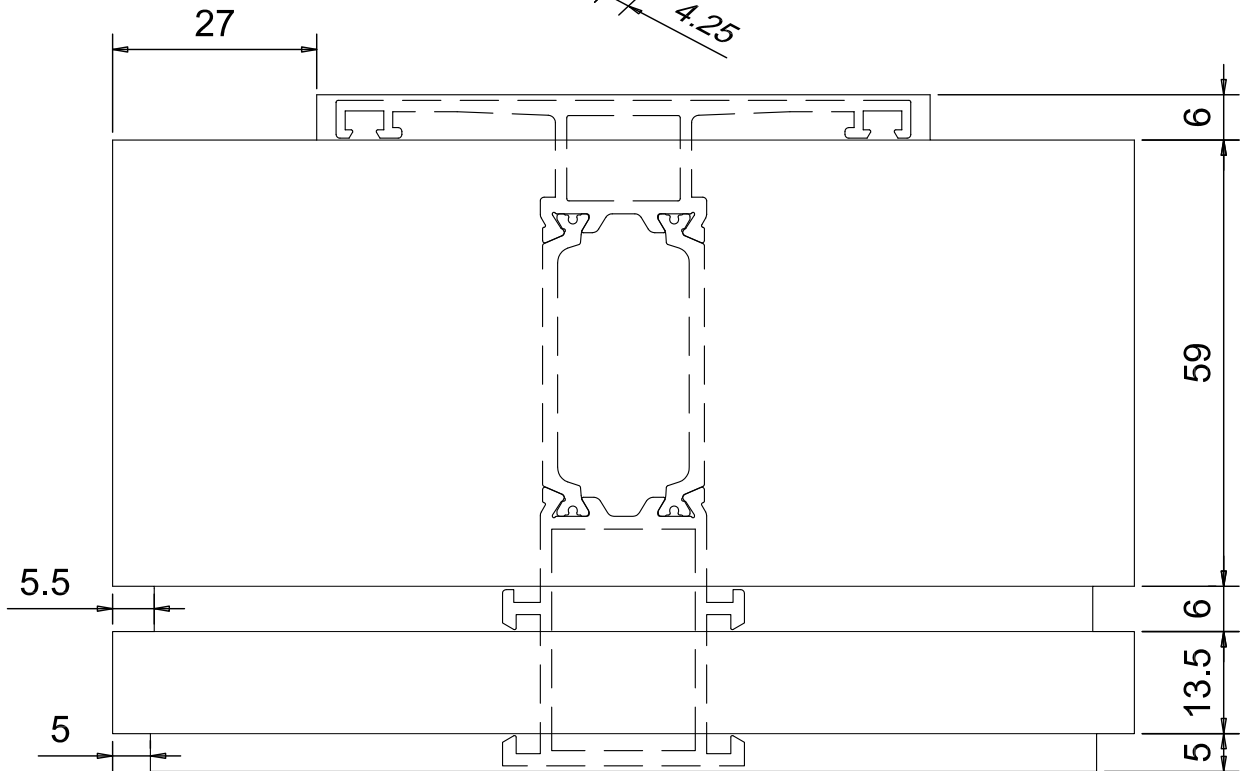
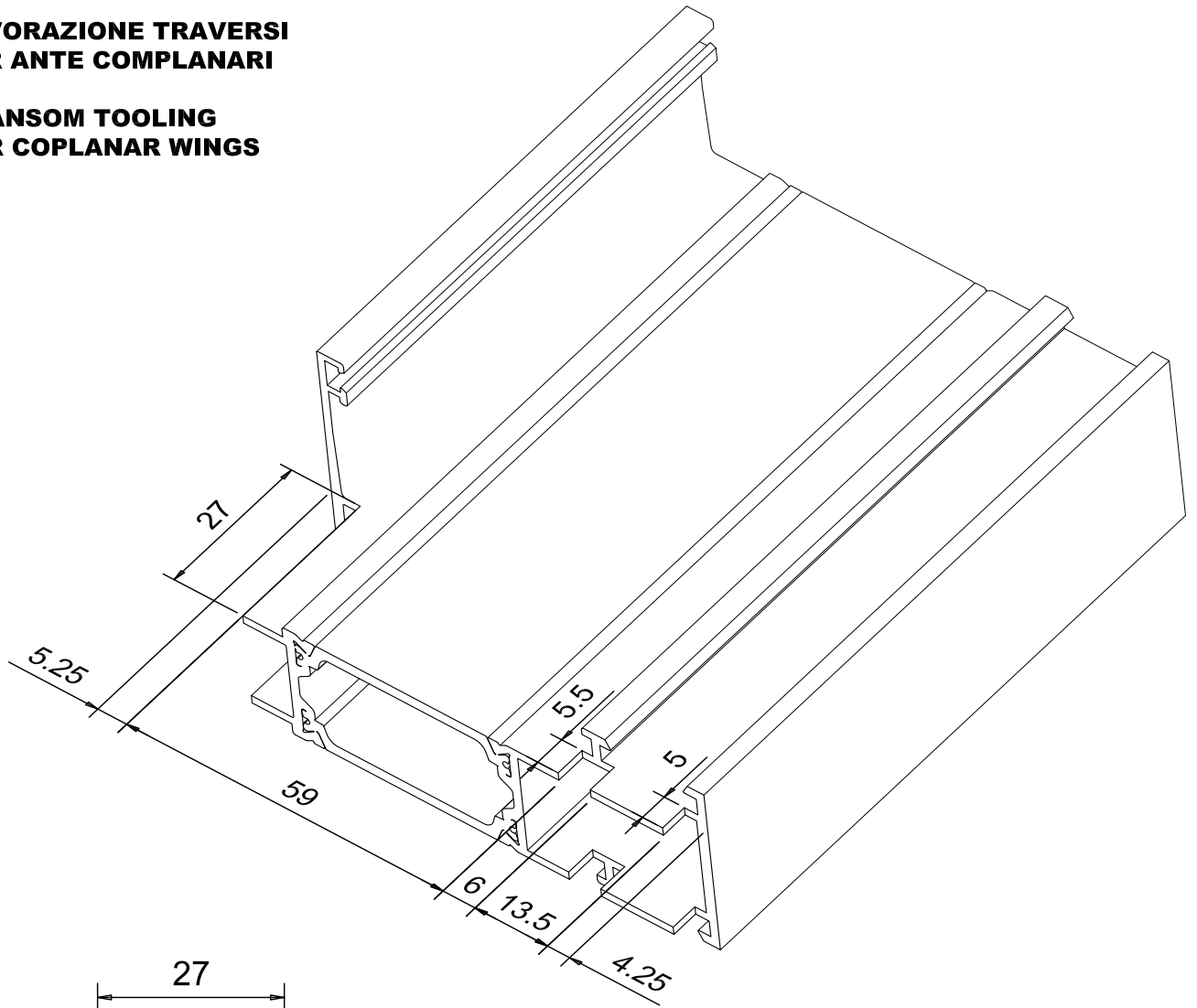

Lavorazioni - Tooling

**LAVORAZIONE TRAVERSI
PER CAVALLOTTI**

**TRANSOM TOOLING
FOR T-JOINT**

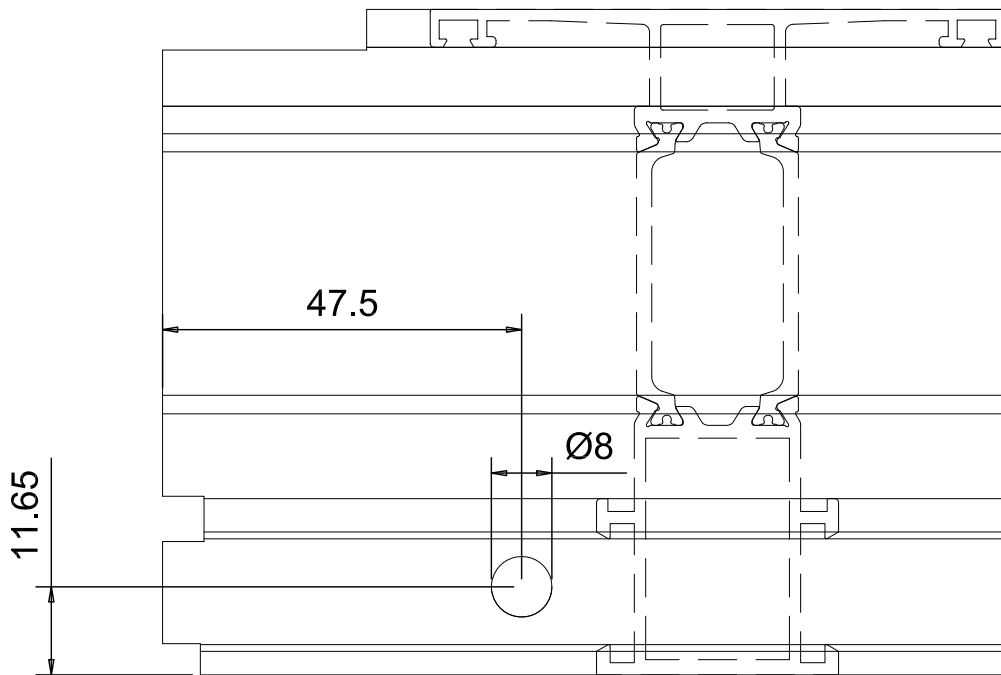
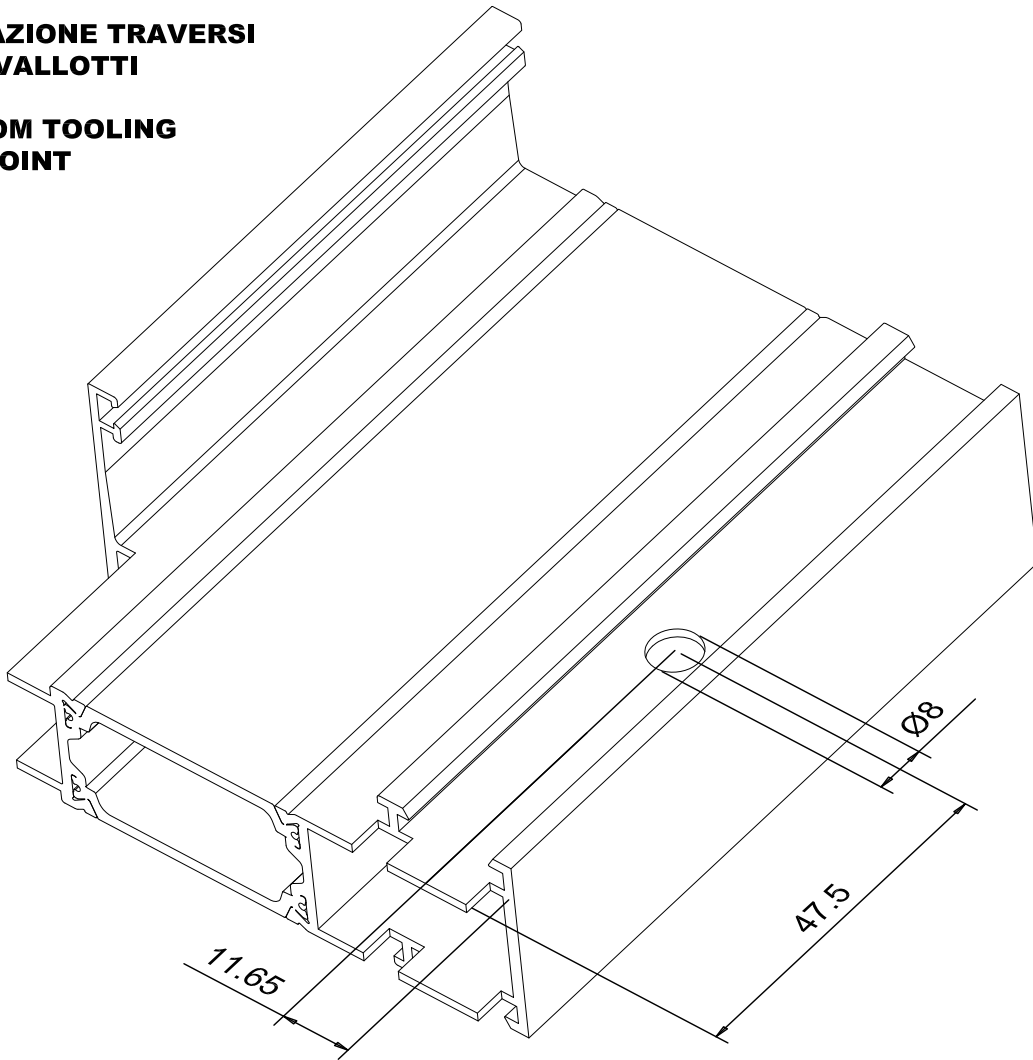

Lavorazioni - Tooling

**LAVORAZIONE TRAVERSI
PER CAVALLOTTI**

**TRANSOM TOOLING
FOR T-JOINT**

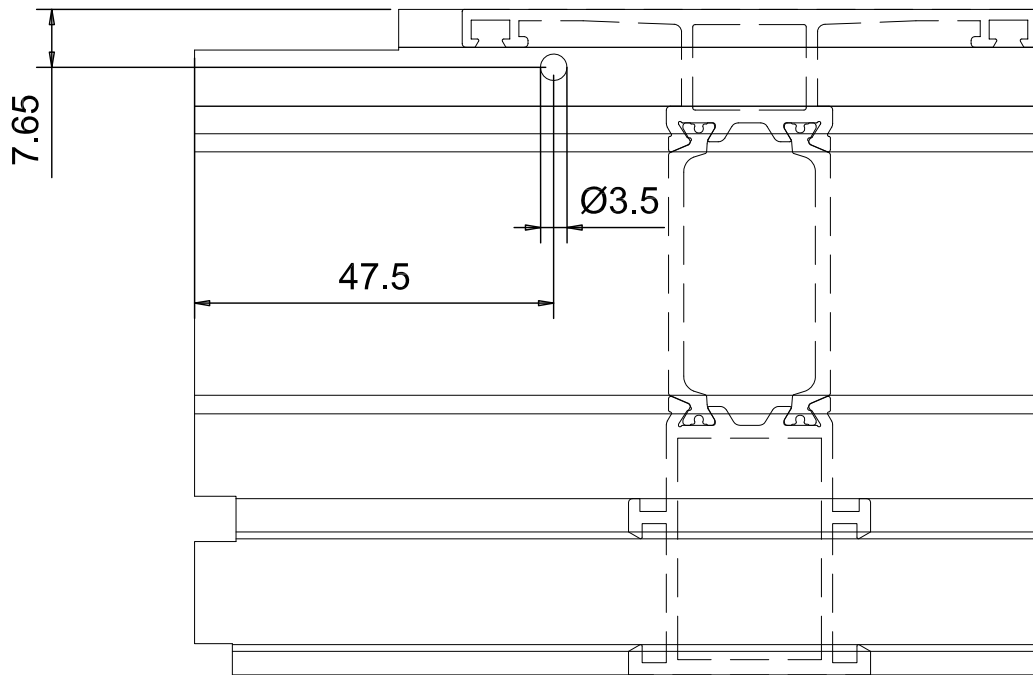
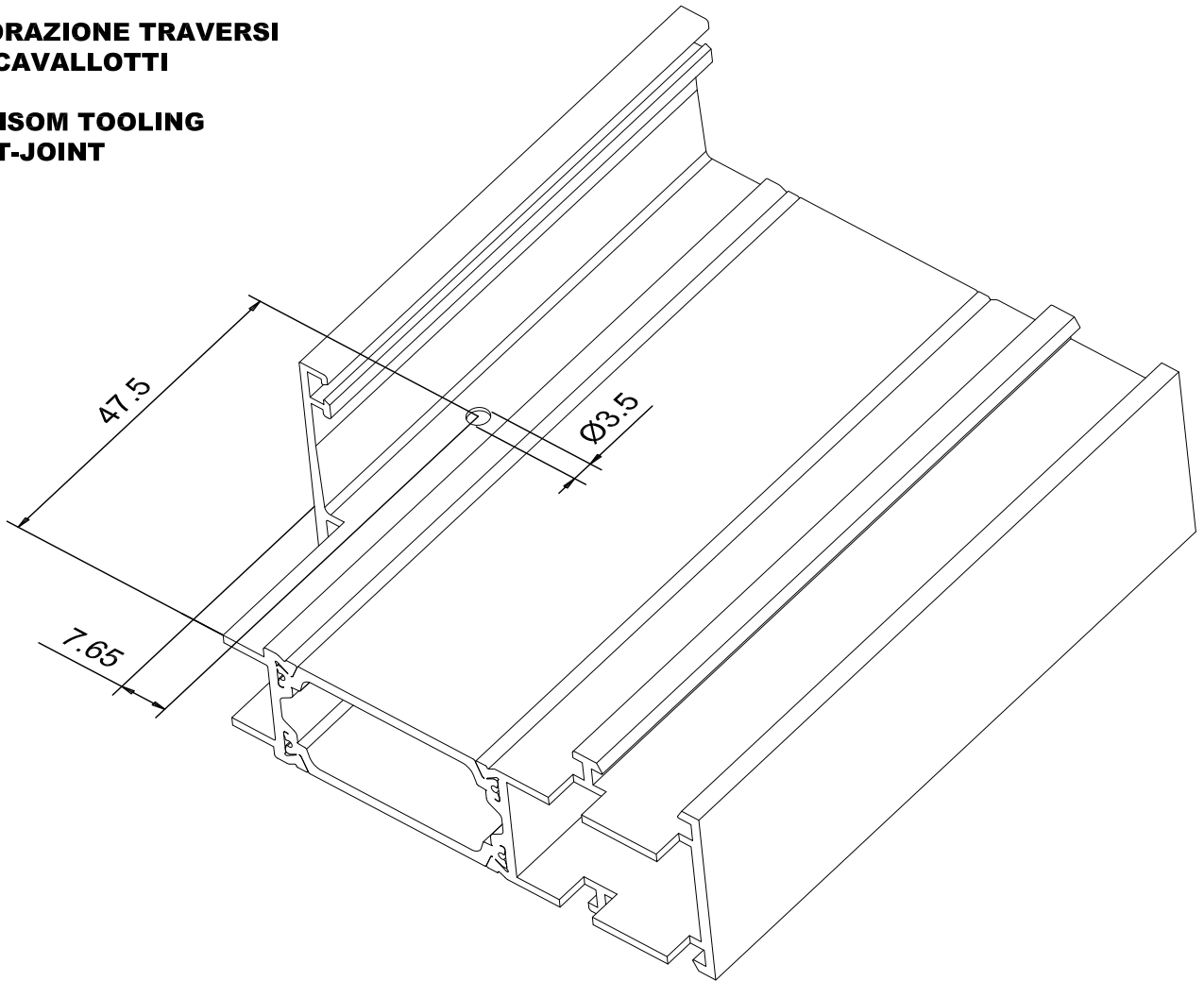

Lavorazioni - Tooling

**LAVORAZIONE PER
RAPID BLOCK Z/P**

**TOOLING FOR
RAPID BLOCK Z/P**

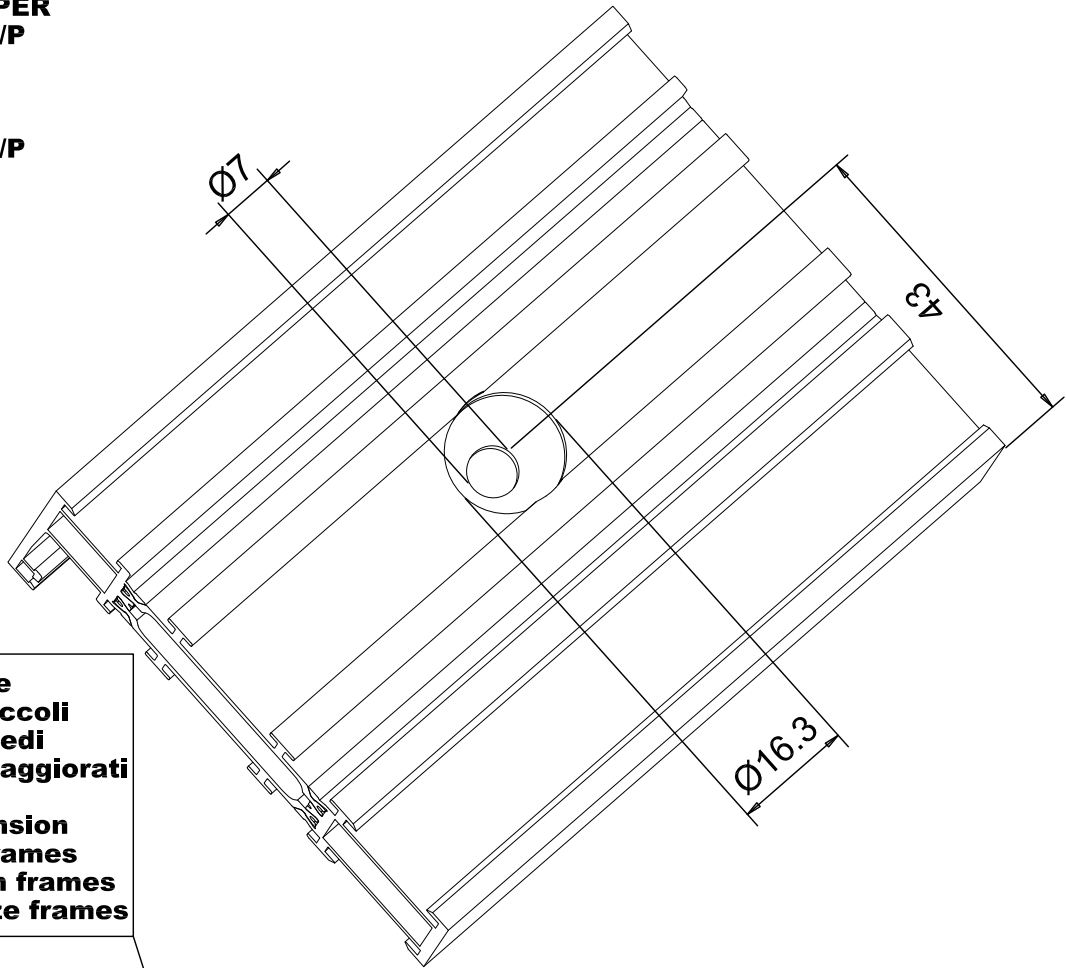

*** quota variabile**
13,6 per telai piccoli
23,4 per telai medi
31,3 per telai maggiorati

*** variable dimension**
13,6 for small frames
23,4 for medium frames
31,3 per oversize frames

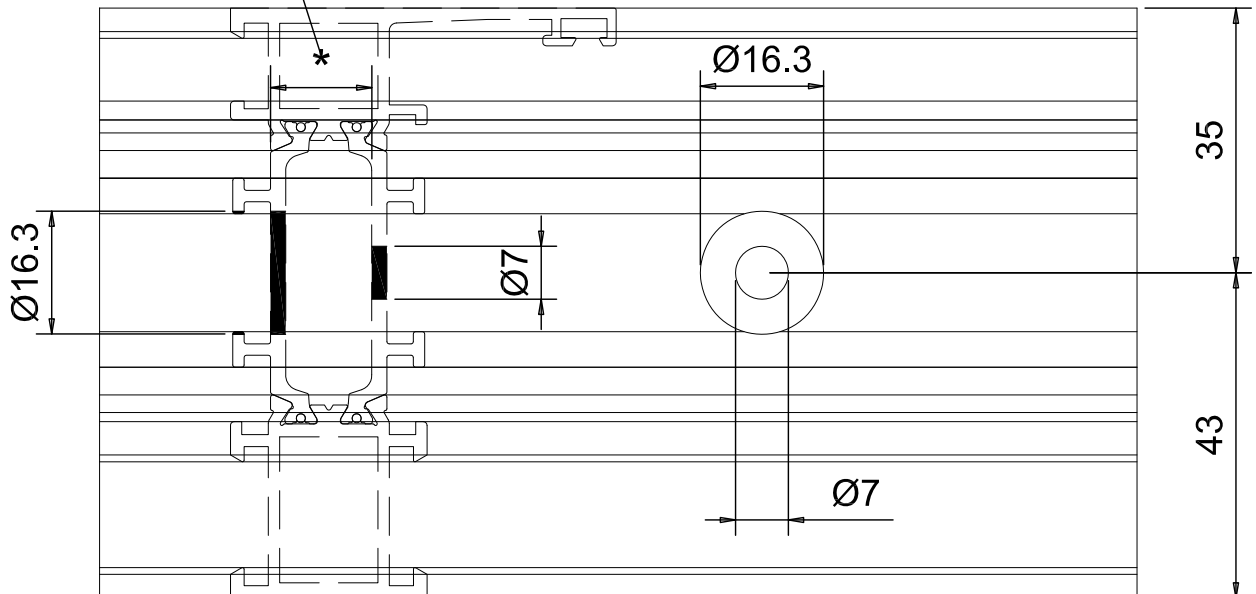

**UTILIZZARE PUNTA A DUE DIAMETRI
PER RAPID BLOCK Z/P
ART. 104-RP019**

**USE TWO DIAMETERS BIR
FOR RAPID BLOCK Z/P
ITEM 104-RP019**

Lavorazioni - Tooling

**LAVORAZIONE PER
FISSAGGIO SOGLIA RIDOTTA**

**TOOLING FOR
SMALL THRESHOLD FIXING**

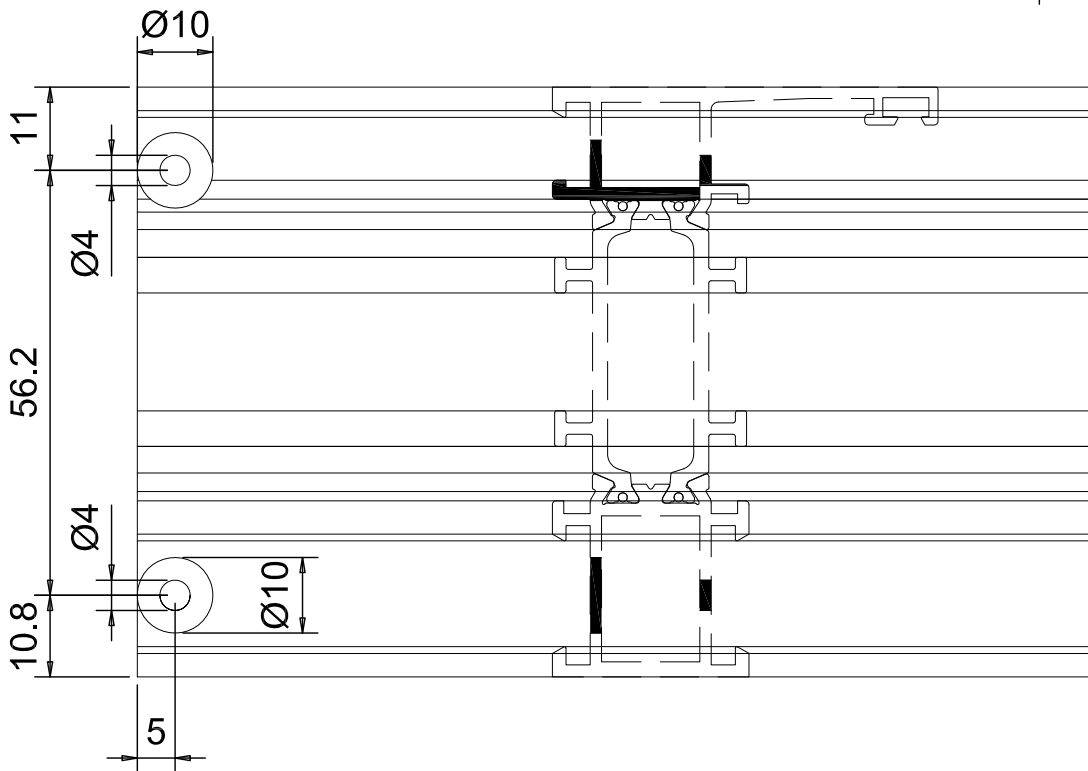
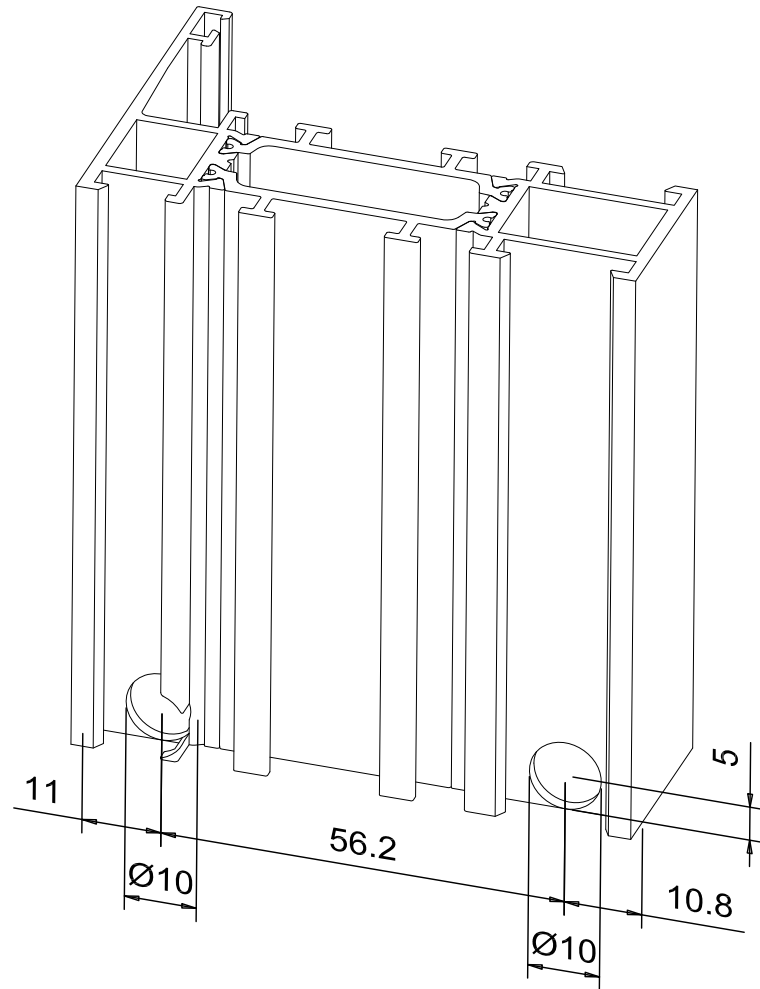

Squadrette telai fissi - Corner Joint for Fixed Frames

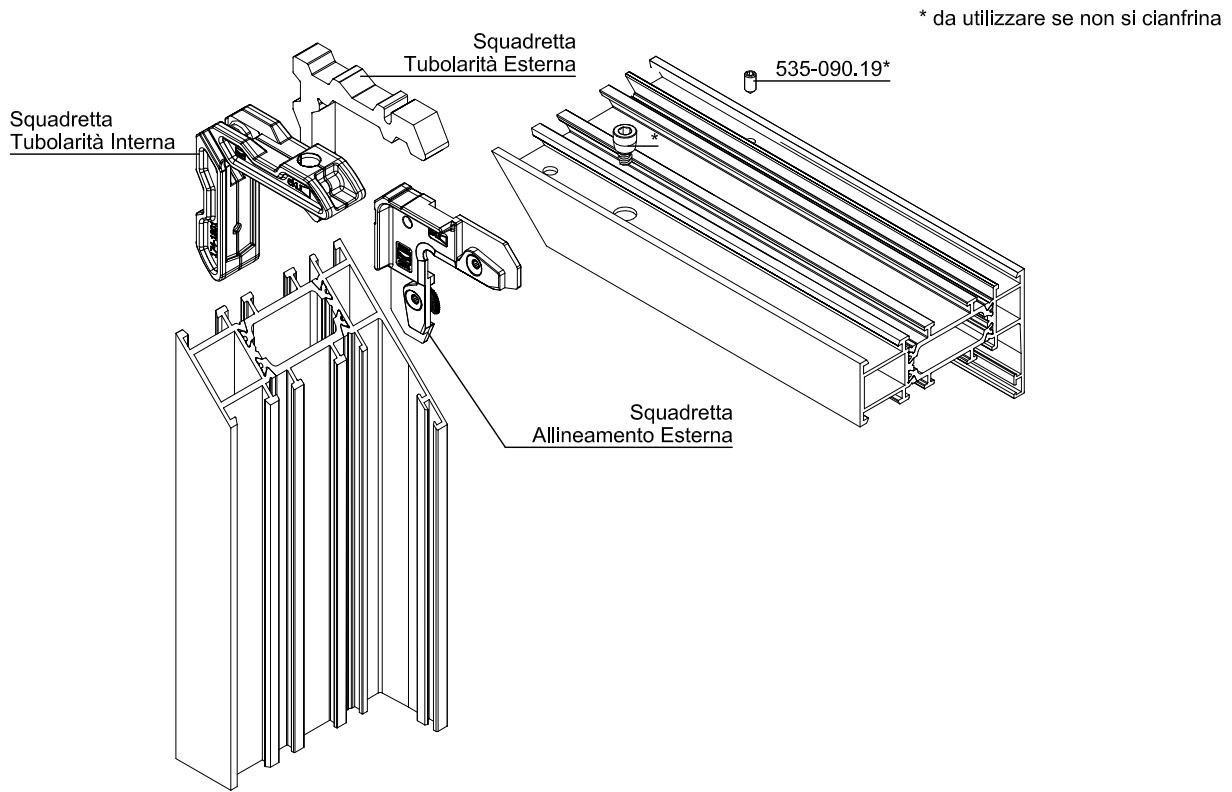

Codice Profilo	Codice Squadretta Tubolarità Interna	Codice Squadretta Tubolarità Esterna	Codice Squadretta Allineamento Esterna	Codice Squadretta Allineamento Interna
TT78-01	174-1801	153-0057	174-1591	
TT78-02	174-1801	153-0057	174-1591	
TT78-03	174-1801	153-0057	174-1591	
TT78-04	174-1803	153-0059	174-1591	
TT78-05	174-1803	153-0059	174-1591	
TT78-06	174-1803	153-0059	174-1591	
TT78-07	174-1805	153-0061	174-1591	
TT78-08	174-1805	153-0061	174-1591	
TT78-09	174-1805	153-0061	174-1591	
TT78-40	174-1801	153-0057	174-1591	
TT78-46	174-1801	153-0057	174-1591	
TT78-51	174-1801	153-0057	174-1591	153-040.4
TT78-52	174-1803	153-0059	174-1591	153-040.4
TT78-53	174-1805	153-0061	174-1591	153-040.4

Squadrette ante - Corner Joint for Wings

* da utilizzare se non si cianfrina

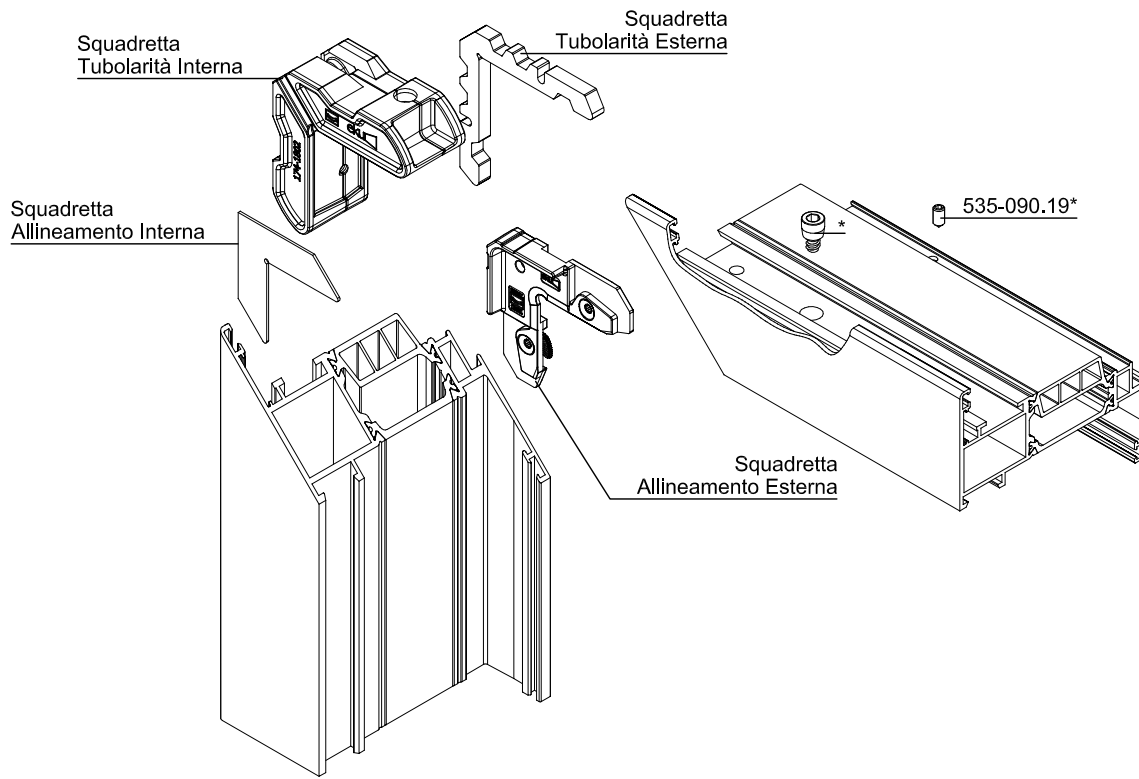

Codice Profilo	Codice Squadretta Tubolarità Interna	Codice Squadretta Tubolarità Esterna	Codice Squadretta Allineamento Esterna	Codice Squadretta Allineamento Interna
TT78-10	174-1802	153-0058	174-1591	153-040.4
TT78-11	174-1804	153-0060	174-1591	153-040.4
TT78-12	174-1806	153-0062	174-1591	153-040.4
TT78-16	174-1802	153-0058	174-1591	153-040.4
TT78-17	174-1804	153-0060	174-1591	153-040.4
TT78-18	174-1806	153-0062	174-1591	153-040.4
TT78-22	174-1802	153-0060	174-1591	153-040.4
TT78-37	153-0060	174-1804	174-1591 + 153-040.4	—
TT78-38	153-0062	174-1806	174-1591 + 153-040.4	—

Cavallotti per Fissi - "T" Joint for Fixed Frames

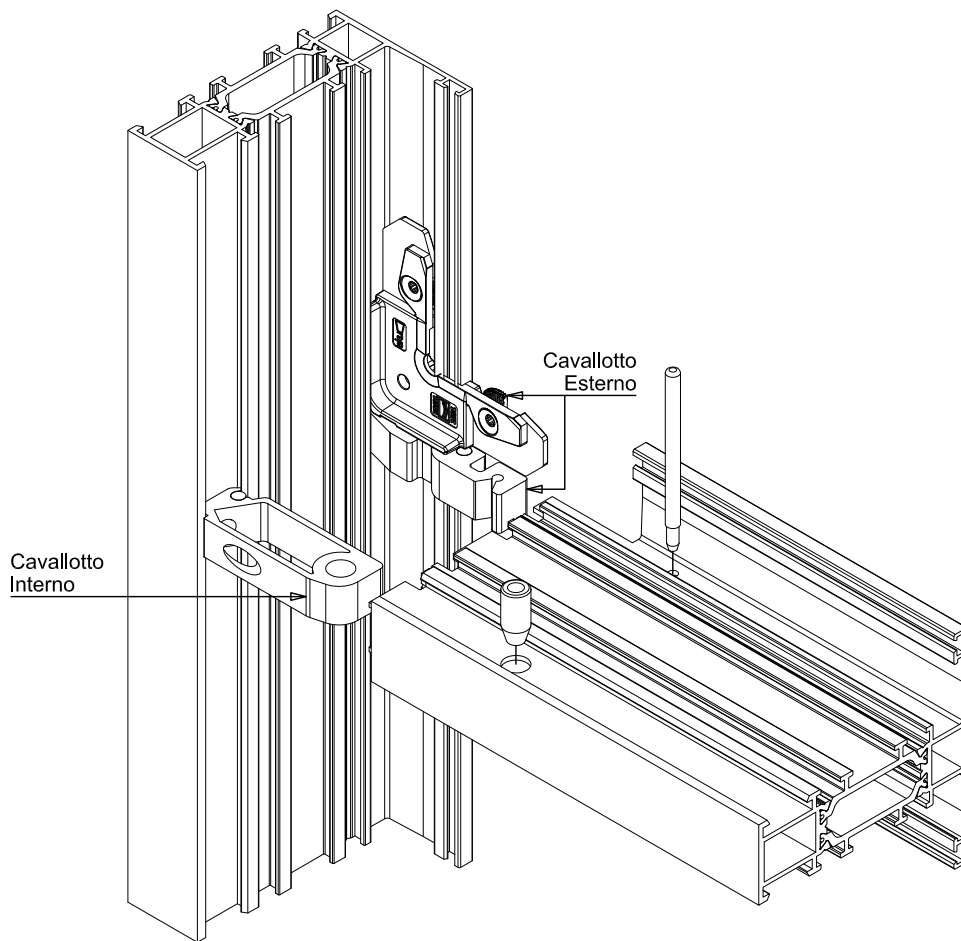

Codice Profilo Trasverso	Codice Cavalotto Interno	Codice Cavalotto Esterno	Codice Cavalotto Esterno + Spina	Guarnizione Cavallotti Interni/Esterni
TT78-03	EA-0133	174-1591	EA-0137 + EA-0143	EG-0052
TT78-06	EA-0134	174-1591	EA-0138 + EA-0143	EG-0052
TT78-09	EA-0135	174-1591	EA-0139 + EA-0143	EG-0052
TT78-30	EA-0135	174-1591	EA-0139 + EA-0143	EG-0052
TT78-47	EA-0135	174-1591	EA-0139 + EA-0143	EG-0052

Cavallotti per Ante Sagomate/Stondate - "T" Joint for Shaped/Rounded Wings

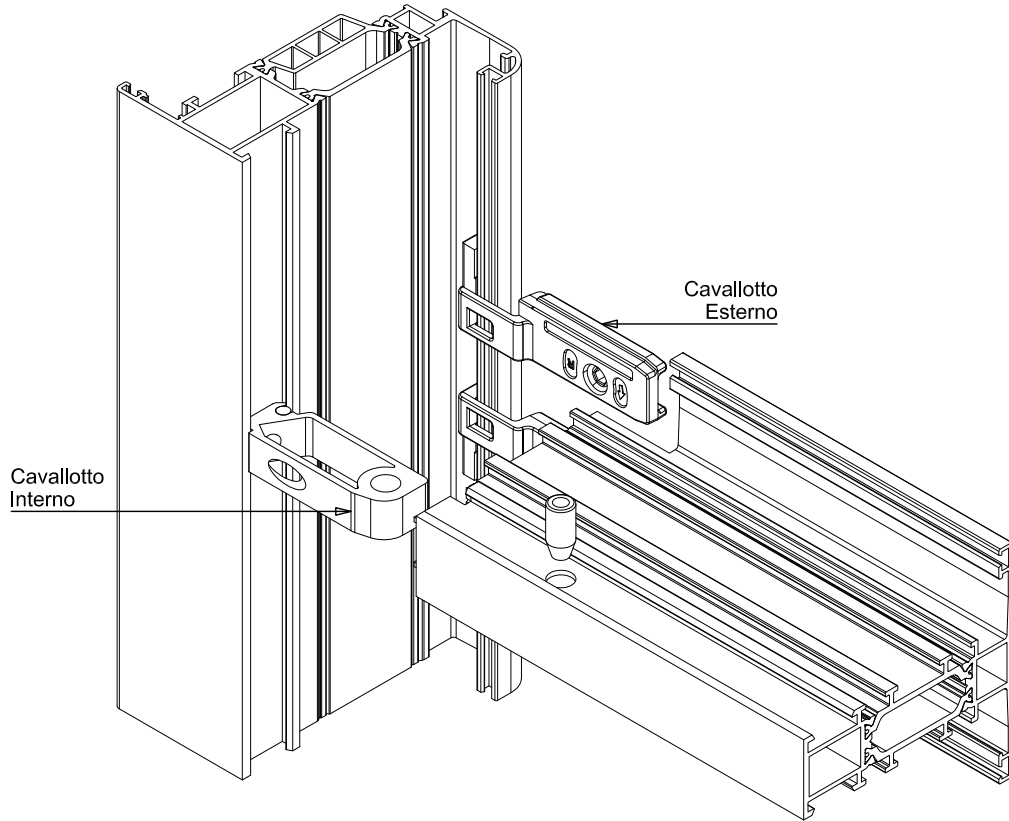

Codice Profilo Trasverso	Codice Cavallotto Interno	Codice Cavallotto Esterno		
TT78-03	EA-0133	EA-0032		
TT78-06	EA-0134	EA-0032		
TT78-09	EA-0135	EA-0032		
TT78-30	EA-0135	EA-0032		
TT78-47	EA-0135	EA-0032		

Cavallotti per Ante Complanari - "T" Joint for Complanar Wings

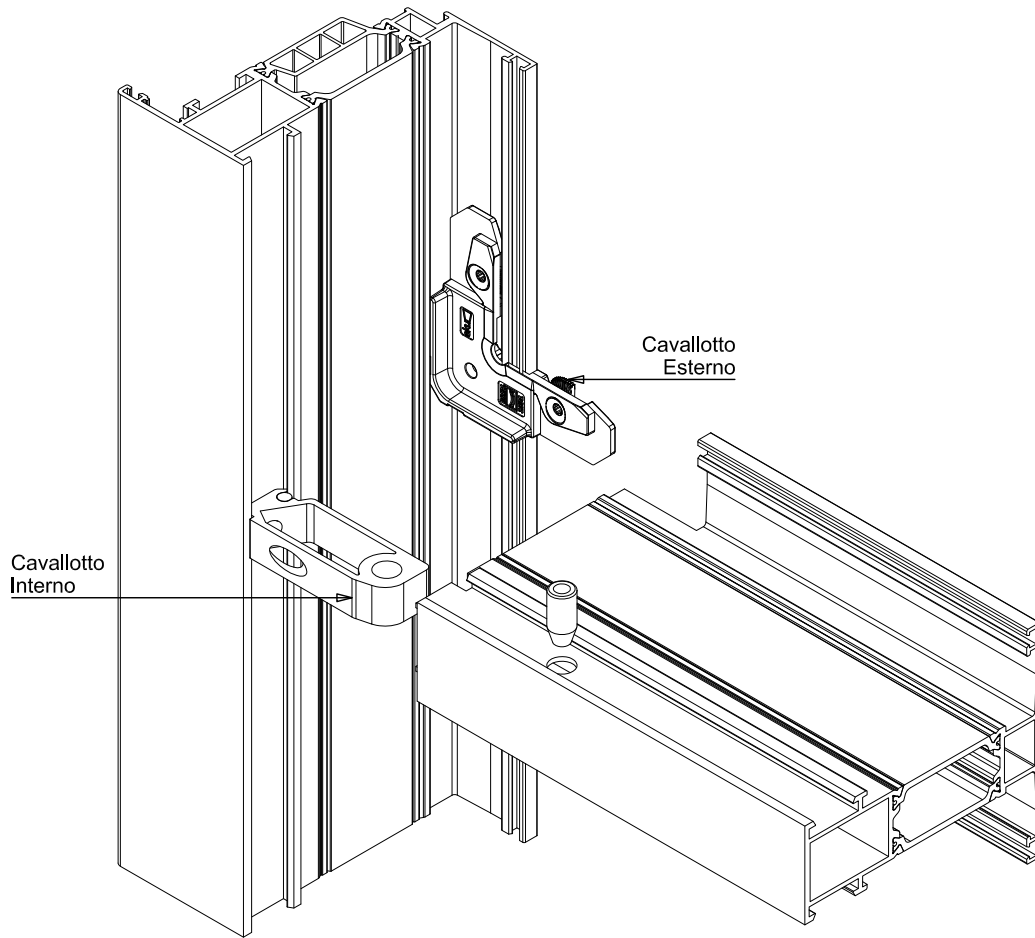

Codice Profilo Trasverso	Codice Cavallotto Interno	Codice Cavallotto Esterno		
TT78-33	EA-0136	174-1591		
TT78-34	EA-0135	174-1591		
TT78-50	EA-0135	174-1591		

Lavorazioni - Tooling

**LAVORAZIONE FORO DI TESTA
E CENTRALE ASTINA**

**TOOLING FOR
TOP AND CENTRAL
HOLE OF ROD**

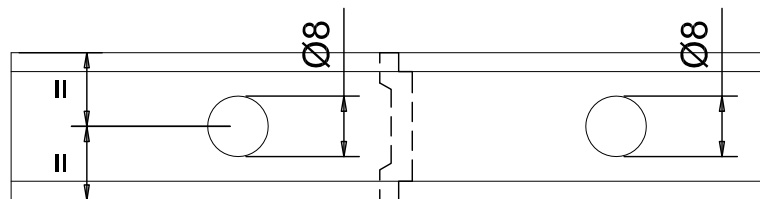
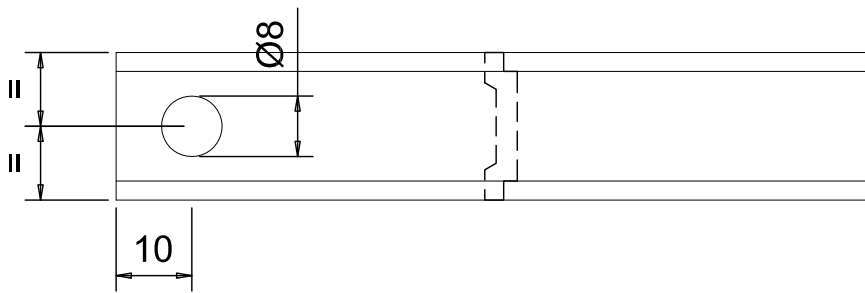
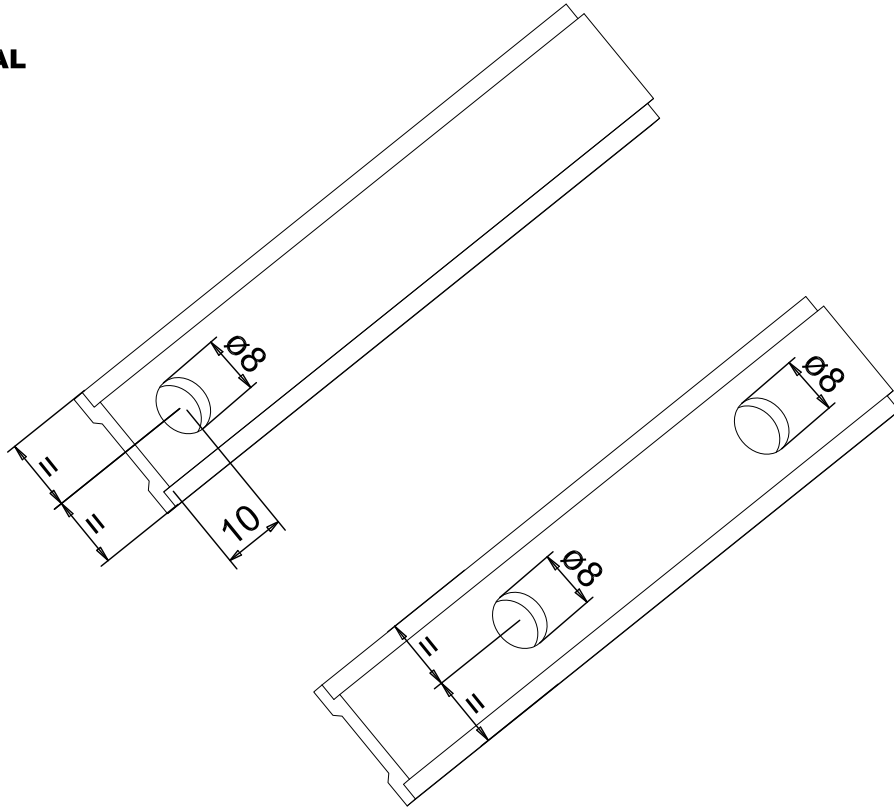

Collegamenti alla muratura - *Links to the wall*

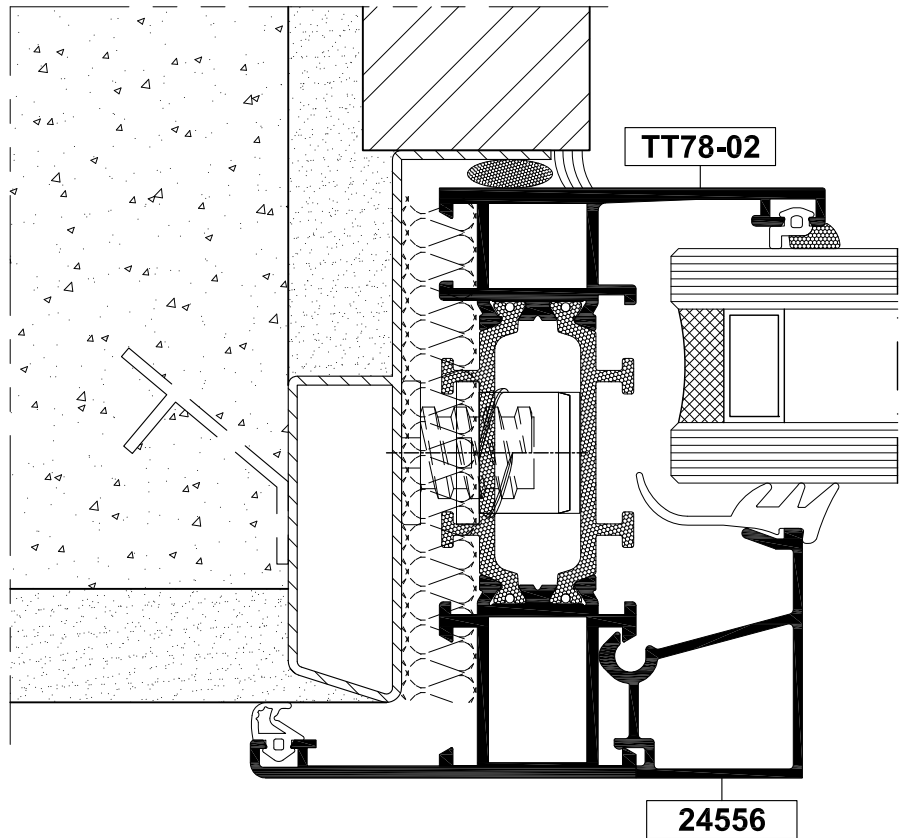
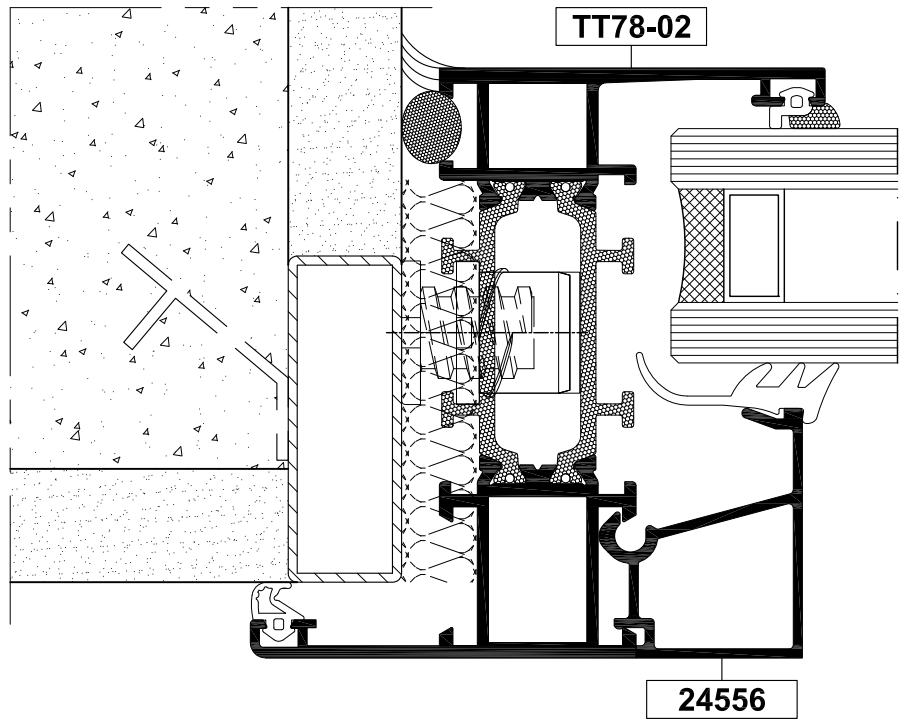
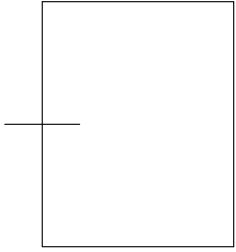

Collegamenti alla muratura - *Links to the wall*

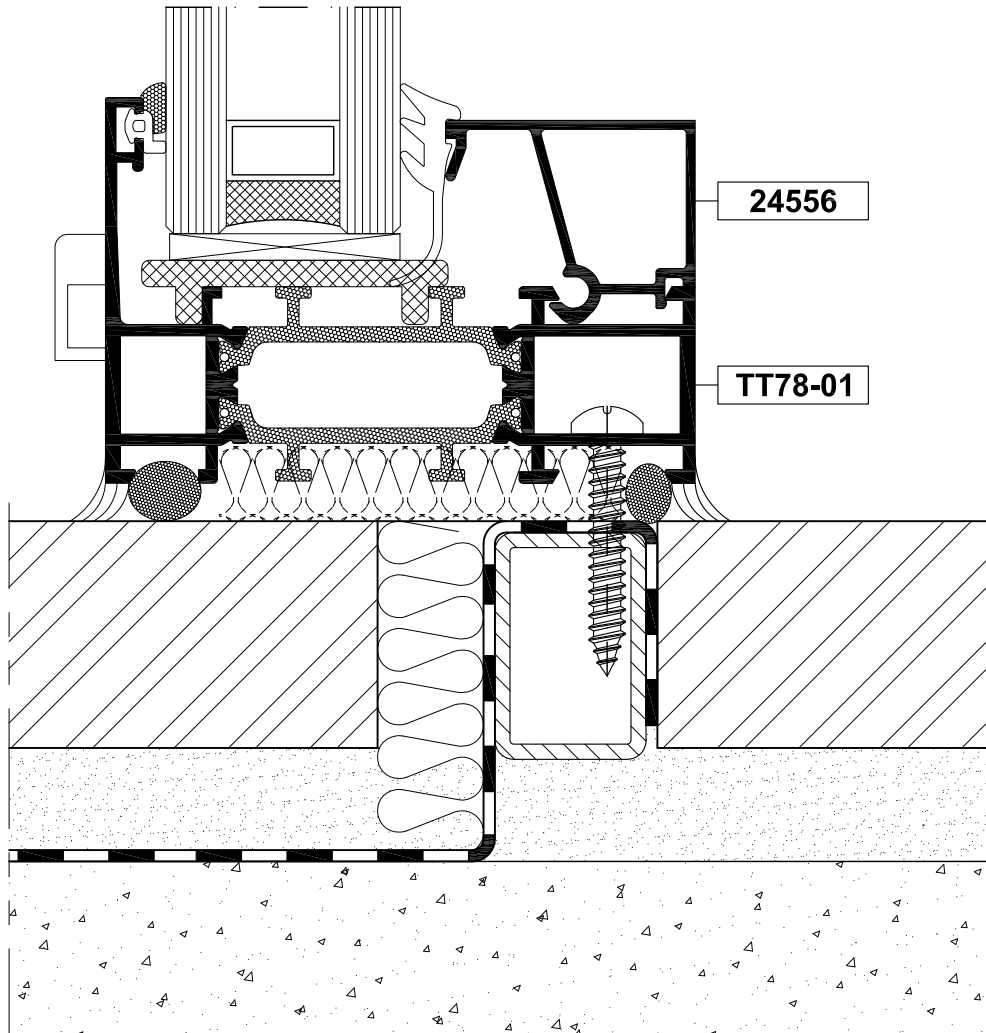
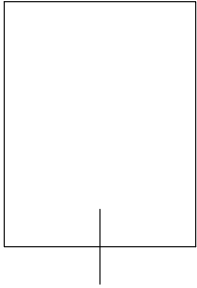

Collegamenti alla muratura - *Links to the wall*

